

RADIO & TELEVISION

FORMERLY
SHORT WAVE & TELEVISION

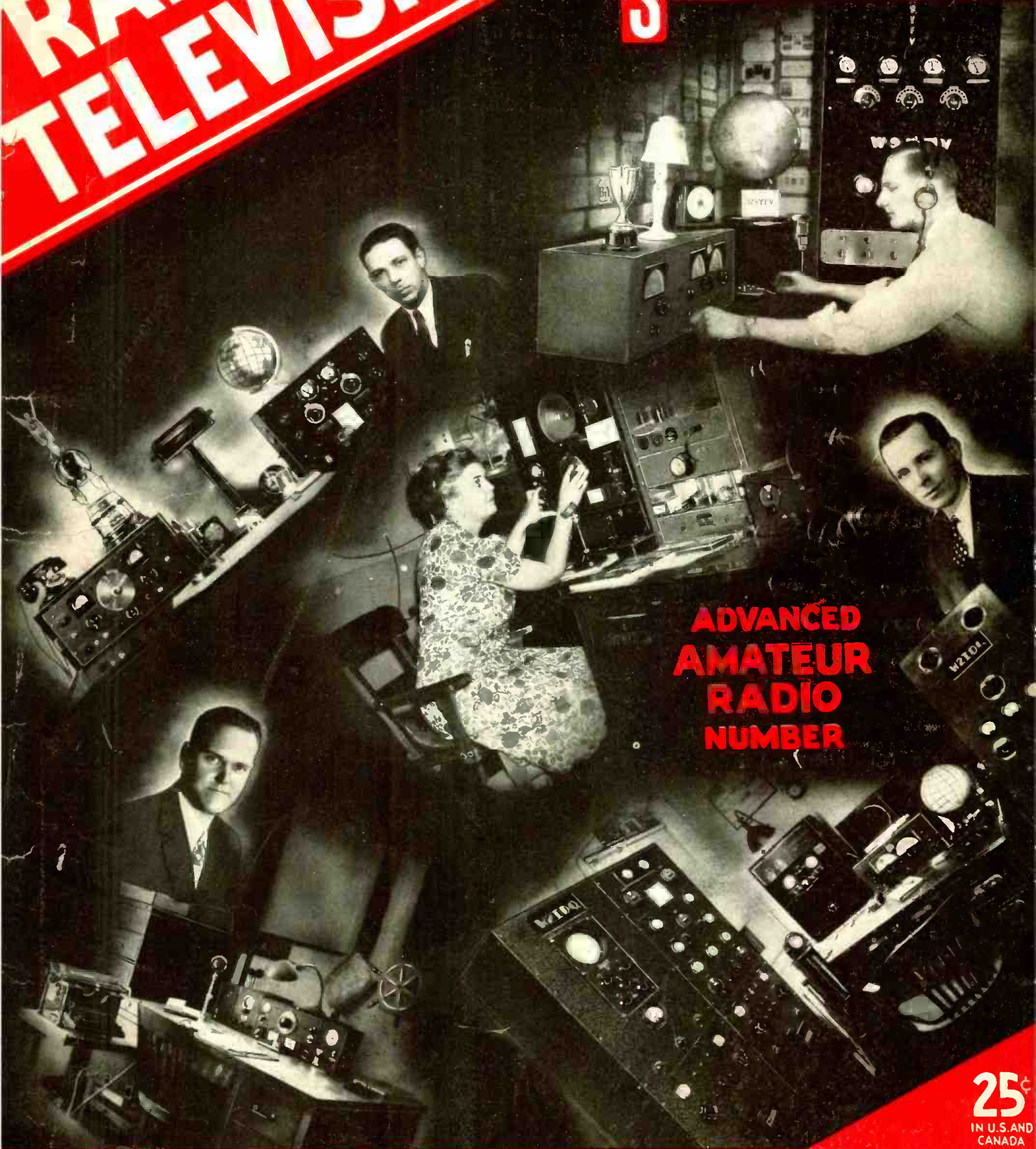

**ADVANCED
AMATEUR
RADIO
NUMBER**

**HUGO
GERNSBACK**
EDITOR

**RADIO EXPERIMENTING
AMATEUR RADIO**

25¢
IN U.S. AND
CANADA

**NOV.
1938**

You can't lose! A money-back guarantee protects you!

THE RADIO AMATEUR COURSE REPRESENTS THE GREATEST BOOK VALUE EVER OFFERED TO RADIO "FANS" FOR 50c

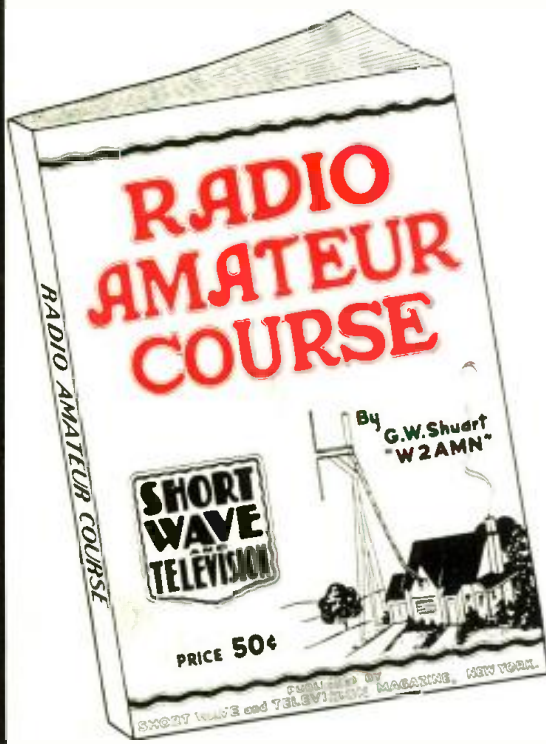

To convince you that there isn't a better book buy today the publishers of the RADIO AMATEUR COURSE make the sensational offer of a money-back guarantee on such a low-priced book. Stop in at any of the many dealers listed below and examine this volume. See for yourself if the RADIO AMATEUR COURSE isn't just the book you've always wanted.

**148 PAGES . . . 6 1/4 x 9 1/2 INCHES
OVER 150 DIAGRAMS AND PHOTOGRAPHS**

Printed on the finest quality paper—well illustrated attractive 4-color cover—complete with radio information you must have. It contains a step-by-step program for obtaining a short-wave radio education.

Written by George W. Shuart, W2AMN, foremost short-wave authority

ON SALE AT THE FOLLOWING DEALERS

- ARIZONA**
Sam's Cigar Store,
127 N. First Ave., Phoenix.
- CALIFORNIA**
Scott Wholesale Radio Co.,
314 E. Fourth Street, Long Beach.
Offenbach Electric Co., Ltd.,
1452 Market Street, San Francisco.
Zack Radio Supply Co.,
1426 Market Street, San Francisco.
- COLORADO**
Auto Equipment Co.,
14th at Lawrence, Denver.
- CONNECTICUT**
Radio Inspection Service Co.,
247 Asylum Street, Hartford.
Stern Wholesale Parts, Inc.,
210 Chapel St., Hartford.
- GEORGIA**
Wholesale Radio Service Co., Inc.,
130 W. Peachtree St., N. W., Atlanta.
- ILLINOIS**
Allied Radio Corporation,
823 West Jackson Blvd., Chicago.
Newark Electric Company,
226 W. Madison Street, Chicago.
Wholesale Radio Service Co., Inc.,
801 W. Jackson Blvd., Chicago.
- INDIANA**
Van Sickle Radio, Inc.,
34 West Ohio Street, Indianapolis.
- MASSACHUSETTS**
Greater Boston Distributors,
40 Waltham St., Boston.
H. Jappe Co., 46 Cornhill, Boston.
Wholesale Radio Service Co., Inc.,
119 Federal Street, Boston.
Springfield Radio Co.,
397 Dwight Street, Springfield.
H. Jappe Co.,
37 Mechanic Street, Worcester.
- MICHIGAN**
Rissi Brothers, Inc.,
5027 Hamilton Ave., Detroit.

- MISSOURI**
Modern Radio Company,
409 No. Third Street, Hannibal.
Burstein-Applebee Co.,
1012-14 McGee Street, Kansas City.
Van Sickle Radio Co.,
1113 Pine Street, St. Louis.
- NEBRASKA**
Radio Accessories Company,
2566 Farnam Street, Omaha.
- NEW HAMPSHIRE**
Radio Service Laboratory,
1187 Elm Street, Manchester.
- NEW JERSEY**
Arco Radio Co.,
227 Central Avenue, Newark.
Wholesale Radio Service Co., Inc.,
219 Central Avenue, Newark.
- NEW YORK**
Wholesale Radio Service Co., Inc.,
542 E. Fortham Rd., Bronx.
Wholesale Radio Service Co., Inc.,
90-08 166th Street, Jamaica, L. I.
14th The Radio Man, Inc.,
64 Dey Street, New York City.
Eagle Radio Co.,
84 Cortlandt Street, New York City.
Federated Purchaser, Inc.,
25 Park Place, New York City.
Harrison Radio Co.,
12 West Broadway, New York City.
Sun Radio Co.,
212 Fulton Street, New York City.
Terminal Radio Corp.,
80 Cortlandt Street, New York City.
Thor Radio Corp.,
65 Cortlandt St., New York City.
Try-Mo Radio Co., Inc.,
85 Cortlandt Street, New York City.
Wholesale Radio Service Co., Inc.,
100 Sixth Avenue, New York City.
Radio Parts & Equipment Co.,
244 Clinton Avenue No., Rochester.
M. Schwartz & Son,
710-712 Broadway, Schenectady.

- OHIO**
News Exchange,
51 So. Main Street, Akron.
Canton Radio & Supply Co.,
1140 Tuscarawas Street, W., Canton.
United Radio, Inc.,
1103 Vine Street, Cincinnati.
The Hughes-Peters Electric Corp.,
178-180 N. Third Street, Columbus.
Standard Radio Parts Co.,
135 East Second Street, Dayton.
- OREGON**
Portland Radio Supply Co.,
1300 W. Burnside Street, Portland.
- PENNSYLVANIA**
Radio Distributing Co.,
1124-26 Market Street, Harrisburg.
M. & H. Sporting Goods Co.,
512 Market Street, Philadelphia.
Cameras Co.,
963 Liberty Ave., Pittsburgh.
- RHODE ISLAND**
W. H. Edwards Co.,
32 Broadway, Providence, R. I.
- UTAH**
O'Loukhlin's Wholesale Radio Supply,
315 South Main Street, Salt Lake City.
Radio Supply, Inc.,
46 Exchange Place, Salt Lake City.
- WASHINGTON**
Spokane Radio Co., Inc.,
611 First Avenue, Spokane.
- WISCONSIN**
Radio Parts Co., Inc.,
536-538 W. State Street, Milwaukee.

- TEXAS**
Amarillo Electric Co.,
111 East 8th Avenue, Amarillo.
- AUSTRALIA**
McGill's Agency,
185-184 Elizabeth Street, Melbourne.
- CANADA**
Winnipeg, Manitoba.
The T. Eaton Co., Ltd.,
Canadian Electrical Supply Co., Limited,
285 Craig Street W., Montreal, Que.
Metropolitan News Agency,
1248 Peel Street, Montreal, Que.
- CUBA**
The Diamond News Co.,
Palacio Asturiano, Por San Jose,
Habana.
- ENGLAND**
Gorringe's American News Agency,
9a. Green Street, Leicester Square,
London, W.1.2.
- HOLLAND**
Radio Peeters, Van Vovstraat, Amsterdam, Z.
- INDIA**
Empire Book Mart,
Box 631, Bombay.
- MEXICO**
American Book Store, S. A.,
Avenida Madero 25, Mexico City.
Central De Publicaciones,
Avenida Juarez, 4, Apartado 2430,
Mexico, D. F.
- NEW ZEALAND**
Te Aro Book Depot, Ltd.,
64 Courtenay Place, Wellington.
- SOUTH AFRICA**
Technical Book Co.,
147 Longmarket Street, Cape Town.

If this book is not at your dealer's, send your order directly to us. We will credit your dealer with the sale of this book. To order your copy of RADIO AMATEUR COURSE, fill in coupon below and mail.

RADIO AND TELEVISION, 99 HUDSON STREET, NEW YORK, N. Y.
Gentlemen: I enclose herewith my remittance of Fifty Cents (50c) for which please send me POSTPAID, my copy of the RADIO AMATEUR COURSE. (Remit by check or money order; register letter if you send cash or unused U.S. Postage Stamps.)

Name
Address
City State
R&T-1138

Be sure to see all future copies of RADIO AND TELEVISION for additional listings of dealers handling the RADIO AMATEUR COURSE.

RADIO AND TELEVISION
99 HUDSON ST. NEW YORK CITY

A FREE LESSON SHOWED BILL HOW HE COULD MAKE GOOD PAY IN RADIO

BILL, YOU'RE ALWAYS FOOLING WITH RADIO -- OUR SET WON'T WORK -- WILL YOU FIX IT?

I'LL TRY, MARY, I'LL TAKE IT HOME TONIGHT

I CAN'T FIND OUT WHAT'S WRONG -- GUESS I'LL MAKE A FOOL OF MYSELF WITH MARY

HELLO, BILL -- GOT A TOUGH ONE TO FIX? LET ME HELP YOU

HELLO JOE -- WHERE'VE YOU BEEN LATELY -- AND WHERE DID YOU LEARN ANYTHING ABOUT RADIO?

I'VE BEEN STUDYING RADIO AT HOME, BILL, WITH THE NATIONAL RADIO INSTITUTE. YOU OUGHT TO TAKE THEIR COURSE, I'VE GOT A GOOD RADIO JOB NOW. LET'S MAKE A CIRCUIT DISTURBANCE TEST -- STARTING WITH THE AUDIO OUTPUT STAGE AND TESTING EVERY STAGE RIGHT BACK TO THE ANTENNA. LISTEN FOR THE CLICKS WHEN I TAP THE GRID LEADS

SAY -- WHERE DID YOU LEARN THAT TEST? IT'S A GOOD ONE

HERE'S THE TROUBLE, BILL, IN THE FIRST I.F. AMPLIFICATION STAGE. I LEARNED THAT TEST EVEN BEFORE I STARTED TAKING THE COURSE, BILL. IT'S DESCRIBED IN A FREE LESSON WHICH THE NATIONAL RADIO INSTITUTE SENDS YOU WHEN YOU MAIL A COUPON FROM ONE OF THEIR ADS

I'VE SEEN THEIR ADS BUT I NEVER THOUGHT I COULD LEARN RADIO AT HOME -- I'LL MAIL THEIR COUPON RIGHT AWAY

I'M CONVINCED NOW THAT THIS COURSE IS PRACTICAL AND COMPLETE. I'LL ENROLL NOW AND THEN I CAN MAKE REAL MONEY SERVICING RADIO SETS OR INSTALL AND SERVICE LOUD SPEAKER SYSTEMS

OR GET A JOB WITH A RADIO BROADCASTING OR TRANSMITTING STATION

AVIATION RADIO, POLICE RADIO, TELEVISION, ELECTRONIC CONTROLS -- RADIO IS SURELY GOING PLACES. AND THE NATIONAL RADIO INSTITUTE HAS TRAINED HUNDREDS OF MEN FOR JOBS IN RADIO

I will send you a Lesson on Radio Servicing Tips FREE TO SHOW HOW PRACTICAL IT IS TO TRAIN AT HOME FOR GOOD JOBS IN RADIO



YOU CERTAINLY KNOW RADIO SOUNDS AS GOOD AS THE DAY I BOUGHT IT.

THANKS! IT CERTAINLY IS EASY TO LEARN RADIO THE N.R.I. WAY. I STARTED ONLY A FEW MONTHS AGO, AND I'M ALREADY MAKING GOOD MONEY.

THIS SPARE TIME WORK IS GREAT FUN AND PRETTY SOON I'LL BE READY FOR A FULL TIME JOB

Clip the coupon and mail it. I will prove I can train you at home in your spare time to be a RADIO EXPERT. I will send you my first lesson FREE. Examine it, read it, see how clear and easy it is to understand -- how practical I make learning Radio at home. Men without Radio or electrical knowledge become Radio Experts, earn more money than ever as a result of my training.

build circuits. This 50-50 method of training makes learning at home interesting, fascinating, practical.



J. E. SMITH
President
National Radio Institute
Established 1914

The man who has directed the home study training of more men for the Radio Industry than any other man in America.

OH BILL -- I'M SO GLAD I ASKED YOU TO FIX OUR RADIO. IT GOT YOU STARTED THINKING ABOUT RADIO AS A CAREER. AND NOW YOU'RE GOING AHEAD SO FAST

OUR WORRIES ARE OVER. I'M MAKING GOOD MONEY NOW, AND THERE'S A BIG FUTURE AHEAD FOR US IN RADIO

Why Many Radio Experts Make \$30, \$50, \$75 a Week

Radio broadcasting stations employ engineers, operators, station managers and pay up to \$5,000 a year. Fixing Radio sets in spare time pays many \$200 to \$500 a year -- full time jobs with Radio jobbers, manufacturers and dealers as much as \$30, \$50, \$75 a week. Many Radio Experts open full or part time Radio sales and repair businesses. Radio manufacturers and jobbers employ testers, inspectors, foremen, engineers, servicemen, and pay up to \$6,000 a year. Automobile, police, aviation, commercial Radio, loud speaker systems are newer fields offering good opportunities now and for the future. Television promises to open many good jobs soon. Men I trained have good jobs in these branches of Radio. Read how they got their jobs. Mail coupon.

I Also Give You This Professional Servicing Instrument

Here is the instrument every Radio expert needs and wants -- an All-Wave, All-Purpose, Set Servicing Instrument. It contains everything necessary to measure A.C. and D.C. voltages and current; to test tubes, resistance; adjust and align any set, old or new. It satisfies your needs for professional servicing after you graduate -- can help you make extra money fixing sets while training.

Get Sample Lesson and 64 page Book FREE -- Mail Coupon

In addition to my Sample Lesson, I will send you my 64-page book, "Rich Rewards in Radio." Both are FREE to anyone over 16 years old. My book points out Radio's spare time and full time opportunities and those coming in Television; tells about my Training in Radio and Television; shows you letters from men I trained, telling what they are doing and earning; shows my Money Back Agreement. MAIL THE COUPON in an envelope, or paste it on a penny postcard.

**J. E. Smith, Pres., National Radio Institute
Dept. 8MB3, Washington, D. C.**



**J. E. SMITH, President, Dept. 8MB3
National Radio Institute, Washington, D. C.**

Dear Mr. Smith: Without obligation, send me a sample lesson and your free book which points out spare time and full time Radio opportunities, and shows how I can train for them at home in spare time -- about the N.R.I. Set Servicing Instrument you give. (Please write plainly.)

Name Age

Address

City State

Many Make \$5, \$10, \$15 a Week Extra In Spare Time While Learning

The day you enroll I start sending Extra Money Job Sheets, show you how to do Radio repair jobs. Throughout your training I send plans and directions that made good spare time money -- \$200 to \$500 -- for hundreds, while learning. I send you special Radio equipment to conduct experiments and

HUGO GERNSBACK, Editor
H. WINFIELD SECOR, Manag. Editor
M. HARVEY GERNSBACK, Assoc. Editor

In This Issue

FEATURES

Television and the Public—Hugo Gernsback.....	389
The Television Torpedo—U. A. Sanabria.....	390
"Garden of Eden" for HAMS—Joseph Mitchell Boyer, W8PVL.....	391
The ARMY Amateur Network—Captain David Talley.....	392
Television Bares Its Secrets to Public.....	393
The "Curing" of a HAM—Daniel F. Foley, W2EUN.....	394
"Radioddities".....	395
More Experts Praise Radio Amateur.....	396
Radio Test-Quiz—Robert Eichberg.....	397
Receiving with the Flat-Top Beam Antenna—John D. Kraus, W8JK.....	398

S-W STATIONS—HOW TO FIND THEM

Short Wave Listening Tips—J. B. L. Hinds.....	402
Short Wave League—"On the Ham Bands"—Elmer R. Fuller.....	404
World Short Wave Stations—Edited by M. Harvey Gernsback.....	408

CONSTRUCTOR

Flat-Top "Beam" Antenna.....	398
Cathode-Ray Monitor for HAM Stations—C. W. Palmer, E.E.....	411
T.R.F. Television Receiver for 441-Line Reception—Henry Townsend.....	414
5 to 50-Meter, 6-Tube Superhet. Receiver—Harry D. Hooton, W8KPX.....	418
110 Volt Direct Current Transmitter—Herman Yellin, W2AJL.....	420

MISCELLANEOUS

The Radio Beginner—Lesson I—Martin Clifford, W2CDV.....	399
What Do YOU Think?.....	400
Silver Trophy Award for Best HAM Station Photo.....	401
Radio "Kinks"—Monthly Prizes.....	405
Question Box.....	406
New Short Wave Apparatus.....	407, 409

Cover composition by H. Gernsback and Thomas D. Pentz. Photos: top left—Milburne O. Sharpe, W4CED; top right—Edward Schmeichel, W9YFV; center—Dorothy Hall, W21XY; lower left—Wm. S. Burkhart, W4DLH; lower right—H. Leroy Vanderford, W2IDQ.

RADIO & TELEVISION—Published monthly on the tenth of the month. Entered as second-class matter Feb. 15, 1938, at the post office at Springfield, Mass., under the act of March 3, 1879. Trademarks and copyrights by permission of H. Gernsback. Text and illustrations are copyright and may not be reproduced without permission. Subscription price \$2.50 a year in the United States and possessions and Canada. \$3.00 in foreign countries. Make all subscription checks payable to Popular Book Corporation.

Published by Popular Book Corporation. Publication Office—29 Worthington St., Springfield, Mass. Editorial and Executive Offices—99 Hudson St., New York, N.Y. HUGO GERNSBACK, President; H. W. SECOR, Vice-President; EMIL GROSSMAN, Director of Advertising. European Agents: Atlas Publishing and Distributing Co., Ltd., 18 Bride Lane, Fleet St., London, England; Brentano's—London and Paris. Australian Agents: McGill's Agency, 179 Elizabeth St., Melbourne.

Copyright 1938 by H. Gernsback

In the Dec. Issue

How HAM Radio Helped to Film "Captains Courageous" — J. M. Goldby.
 T.R.F. Television Receiver—Henry Townsend—Part 2—Conclusion.
 An Emergency Transmitter for the HAM —Herman Yellin, W2AJL.
 3-Tube Ore Locator—Lieut. C. E. Chapel.
 Desk Type Transmitter—Alvin Abrams, W2DIT.
 Shooting Trouble on the HAM Transmitter.
 A Day with the YL's.
 A 1-Meter Receiver—N. G. Haas and C. A. Erbacher.



Lessons in Theory of Radio are broadcast every Monday evening at 8 p.m., E.S.T., on 6.04 mc. from station WIXAL (until June 12, 1939). Dr. C. Davis Belcher delivers the lectures. Course repeated every Friday evening at 5 p.m., E.S.T., on 11.79 mc. Diagrams to accompany lectures are available from station at cost.



Certified Circuits

When you see this seal on a set it is a guarantee that it has been tested and certified in our laboratories, as well as privately in different parts of the country. Only constructional—experimental sets are certified.

You need not hesitate to spend money on parts because the set and circuit are bona fide.

This is the only magazine that renders such a service.

MANY OPPORTUNITIES FOR THE COYNE TRAINED RADIO MAN



Are You Ready for a Better Job - More Pay?

Don't be an untrained man. Let me show you how to get your start in Radio — a fast growing, live money-making industry.

Prepare for jobs as Assembler, Inspector and Tester—Radio Sales or Service and Installation Work—Broadcasting Station Operator—Wireless Operator on a Ship or Airplane or Sound Work—HUNDREDS OF OPPORTUNITIES for a real future in radio!

12 Weeks of Shop Training

We don't teach by book study. We train you on a great outlay of Radio, Television and Sound equipment—on scores of modern Radio Receivers, actual Broadcasting equipment, Television apparatus and Sound Reproduction equipment, Code and Telegraph equipment, etc. You don't need advanced education or previous experience. We give you — RIGHT HERE IN THE COYNE SHOPS — the actual practice and experience you'll need for your start in this great field. And because we cut out all useless theory and only give that which is necessary you get a practical training in 12 weeks. Mail coupon for all facts about my school and training methods.

TELEVISION *and* PUBLIC ADDRESS

Television is sure to come as a commercial industry. Rapid progress is now being made in developing this new field. It will offer opportunities to the man who is trained in Radio. Here at Coyne you learn Television principles, and work on actual Television equipment. Public Address Systems offer opportunities to the Trained Radio Man. Here is a great new Radio field which is rapidly expanding. Prepare NOW for these wonderful opportunities! Learn Radio Sound Work at COYNE on actual Sound Reproduction equipment. Not a home study course.

SEND FOR DETAILS OF MY

"PAY AFTER GRADUATION" PLAN

Mail the Coupon below and I'll tell you about my "Pay After Graduation" Plan which has enabled hundreds of others to get Coyne training with very little money. On this plan you can get your training first, then take 12 months to complete your small monthly tuition payments starting 5 months after you begin training. Not a home study course.

Mail the coupon for all details of this "Tuition Payment Plan."

PRACTICAL WORK at COYNE in Chicago

ACTUAL, PRACTICAL WORK. You build and service radio sets. You get training on real Broadcasting equipment. You construct Television Receiving Sets and actually transmit your own Television images over our Television equipment. You work on real Sound equipment. You learn Wireless Operating on Actual Code Practice apparatus. We don't waste time on useless theory. We give you the practical training you'll need for your start in Radio—in 12 short weeks. If you desire code, this requires additional time for which there is no extra charge.

Mail Coupon Today for All the Facts

H. C. LEWIS, Pres. RADIO DIVISION Founded 1899

Coyne Electrical School
500 S. Paulina St., Dept. 88-2K, Chicago, Ill.

ELECTRIC REFRIGERATION AIR CONDITIONING AUTOMOBILE ELECTRICAL WORK

Instruction now included at no extra cost. Here is your opportunity to learn these valuable allied lines without extra tuition charge.

PART TIME EMPLOYMENT TO HELP YOU "EARN WHILE LEARNING"

If you are short of money and need part time employment to help pay for your room and board while training, my Employment Department will help you get a part time job.



GET THE FACTS

Don't let lack of money prevent your sending in the Coupon. Mail the Coupon today and I Will send you the Big FREE Coyne Book full of FACTS.

H. C. LEWIS, Pres.
Radio Division, Coyne Electrical School
500 S. Paulina St., Dept. 88-2K, Chicago, Ill.

Dear Mr. Lewis:—Send me your Big Free Radio Book, and all details of your "Pay After Graduation" Plan including valuable instruction in Electric Refrigeration, Air Conditioning and Automobile Electrical Work.

Name.....
Address.....
City..... State.....



HUGO GERNSBACK, EDITOR

H. WINFIELD SECOR, MANAGING EDITOR

TELEVISION AND THE PUBLIC

HUGO GERNSBACK, Editor

● WE come closer year by year, to the fulfillment of Television. The public, now quite well educated as to what Television really is, takes more and more interest in the subject as time goes on—which is an encouraging sign.

If I may draw a parallel, I might point out that Radio Broadcasting burst upon an incredulous world almost unannounced. The greater part of the public in 1920 had never heard the word "Broadcasting," and the few who had any knowledge of it, knew it only under the term "Radio Telephony." Furthermore, it was thought that the Radio Telephone was only the instrumentality used to communicate, without intervening wires, between two points: just as you would telephone to a distant friend by means of a wire telephone. The idea that everyone within the range of a transmitter could put up a receiving instrument and listen to speeches, music, etc., had never before penetrated the consciousness of the public and, when the stations sprang up like mushrooms in the early '20's, the public was taken almost unawares and had to be educated practically overnight.

Not so with Television, which now has, in one form or another, been before the public for many years. Indeed, the chief trouble with Television is that it has been overpublicized by irresponsible writers and others who made the public believe that Television was here, when indeed it was not. This has led to conditions directly the opposite from those which prevailed in the early days of Broadcasting and, while the public has been educated to Television, it has not been forthcoming up to now. This naturally created a great deal of disappointment, and the public rightfully begins to ask what is wrong with Television, and what is holding Television back?

I have answered these questions a number of times and stated that there is nothing wrong with Television, and that no one is holding it back.

Indeed, Television is perhaps more comparable to the automobile than to Radio Broadcasting.

If you will think back, you will find that we have had automobiles since Benz, in Germany, made his first car over fifty years ago. Thereafter there ensued a tremendous amount of experimenting with motor cars; but only during the last 20 years were automobiles really perfected to what they are today. It took a great deal of time to iron out all the "bugs," as technicians term difficulties, until the automobile became perfected.

Exactly the same condition is presented by Television. The television equipment which we have today is technically on about the same plane as the first automobile was in the late '80's of the last century. Certainly, Television today is not as far advanced as was the automobile of the vintage of 1900 or thereabouts. We then had good cars which ran, but they were not acceptable to the general

public, the reasons being first of all, their *high price* and, second, the lack of facilities for *repairs*; third, there were no *service stations* and, fourth, we did not have suitable *roads* on which to use cars had we had them. Exactly the same parallel is true with Television. The television equipment which we have today does the work; but it is not the final word, because many factors are still missing.

We still do not have the necessary thousands of transmitters all over the country. The entertainment part is yet an unsolved problem, due to the high cost of production and to the lack of advertising sponsors; who first must be brought into line to pay the cost of Television, because the Television Broadcasters will not be able to foot the bill, any more than the Sound Broadcasters do today. It is the advertising over the air which, in the last analysis, will be the most important link in the still unforged Television chain.

On the other hand, again citing the automobile analogy, there is the matter of cost of the Television receiver. The first automobiles cost anywhere from \$3000.00 to \$5000.00, and higher. The first Television receivers that give a clear picture run anywhere from \$300.00 to \$500.00; that is much too high a price for the public at large to pay. Not until production costs have come down, so that the average set can be bought for around \$25.00 to \$30.00 (as is the case with the popular priced radio receivers) will Television have arrived in earnest.

You cannot very well imagine this country absorbing 25 to 30 million Television receivers, even at a price of \$150.00 a set. We have nearly 30 million radio sets in the country now, but the average price of these receivers is probably less than \$30.00.

Once the popular-priced Television receiver makes its appearance, it will not be long before we have hundreds of thousands of such receivers in our homes.

As I have mentioned before, one of the unfortunate conditions in the Radio industry has always been that of stock-jobbing; that is selling worthless stocks to a gullible public. This was one of the things which gave Radio a black eye at the start, and is already giving Television a similar black eye, before Television has even stepped out of its swaddling clothes.

Television particularly has been a frequent victim of the stock-jobber, and the public has been taken in in the past, for hundreds of thousands of dollars in worthless securities put out by companies who were not equipped, technically or otherwise, to produce Television sets.

There is nothing revolutionary in sight in Television today and the fundamental television patents at the present time are closely held by large and powerful radio corporations; so, unless something of a revolutionary nature in Television comes along, no one in his right senses should put up a penny in buying Television stock.

November, 1938

The Television Torpedo

U. A. Sanabria

We predict this device will meet with the hearty approval of tomorrow's military experts.

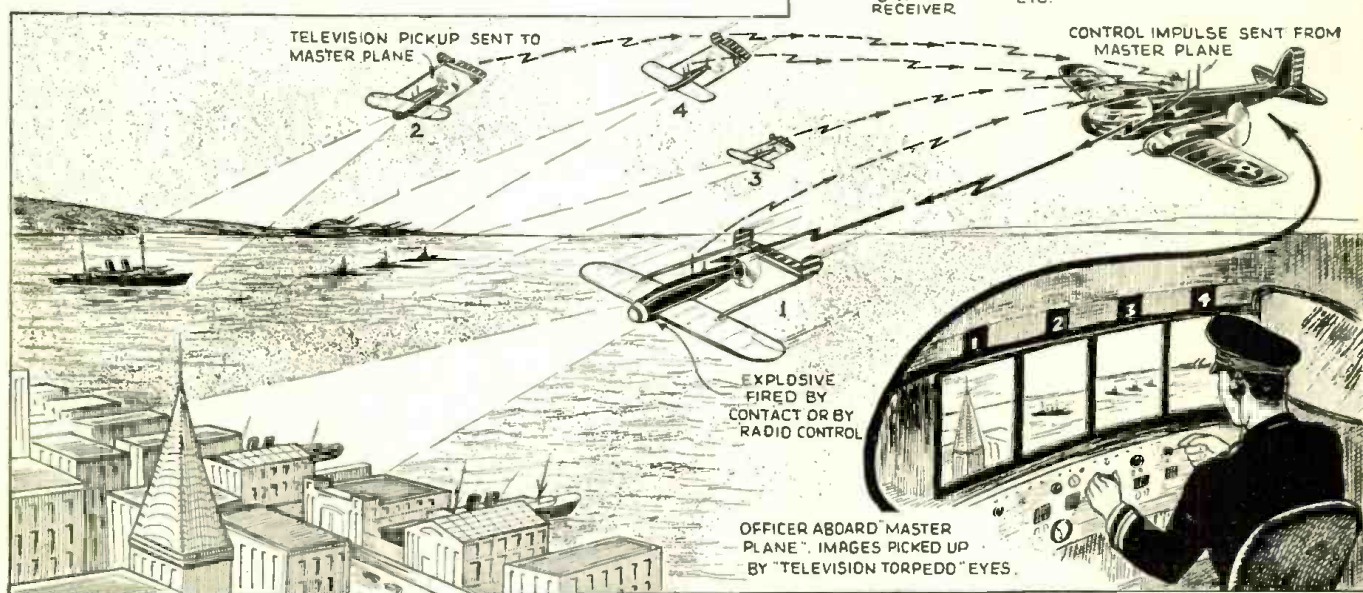

The illustration shows how the television torpedo transmits what it sees back to the master control plane. When a good enemy target presents itself, the control plane officer transmits a radio impulse which causes the torpedo to dive on the target and explode.

● IN recent months there has been increasing attention given to Television as a primary military force. All nations are vitally interested, and with excellent reason; the scope and versatility of this newest science is as astounding to the lay mind as it is unlimited to the General's.

You have probably heard of "Suicide Squadrons." They are the very latest tactical bodies in use by militaristic nations. Under the present application, they are in use in land warfare, aerial warfare and naval warfare. Deriving their nickname from their mode of operation, they presage certain death to the members of the operating staff. Under normal action a suicide squadron is composed of men who man explosive projectiles. The units they man are literally human bombs, filled with explosives and guided by human hands. It naturally follows that such projectiles are the most deadly which have been yet devised. In the form of land vehicles, aerial craft and water sleds, they are characterized by their high speed and extreme maneuverability. Useful as weapons of defense and offense, they concentrate upon destruction of the enemy at the cost of the life of the human operator. Such squadrons are comparatively rare, though, and the tacticians refrain from their use except as a last resort. In spite of the glory which attends the "suicide," men do not care to throw away their lives carelessly.

While this Television Torpedo could be applied to land and sea, let us consider it as applied to aerial warfare.

Imagine, now, a small, perfectly streamlined and radio-controlled airplane. Its

guiding transmitter is located in a larger plane. In addition to its radio receiver, this remote-controlled diminutive airplane carries a load of explosives in its fuselage, capped by the ordinary mechanism which sets off the blast upon contact with its target.

This radio-controlled torpedo has been successfully demonstrated and can be used at present if desired. However, it has one great *disadvantage* in its present form . . . the master plane and its transmitter must remain in close contact with it at
(Continued on page 430)

Clever Scene Change for Television Studios

Mr. Sanabria devised this scheme for presenting rapidly changing scenes on the translucent wall of a television studio by means of a projector; the scenes may be stationary or animated.

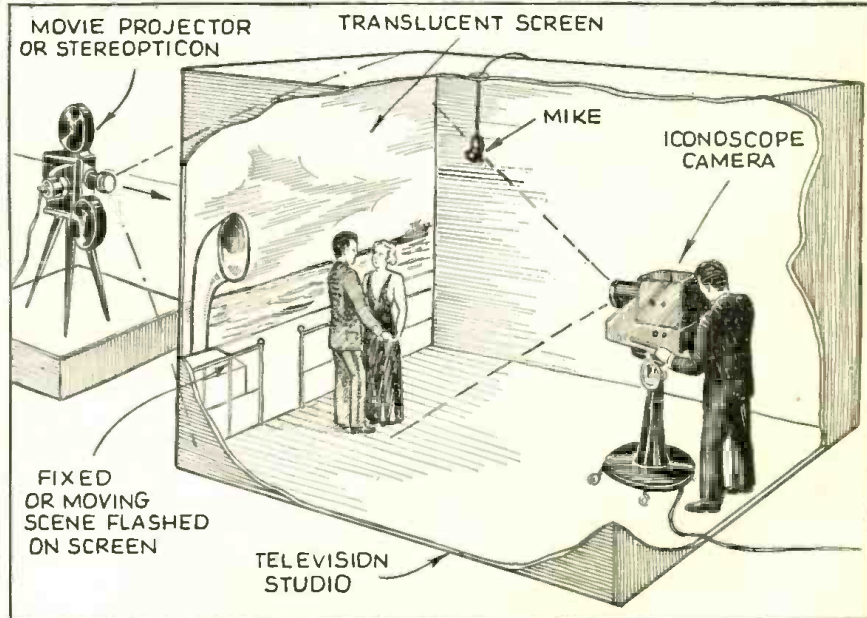

Oh, Boy! Look at this "Garden of Eden" for HAMS

Joseph Mitchel Boyer,
W8PVL

Tells How It
Was Created



Edison Institute Radio Club
Transmitter Room—Left to Right:
1—Universal power supply. Five
supplies in one rack for all trans-
mitters. 2—1.7 and 3.5 mc. 1 kw. phone
transmitter. Final stage 204A's in push-
pull. 3—3.5, 7, and 14 mc. 1 kw. cw. trans-
mitter. Final stage 150 T's in push-pull.
4—14, 28, and 56 mc. 1 kw. cw. and phone
transmitter. Final stage 300 T's in push-pull.

● WHAT radio amateur has not, at some time or other, settled back in his chair; shut off the pet pile of junk; lit up the old briar, and let his thoughts dwell on "that dream rig" he is going to build the first day his "dream ship comes in"? A kilowatt? Oh sure. Nothing like a husky fire in the main tank to poke a signal through modern day QRM. And flexibility? Say! this dream station of ours will hop from one band to the other like a rabbit. And on it goes; none of us ever see that rig, but at least it's good mental exercise. Of course I know most of the "young squirts" (unless you're over 400 years old, you belong to this group) keep their weather eye peeled. They still are not convinced of the fact that fairy godmothers have long gone out of circulation. One *might* turn up who would consent to coughing up just such a layout.

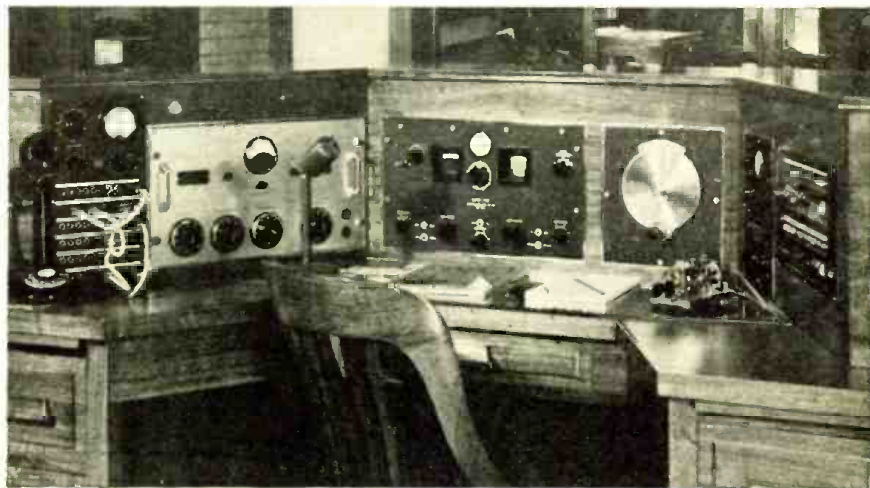

▲ Apparatus on operating console from left to right:
1—Speech amplifier control, DB meter and patch panel.
2—Pre-amplifier and three channel mixer. 3—Hammarlund
Super-Pro receiver. 4—100 kc. crystal band marker and
monitor. 5—2 inch cathode ray oscillograph, for monitor-
ing. 6—Control panel, controls all apparatus in the station.

◀ The low station building stands framed in its towering an-
tenna masts. Each tower is outfitted with a string of
aircraft warning lights.

The author was beginning to think his luck had deserted him in this respect, when he happened to wander into the radio version of EDEN. The boys of the Edison Institute Radio Club were its guardians and, strangely enough, its creators. They had solved our problem. I saw it: my *dream station*, but no fairy godmother had pulled it from her bag of tricks. These stout fellows were their own conjurers. Instead of sitting back and dreaming, they ganged up and made their own Utopia.

Slowly, under the able guiding of the present staff,
(Continued on page 443)

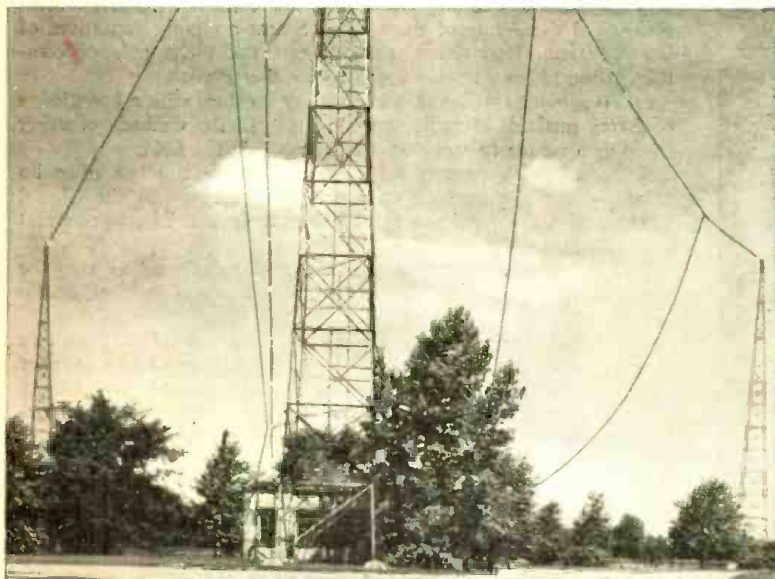

The ARMY Amateur Network

Captain David Talley, Sig.-Res. Radio Aide, 2nd Corps Area

One of the Leaders in Army Amateur Communications
Tells the Inside Story of This Little-Known Net.



The Author, at the radio shack of an Army camp.

● ALTHOUGH the great value of the radio amateur or "Ham" as he is colloquially known, to the national defense of our country was first demonstrated more than twenty years ago during the World War, it is in the more recent years, when floods, fires, tornados, hurricanes and earthquakes had seriously damaged or destroyed wire communications, that the amateur radio operator's value to his community has again

been brought to the attention of the general public, as evidenced in many newspaper articles. At first, as during the Miami and Puerto Rican hurricanes of 1926 and the Vermont floods in 1927, the amateur's emergency communication work was organized in a more or less temporary manner due to the exigencies of the situation, and the fact that radio communication to and from the stricken areas was established and maintained (despite the lack of organization and training of the participants) was due to the loyal cooperation of the individual amateurs who volunteered their services and radio equipment for the period of the emergency without thought of their personal affairs or physical comforts.

History

The potential public service of the radio amateur was instrumental in gaining the early recognition of the War Department which, through the Signal Corps of the Army, in 1925 began to develop a nation-wide organization of radio amateurs trained to provide their communities with reliable radio communication in emergencies. This organization was designated the

LEFT: Emergency Unit Trailer of Ira Lou Spring Post 149, American Legion, Jamestown, N. Y. Right: Front end of the unit, showing the transmitter and receiver (which has been replaced); other apparatus is at trailer's rear.

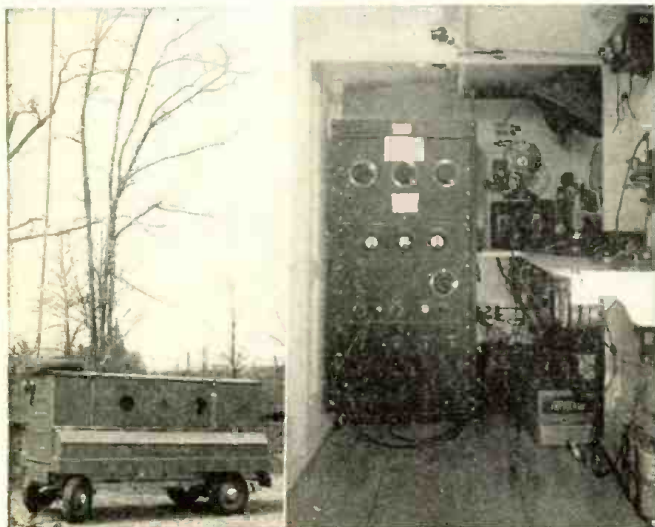

ARMY AMATEUR RADIO SYSTEM and it has grown since that time to more than 1,300 active members at present located throughout the United States and its possessions and all are trained in Army radio procedure and methods of operations in emergencies.

Purpose

The ARMY AMATEUR RADIO SYSTEM is a non-military organization of active transmitting radio amateurs who are affiliated with the Signal Corps of the Army for the following purposes:

1. To provide additional channels of radio communication throughout the continental limits of the United States that may,



Sgt. Charles May copying a message at the receiving position of W2SC-WLN, Governors Island, New York.

in time of emergency, be used to augment or replace the land lines, both telephone and telegraph, that might be seriously damaged or destroyed by flood, fire, tornado, earthquake or other disaster.

2. To place at the disposal of military commanders of all components of the Army of the United States and representatives of the American Red Cross, the amateur radio channels of communication as may be developed under this Plan.

3. To provide civilian amateur radio operators with a knowledge of Army methods of radio procedure and of the methods of using radio as a means of signal communication in the field.

4. To establish contact with a considerable number of radio amateurs for the purpose of acquainting them with the Signal Corps and its activities and securing their aid in experimental work, tests, etc.

5. To render such encouragement and assistance as may be desirable to firmly establish and perpetuate the American Radio Amateur.

It may be well, at this point, to state that no military service of any nature is required or expected at any time of any member of the A.A.R.S. The organization is a voluntary cooperative society of amateur radio operators who, realizing their duties and responsibilities as American citizens, desire to train themselves to better serve their country and community in emergencies when normal communication channels are temporarily destroyed. Any amateur radio operator duly licensed by the Federal Communications Commission and who has his or her radio station in active operation, is eligible to join the A.A.R.S.

(Continued on page 433)

Television

Bares Its Secrets to Public

TELEVISION HAS TECHNICALLY BEEN DEVELOPED TO A HIGH DEGREE. THIS ARTICLE PROVIDES THE LATEST INFORMATION. IT WILL BE SOME TIME BEFORE HOME TELEVISION IS REALIZED. THE ART HAS GREAT OPPORTUNITIES FOR EXPERIMENTERS AND TECHNICIANS.

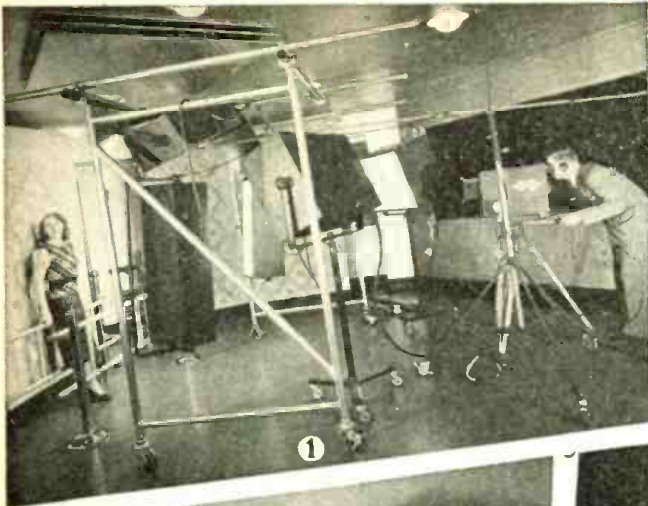

1



3



4

The public can now see just how television works—thanks to the new "television tour" recently organized by the National Broadcasting Company. A guide explains steps in transmitting and receiving images.

Photo (1) shows studio where visitors are televised; (2) "Miss Television" poses before the studio lights. (3) One of the image receivers, with mirror to show "the works". (4) Betty Goodwin inspects an old type scanning apparatus.



2

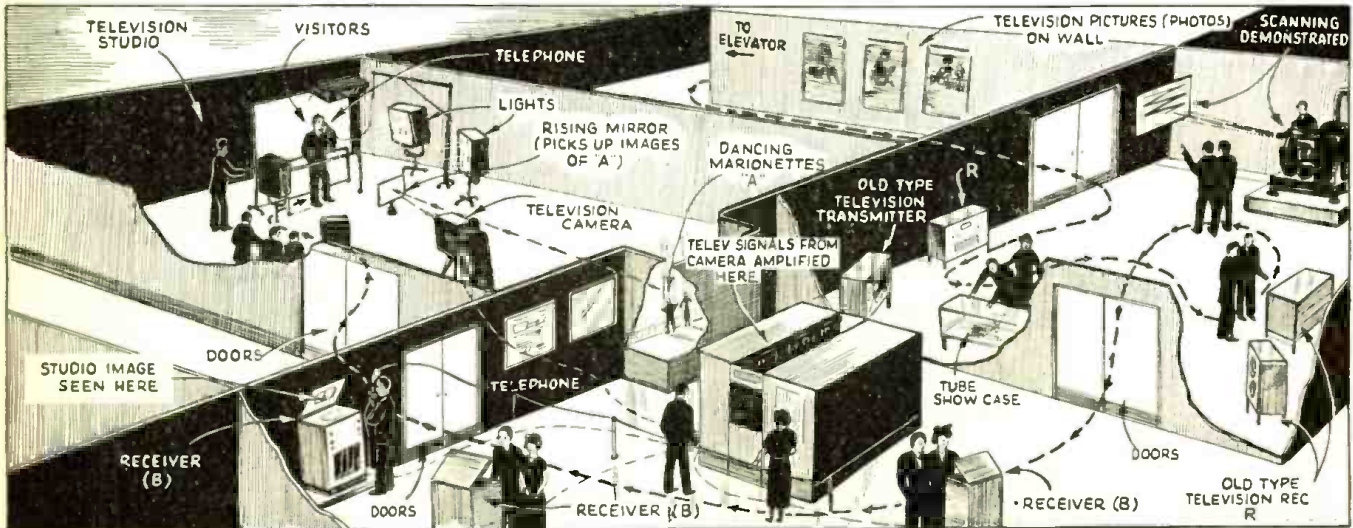
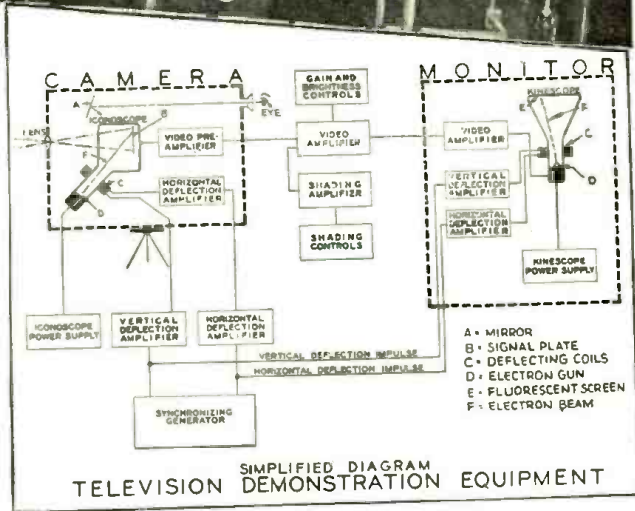

The "Curing" of a HAM

Mr. Foley here describes in his own inimitable style some of the experiences a "ham" meets when taking his Government license test. Imagine the thrill when a "ham" makes his first contact on the air—but let Mr. Foley tell it.

Daniel F. Foley, W2EUN

● TODAY, I am a Ham. A full-fledged, fully cured Ham! Don't think, however, that I metamorphosed easily.

It all dates back to a day in August, when rain steamed and teemed on the street outside, and I, under the quickening influence of copious *How-to-Become* literature, made the resolution. Before then, I had had reason, many times, to wonder about the old story that hobbyists, being fools, are always "taken in." Now, I hope it's true. At least, if they're "taken in," they always, as G. K. C. puts it, "see the inside of everything," while their more sophisticated brethren are kept out.

My vow to be a Ham once definitely accepted, there followed lengthy, arduous penances. I would sit cloistered between two Inquisitorial earphones, bringing to me the erratic "dits" and "dahs" stuttered out by the Lord's grace, a bored brother, and what seemed to be an equally bored key. To further evolve the Marconi in me, we carried on all conversation in Code. For the advantage gained I paid one large fee in the coin of embarrassment. You can imagine the fright of Mrs. Prendergast when, to her pleasant "Good Morning!" I gave out with, "Dah dah dit, dah dah dah—"

My code speed increased rapidly. One, two, three w.p.m. whizzed by; four, five

breezed—an August breeze; I walked through six at a Bernarr Macfadden "clip"; seven, eight—out of breath; nine, ten—cut your throat! These last two steps were traversed at a belly-scraping grovel.

Since all storms must end; since I was tenth-century anchorite, *bridgeur enragé*, and Thomas Lipton rolled into one, the moment finally ticked (I almost said "dicked") when I could copy not ten but eleven w.p.m. That's the funny part of it! After repeated attempts to drag my weary ear from nine to ten, and always slipping to seven or eight, suddenly I could copy eleven!

Gangway for the F.C.C. Office!

A week to prepare for the written examination and—gangway for the F.C.C. office!

I arrived there one morning about 9:30, a breakfast of "Super-Inflated Scrunchies" still heavy on my stomach. First an application—"Was I an alien?" "Was my home owned by an alien?" "Were there any aliens in my family?" Then it must be notarized. (I thought I'd never stop swearing that day.)

At long last the examination. My pulse seemed normal; I was breathing without difficulty. All in all, the situation seemed

(Continued on page 429)

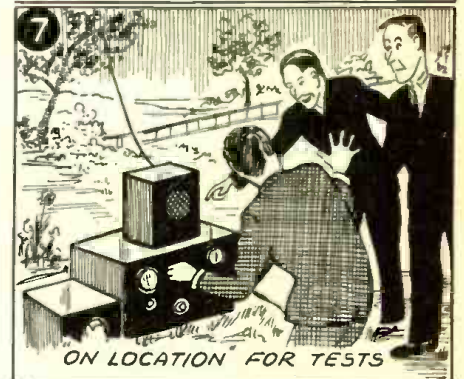
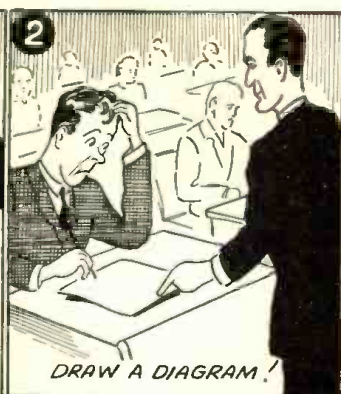
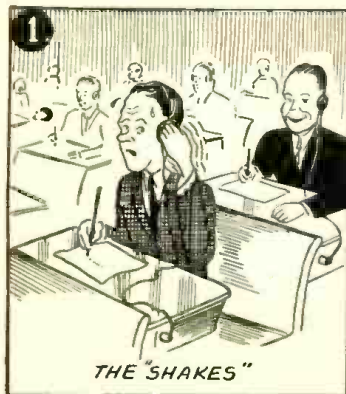

"RADIODDITIES"



AN ALERT LITTLE BOY IN E. RAHWAY, N.J. RIGGED UP A COPPER WIRE ANTENNA WITH WHICH HE CATCHES ENOUGH POWER TO LIGHT UP HIS PLAYHOUSE.



PEOPLE WITHIN A HALF MILE RADIUS OF THE TRANSMITTER REPORT THAT THEIR CAST-IRON DEER IS GIVING OUT CORRECT WATCH TIME

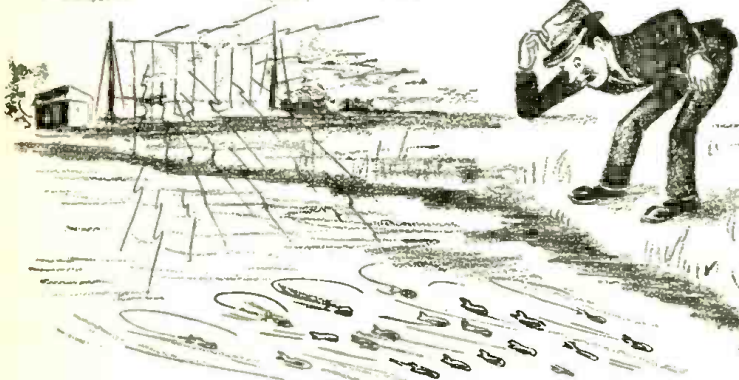

WOR'S PROGRAMS ALSO HAVE AN EFFECT ON THE LOCAL FISH; ONE ENGINEER STANDING ON THE BANK OF A STREAM, SAW A WHOLE SHOOL OF KILLIES TURN AND SWIM IN THE OPPOSITE DIRECTION JUST AS THE TRANSMITTER STARTED A SHORT-WAVE BROADCAST.

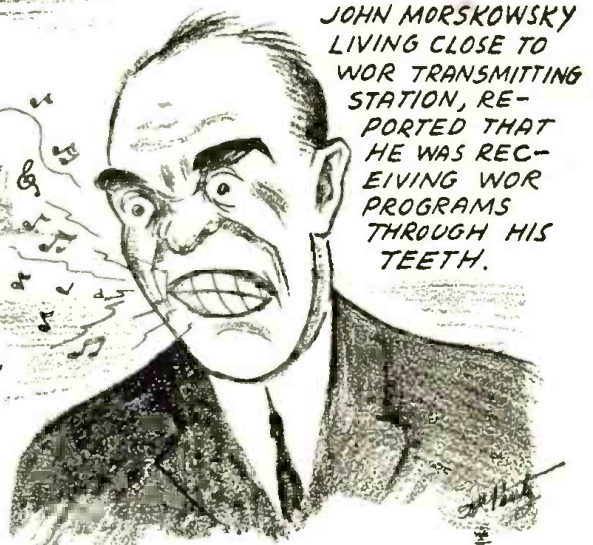

JOHN MORSKOWSKY LIVING CLOSE TO WOR TRANSMITTING STATION, REPORTED THAT HE WAS RECEIVING WOR PROGRAMS THROUGH HIS TEETH.



THE WOR RADIO STATION PROGRAMS ARE BROADCAST FROM 2-385 FT. TOWERS IN E. RAHWAY, N.J., AND THE PEOPLE LIVING IN THAT VICINITY EXPERIENCE PECULIAR "GOINGS ON". WHEN THEIR RADIOS ARE TURNED OFF, WOR PROGRAMS COME IN THROUGH THE KITCHEN STOVE AND PLUMBING.

\$5.00 For Best "Radioddity"

• THE accompanying pictures show a number of freak radio reception conditions which actually occurred in the vicinity of WOR's transmitter. The editors will pay a \$5.00 monthly prize for the best "Radioddity" sent in by our readers. The description should be about 150 words in length and may be accompanied by a sketch or photo. The occurrences described must be based on fact, like those here illustrated.

If you have never run across any "Radioddity" of any nature, you may be able to act as a reporter for us by interviewing radio friends and engineers, especially those connected with broadcasting stations. You will probably pick up some very amusing Radioddities.

For the best Radioddity submitted each month, the editors offer a \$5.00 prize. Others, whose contributions are used, will receive a 1 year's subscription to RADIO & TELEVISION. In the event of a tie between two or more contestants, an equal prize will be awarded to each.

Closing date for the first contest is November 10th. Prize-winning contributions will be published in the January, 1939, issue.

Address all contributions and communications to

Editor, Radioddities
RADIO & TELEVISION MAGAZINE,
99 Hudson Street,
New York, N. Y.

More Experts Praise Radio Amateur

ROBERT H. MARRIOTT
Consulting Engineer



"Bob" Marriott was responsible for the organization of the Institute of Radio Engineers. He has had many important assignments including the position of Expert Radio Aide to the U.S. Navy during the World War.

● THE radio amateur, as I knew him first, was immature, a kid in short pants. His mother loved him and commercial radio operators hated him. Navy radio operators and officers rated him from third-class to chief radio nuisance. Operators rated the amateur higher than their bosses rated him, because if operators did not receive the messages they should receive, they blamed the failure on static in summer and on amateurs in winter.

Beginning in 1912, as a U.S. radio inspector at New York, I helped police the amateur. Because New York had so many radio problems per square mile, that city was the first proving ground for the inspection service. The early results obtained in New York molded policies for other districts and for radio in general.

By 1912 the feeling toward the amateur had not improved. If a professional radio operator or engineer wanted to belittle another professional or radio device he called them amateur. Occasionally a professional would admit that being a radio amateur might contribute to the amateur's education and keep him off the streets and away from pool-rooms and saloons. But he frequently added that the amateur fooled with radio when he should be doing his homework, and he usually wound up with the prophecy that the amateur would soon be eliminated. Commercial forces, military interests, new radio law and U.S. radio inspection service were supposed to make up the combination of afflictions that would result in the hoped-for and predicted demise of the amateur.

(Continued on page 422)

IRVING VERMILYA, WIZE



Mr. Vermilya, one of the real early "hams," is still going strong. He contributed articles to many of the early radio journals and at present he is General Manager of Broadcast Station WNBH, New Bedford, Mass.

● WHEN the Radio-Bug hit me, back in 1901, it hit deep. for I am still an active ham after all these years. My present call WIZE has been with me for the past 22 years, and today I am still on the air with one kilowatt on 75 meter phone, 80 c.w. and another kilowatt rig on 160 phone and 160 c.w. I also run 800 watts on 5 meters, and although little was ever published about my station, I believe I have the highest antenna mast of any ham for miles around. It is exactly 170 feet high!

I am deeply interested in radio and not a day goes by but what I am on the air on some of the bands.

I have five transmitters and four receivers, and keep more crystals on hand than a radio store: have just 50 Bliley crystals on hand at the station.

Besides being a ham at heart, my everyday job is general manager of Broadcasting Station WNBH in New Bedford, Mass., which station I formerly owned. I also own a Police Transmitter WPFN, and rent the service out to the City of New Bedford, Mass., on a 24-hour per day basis.

My automobile contains one broadcast receiver, one police receiver, three loud speakers, one 5-meter transmitter 35 watts input, one 5-meter receiver, 2 horns and an electric heater. The storage battery in the car weighs 144 pounds—25 plates to a cell—250 ampere capacity and has a special generator to charge it; can charge as high as 30 amperes. I regularly work 30 miles with my home station from the car.

The 5-meter rig is so attached at the home station, that I can call anybody who has a regular telephone in their home and talk to them from my automobile—2-way. Many times I go out motoring on a Sunday and take a telephone book with me, so that I can call up my friends. The only restriction on this stunt is that I must stay within about 15 or 20 miles of the home station.

Famous Radio Experts "Salute" to the Amateur

Appeared in the October number—Don't fail to read it!

J. R. POPPELE
Chief Engineer, Station WOR



Mr. Poppele, another radio pioneer. His word to the radio amateur will be highly appreciated, for he has had the opportunity of knowing of the fine work the amateur has accomplished.

● IN the whirl of our modern and high speed broadcasting industry, it seems to me that we are too prone to overlook the quiet, unassuming contributions to this great science which our amateur radio experimenters have made during the past three decades.

I made my own start as a youthful amateur operator in the days of rough spark notes and simple galena detectors, using the call letters 2AEY. Since that time, nearly thirty years ago, I have watched with interest the contributions to radio broadcasting which have come from thousands of unnamed amateurs throughout the nation, many of whom have won for themselves positions of great importance in our ever-growing industry.

Even today, when WOR—the powerful 50,000 watt station of which I am proud to be chief engineer—pioneers in the new field of facsimile, it gives me pleasure to note that hundreds of inquiries for information on this new service of radio come from amateurs, forging ahead of progress throughout the land. Both facsimile and its

(Continued on page 422)

AUSTIN C. LESCARBOURA
Public Relations Counsel



Austin Lescarbourea has helped to guide the onward march of radio in America. As public relations counsel and as the author of numerous radio articles and books, together with his early experience as a "ham," Mr. Lescarbourea's message is important and timely.

● TO one who has been privileged to pioneer in radio activities all the way back to "wireless" days, the present and future of amateur radio are just an open book. Amateur radio is and must continue to be a blazing of the trail into new frequencies and possibilities, with the commercialized art following through in due course. Also, amateur radio must be the great recruiting and training camp for the future personnel of the radio industry.

I well remember, back in 1907, how we wireless amateurs worked with spark coil and coherers in spanning a mile or two between ourselves. With untuned transmitters and receivers, we had the full run of the ether, much to the annoyance of nearby commercial and Government stations. Later, in 1912, came the policing of the ether. Amateurs were soon kicked off the wave lengths above 200 meters and forced to get along in the then short waves. And as amateurs conquered the intricacies of these lower wave lengths and covered amazing distances with modest power, the commercial and government interests came into these lower wave lengths and again shoved the amateurs to still lower wave lengths. Each time the amateurs have exploited these seemingly barren radio territories to the utmost, and have demonstrated the silver lining to dazzled commercial and governmental professionals.

Television, I personally insist, is an amateur's problem primarily. While the big interests may be set on bringing into being a completely workable system for lay operation in the living room, I believe that the many remaining technical problems had best be worked out on an amateur basis. It seems too bad that there has not been greater amateur activity in television. Indeed, the amateur has been discouraged by statements that television technique is far too intricate to be essayed by the home builder. But in the final analysis, the many "bugs" bound to turn up in a commercialized attempt at television might better be worked out by amateurs serving as part of the engineering and laboratory personnel.

And so I say, the amateurs must continue to blaze the trail. Already they have given us low-power communication in the short-wave and ultra-short-wave fields. Today's immediate projects would seem to be directional transmission and reception, very low power possibilities of portable transmitters, facsimile communication, and television. And with these immediate projects soon conquered, the amateurs of tomorrow can move on to still newer fields.

The radio industry can consider itself more than fortunate in having this vanguard of ardent pioneers and practical workers, whose only reward is the sheer joy of achievement.

RADIO

TEST-QUIZ ?

Meet Your
Professor —

Robert
Eichberg

● **HERE'S** a quiz to test your knowledge of Radio and Television. A perfect score is 100%; that's what you get if you know the answers to all 25 questions. To get your rating, count 4 for each question you answer correctly, or 2 for each question you get half right. The total indicates your score. Average ratings are:— Novice, under 50; Experimenter, 50 to 60; Serviceman, 60 to 75; Engineer, 75 to 95; Genius or Liar, over 95.

1. The teacher gave Willie an "A" for defining Marconi as

- The man who invented radio waves.
- The first man to demonstrate radio.
- The first man to span the Atlantic ocean.
- A heavy cambric tubing used as insulation.

2. As if you didn't know, Broadcasting consists of

- Tossing a wild adagio dancer into the air.
- Sending telephone messages by radio.
- Sending out radio signals to anybody who can afford a receiver.
- Yodelling "Flat Foot Floogie" into a cringing mike and thence through a P.A. system.

3. According to the authorities, a crystal, as used in radio, is

- Something a good set sounds as clear as.
- A piezo-electric oscillator.
- The "diamond" in a 50-cent engagement ring.
- A natural substance used to transform electrical pulsations into mechanical motion.



4. If you knew the broadcasters in the left-hand column well enough to call them by their right names, which of the names in the right-hand column would you address them by?

- | | |
|---------------|-------------|
| A. Jack Benny | a. Lopez |
| B. Ben Bernie | b. Kubelsky |

- Joe Cook
- Fred Allen
- Priscilla Lane
- Eddie Cantor

- Mullican
- Iskowitz
- Ancelovitz
- Sullivan

5. "You can't kid me," stormed the editor, "a negative carrier is—"

- The negative lead in a power pack.
- A delivery boy for photographic supplies.
- The negative plate of a polarized condenser.
- A negative ion.

6. Most modern American television apparatus makes use of the

- Nicoll prism
- Kinescope
- Iconoscope
- Stethoscope
- Nipkow disc

7. One of the following abbreviations does not refer to the covering of a wire. Ah, but which?

- | | |
|--------|--------|
| a. ssc | d. ese |
| b. sse | e. dcc |
| c. dsc | f. sce |



8. It should be generally known that the radio amateur hour burst into new popularity a year or two ago after it had been brought back by

- Major Edward Bowes
- Perry Charles
- Nick Charles
- Fred Allen
- Henry Simmons

9. When you stick a pair of live D.C. leads into a glass of water, bubbles arise from

- Both leads
- The positive lead
- Neither lead
- The negative lead

10. A new system of transmitting television signals was recently patented by

- Rinsky Korsakoff
- Ivan Offulitch

- Vladimir Zworykin
- David Rubinoff
- Niblya Irzoff

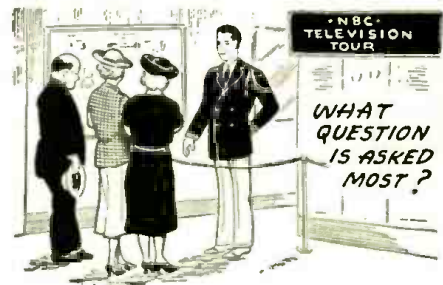

11. According to the National Broadcasting Company pages, who take visitors on a "Television Tour," the question most frequently asked is

- When will television be ready for the public?
- How much will a television receiver cost?
- Does it hurt to be televised?
- When will we have color television?
- How far can you transmit television?

12. Which of the following would a newspaperman be more likely to use than would a ham or SWL?

- | | |
|---------------|-------------|
| a. Wouff-hong | d. 30 |
| b. 73 | e. Hell-box |
| c. 88 | f. CULOM |

13. You find two of these, in diluted form, in a storage "A" battery. Which is it?

- | | |
|----------------|----------------|
| a. CO_2 | d. H_2S |
| b. $NaOH$ | e. H_2SO_4 |
| c. $C_{10}H_8$ | f. C_5H_{10} |

14. It is customary to couple the grid and plate of a triode together when the tube is to be used as

- An R.F. amplifier.
- A beat frequency oscillator.
- A modulator.
- A half-wave rectifier.
- An A.F. amplifier.
- A super-diodyne detector.

15. When radio waves go bouncing around on a strata of ionized gas, they are being reflected by

- The Heviside Layer.
- The Kennelly-Heaviside Layer.
- The Heaviside Layer.
- The Kenelly-Heviside Layer.
- The Kenealley-Heavyside Layer.
- The Kennelly-Heaviside Layer.

16. The cap on the top of every tube that

(Continued on page 430)

Receiving with the Flat-top Beam Antenna

John D. Kraus, W8JK

A leading expert explains how to erect a real DX-getting antenna. Two types of flat-top beams suitable for receiving amateur signals in the 14 mc. band are described; also a directivity switching scheme.

● **SHORT-WAVE** reception from all directions is usually accomplished by means of a general coverage antenna. A half-wave doublet is an antenna of this type and gives quite uniform reception from all directions. Often, however, a short-wave listener desires to improve his reception from a certain locality over that obtainable with a simple half-wave type of antenna. For this purpose a directional or beam antenna is used. Such an antenna can (1) increase the strength of signals received from certain directions and (2) at the same time reduce the pick-up of signals and interference arriving from other directions. Generally, these two functions go together in a directional antenna and both are helpful for improving the reception of signals coming from the preferred direction.

The Flat-Top Beam

The "flat-top beam" is a directional antenna which is both effective and quite compact. This antenna¹ is useful for both transmitting and receiving. The directional characteristics of the antenna are similar whether it is used for transmission or reception. Also the dimensions and general construction are the same in both cases.

¹See "Radio" for March, June and December 1937 and June 1938; QST for January 1938; and "Television and Short-Wave World" (London) for February 1938.



Figure 2. Approximate coverage of a 2-section flat-top beam at Washington, D. C., with the maximum response centered on Sydney, Australia. This direction is broadside to the antenna. The antenna itself runs approximately north and south (more exactly 8° W. of N. and 8° E. of S.). The shaded area indicates the angle over which maximum improvement is obtained.

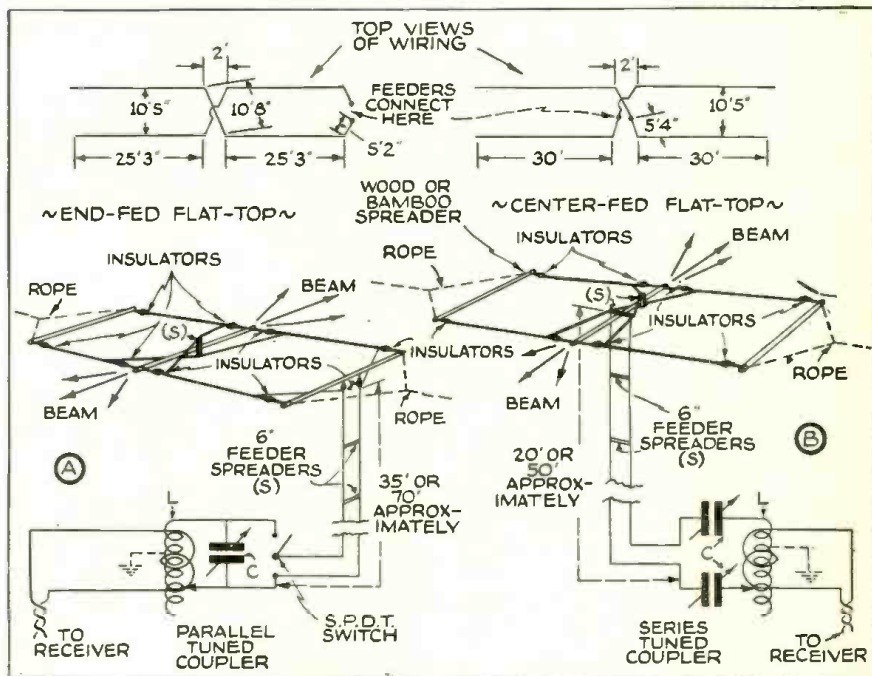

Figure 1. Two types of flat-top beam antennas for receiving 14 mc. amateur signals. "A" is a 2-section end-fed flat-top and "B" is a 2-section center-fed type.

With a transmitter at ones disposal there are a number of methods by which the antenna may be fed and tuned. However, when no transmitter is available, some of these methods are quite difficult to apply. For this reason, only one of these methods, namely that employing Zepp feeders and a coupler unit at the receiver, is recommended when the beam is used entirely as a receiving antenna. It is the purpose of this article to describe two types of flat-top beams as used in this manner for short-wave reception.

Dimensions

Two types of flat-top beams suitable for receiving amateur signals in the 14 mc. band are shown in Figure 1. Both of these antennas consist of a horizontal flat-top portion which picks up the signal and a pair of feeder wires connecting the flat-top to the receiver. The feeders in the antenna of Figure 1-A connect at one end of the flat-top. Hence, this type is called an end-fed flat-top. The antenna of Figure 1-B has the feeders connected at the center and is called a center-fed type.² Both

²The use of this type of antenna for receiving Asian amateurs was described by Joe Miller in the DX column of S. W. & T. for August, 1938.

types consist of a pair of horizontal wires spaced 10 feet 5 inches. These wires cross over at the center of the antenna, dividing it into two sections, each approximately one-half wavelength long. The overall length of the end-fed type is about 53 feet and the center-fed about 62 feet.

Both of the antennas of Figure 1 are very similar in operation. The choice of which one to use is largely dependent on which is the more convenient to install. Both provide a substantial improvement to signals received broadside to the antenna and have a minimum of response off the ends.

Where a spacing of 10 feet 5 inches is inconveniently large, a spacing of 8 feet 8 inches may be used. All the other dimensions of the antennas remain the same, except that in the case of the end-fed type, the sections are each made 26 feet 4 inches long instead of 25 feet 3 inches. The wider spacing, however, is slightly more efficient.

It should be pointed out that none of the dimensions of the antennas is critical, since, as will be described, both are tuned by means of a coupler unit at the receiver.

Hence, no noticeable difference in operation is observed.

(Continued on page 439)

The Radio Beginner

A New Series

Lesson I

Martin Clifford, W2CDV

In response to many requests, the editors here present a new series for the radio beginner. The first lesson deals with the electric current, the magnetic field and the difference between direct and alternating current.

● ONE of the most formidable things that apparently confronts the would-be student of radio is the commonly mistaken notion that a mastery of the various difficult branches of mathematics is required. Fortunately, however, radio can be taught in either one of a number of ways. The most scientific, of course, is through the use of complicated formulae, but a good and completely adequate *working knowledge* of radio can also be secured by means of simple description, in easy-to-understand language, with the help of analogy. Thus, for example, we can either describe condenser action by mathematics, or else we can say that a condenser stores energy somewhat in the same manner that a glass will hold water. It takes energy to pour water into the glass, and it also takes energy to "pour" an electric charge into a condenser. But in both cases, the energy can be retrieved. This is a simple example of what we mean by teaching radio through analogy.

Passage of Electric Current

When we think of radio we very naturally think of electricity. To attempt some explanation of the present-day theory of electricity would lead us far afield into the complicated realm of atomic physics.

For our purpose suffice it to say that an electric current is thought to consist of a flow of tiny particles, each bearing a negative charge, and technically known as *electrons*. These electrons do not move with the same ease through all matter. For example, they do not move so easily through a piece of iron wire, because the molecular structure of iron wire is such that (for some reason not yet thoroughly understood) it interferes with electrons flowing through it. Electrons flow much more freely through copper wire and still more freely through wire made of silver. Substances that permit the free passage of electric currents are called *conductors*. There is no known substance in the world that will not permit the passage of a certain amount of electric current, but there are a few substances that pass so little that for practical purposes they are called *non-conductors* or *insulators*.

Magnetism

When we think of radio, we not only think of electricity, but also of *magnetism*. Every one of us is quite familiar with the ability of a small horseshoe magnet to pick

up iron nails. And yet this apparently simple action is of great importance in radio, and, as will shortly be seen, has a close relationship to the flow (so-called) of electric currents.

If we were to take a bar magnet, cover it with a piece of cardboard, and then sprinkle iron filings over it, we would very quickly see that the iron filings arrange themselves in what appears to be a very definite pattern or field. Actually, the filings follow what is known as *magnetic lines of force*. We could also detect these lines of force through the simple expedient of using an ordinary compass. Fig. 1A.

The Electro-Magnet

We do not have to depend upon a magnet alone to produce these magnetic lines of force. If we were to wind a coil of wire around a soft iron nail, and then connect

The diagrams at the right show different types of magnetic fields, simple electro-magnet, magnetic induction by plunging magnet into coil, and how alternating current changes from positive to negative in passing through a cycle.

the ends of the wire to a battery, our compass would soon show us that we had produced a magnetic field around the coil, and if we were to repeat our little experiment of the iron filings upon a piece of cardboard, we would find that the iron filings would arrange themselves in the same pattern that we had observed when using the bar magnet.

The result we have achieved then is this: when a current of electricity flows through a coil of wire, a magnetic field is built up around that coil. Here then is one important relationship between electricity and magnetism. Figure 1 shows how we connect our coil to the battery to produce the magnetic effect.

However, we can reconvert the magnetic field back into an electric current by winding another coil of wire around another nail and making the proper connections to a galvanometer (a delicate instrument for measuring the flow of electric currents) as shown in Fig. 2.

Here the student of radio can see how it is possible for an electric current to "jump" across space from one circuit to another. The battery connected to the coil wrapped

(Continued on page 441)

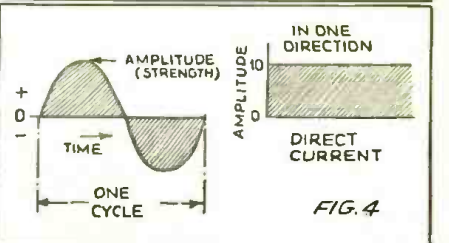
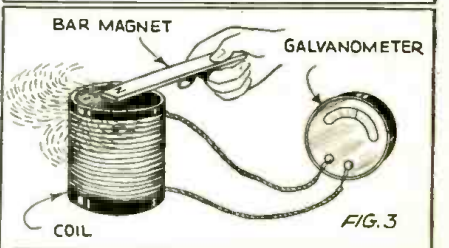
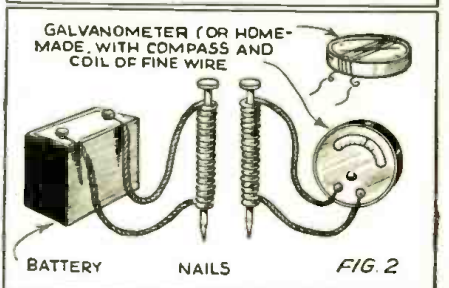
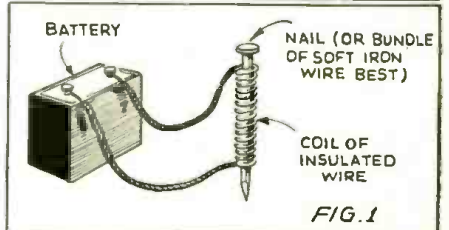
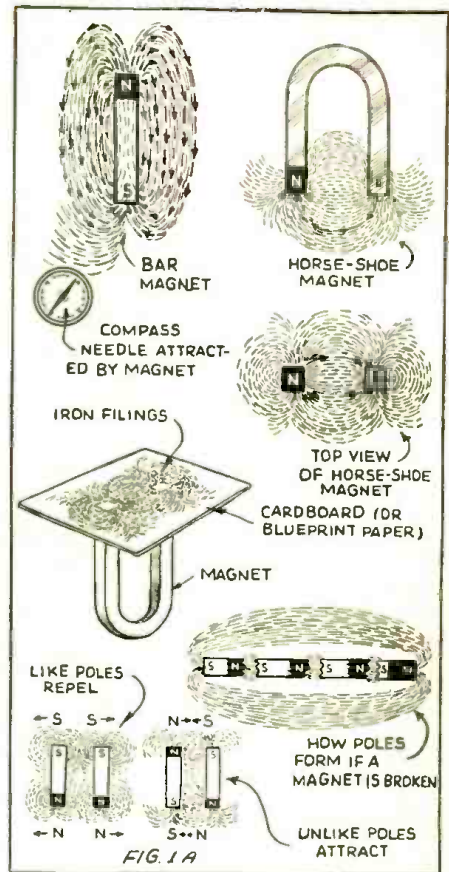

What Do YOU Think?



Warren H. Stark of Wauwatosa, Wisconsin, is a real "DXer". Look at those QSL cards!

The "International Round-Table" W. H. Stark—This Month's Prize Winner

Round-Table." It is composed of SWL's living in various spots around the globe. We have no dues whatsoever . . . just a friendly group of SWL's. We exchange DX dope, and discuss radio in general. At present we have members in England, Germany, Denmark, Norway, Malta, Australia, Tasmania, New Zealand, South Africa, Nigeria, Cuba, British Guiana, and, of course the United States. We would like to contact as many foreign countries as possible through correspondence, so if any readers care to join us, drop me a line, and I will be happy to furnish QRA's. Each member of the International Round-Table is an R99 fellow, who will reply promptly, and we are all acquainted with each other. So, what say, OM? Drop us a line, and we'll supply you all the QRA's you want, and if you have friends in countries outside of the above list, shoot 'em along.

That about winds up everything at this end. Enclosed is a picture of myself in the shack. The cards shown in the photo are only a few of the entire collection, but it'll give you an idea of what the shack really looks like. In closing, let me extend my congratulations to you on your fine magazine, and express my regrets that I didn't get it sooner. Will welcome letters from SWL's in the States and await those of DX SWL's.

WARREN H. STARK,
2117 North 62nd St.,
Wauwatosa, Wisconsin,

Editor,

Recently I picked up a copy of S. W. & T. (now R. & T.) and found it very interesting. You may count me in as a constant reader of your fine magazine in the future, and may expect letters from me occasionally.

I am an enthusiastic SWL, and am beginning my fourth year at it. My main hobby is collecting "wall-paper." (I have enough now to paper about three or four

rooms, Hi!) During the past three years I've QSL'ed and verified stations in 80 countries, the six continents (J2KG furnished Asia for HAC on 20 meter fone), and 42 states. I DX on 20 meter fone, and all bands for short wave broadcasters also. Latest cards received are CO2LY, COBZ, J2KG, HJ1ABE, HJ7ABB, HJ7ABD, VR6AY, and VP3THE.

Back in January, an English friend and I organized what we call the "International

Built 40 Sets from Our Designs

Editor,

In reading the September issue of SHORT WAVE & TELEVISION, I see you are changing the title of our "fine business" magazine.

I have but one thing to say as to that: *Keep It on the Same Standard*, and don't let down on such articles as "Short Wave League—On the Ham Bands; Radio Kinks; etc." I would like to see a list of stations which do not confirm reports. And, by all means, don't leave out our "What Do You Think?" column.

I talked with a young man a few days ago, who has built some forty sets from S. W. & T. and he tells me he has never found *one* that failed to meet all expectations.

For the benefit of the SWL's, I would like to say that I have received cards from three countries on the other side of the Globe: Australia, China and Hawaii, also from Cuba, and although these are only next-door neighbors to the HAMS, I prize them highly. I have heard from districts in the U.S. (except 4 and 6) and three districts in Canada. All SWL's total 30; all Hams total 21.

Not all Hams throw my cards in the basket, Hi!

I would like to hear from anyone interested in Radio, Hams, SWL's, and all.

Not all Hams are of the Naval Reserve; 90% are *Human*.

JAMES DAUGHARTY,
3038 Van Buren St.,
Chicago, Ill.

Editor,

As a reader of your magazine for the last three years, I have seen lots of photos of radio fans and their stations, both transmitting and receiving. I have admired these stations and wished that I could stop in one place long enough to rig myself up one, but unfortunately I travel a great deal so can only own a receiver and dare not nail veris on hotel walls. Therefore I cannot send you a very impressive picture of my equipment.

Radio has been a hobby of mine for the last 15 years; I lived in England till 1929, when I came to the States, so I have had a chance to "log" stations on both sides of the pond. All my receivers—before the one shown in the photo—were "home-made"; the first one using plug-in coils, the next one had an all-wave coil unit and switch, and that is what my latest set has.

I have heard nearly every country in the world and quite a lot of European amateurs on the 20 meter band, but I have never yet written for a veris as I am satisfied just to listen.

The receiver in the pic-

Charles Roberts, Pittsburgh, Pa., has "listened in" on both sides of the Atlantic.

Finds Our Station List Useful

ture is a Silvertone Precision model. Each month I find your short wave station list most useful.

CHARLES ROBERTS,
Penn Hall Hotel,
5700 Penn. Avenue,
Pittsburgh, Penna.

One Year's Subscription to RADIO & TELEVISION FREE

for Best "Listening Post" Photo
Closing date Nov. 15 for Jan. issue, etc. The editors will act as judges and their opinions will be final. In the event of a tie a subscription will be given to each contestant so tying.



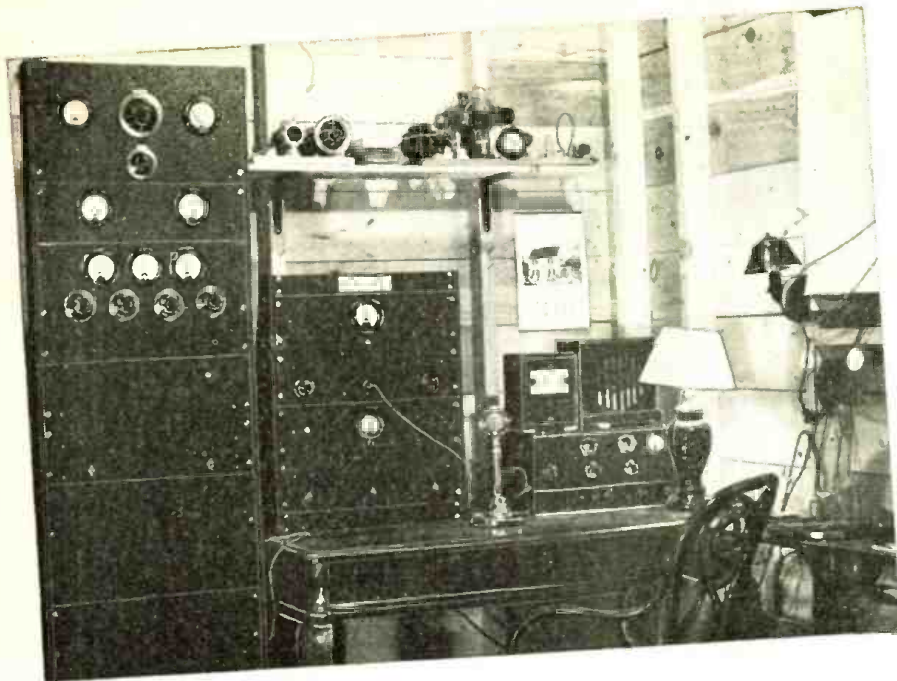

Roswell J. Parker

Fifth Silver Trophy

Awarded to

Roswell J. Parker

W8NNW, W8OTF, W8SAA

Scranton, Pa.

For Best HAM STATION Photo of the Month

● HEREWITH is a photo of my amateur radio station W8OTF in hopes that you may enter it in the contest for the best Ham Station photo of the month. This picture was taken last January and since then I have made a few changes. However, I will describe the "rig" as it was then.

On the left can be seen the six-foot relay rack which contains the 6L6 crystal oscillator, RK39 buffer, T55 driver for a pair of 852's in the final, running 750 watts input. The modulator, 203A's, also is in this rack. The two panel racks on the operating table contains the speech equipment. A crystal mike is fed to a 6J7, 6C5, pair of 6C5's and pair of 2A3's which drive the 203A's. The 2A3 drivers were recently put in in place of 6L6's. This unit was built from a circuit published in *SHORT WAVE CRAFT* some months ago as a 60-watt modulator and I modulated the T55 with it, running 132 watts input. Since then I added power and replaced the 6L6 with a 2A3.

On the right of the table can be seen the receiver. It is a Sargent superhet and on top of the receiver is a Triplett modulation monitor. Above the speech equipment on

the shelf is a pair of 852's being used as a five meter oscillator. This was later replaced with crystal control. The outfit pictured here is on 75 meter phone. The location of the transmitter is in a shack on top of a hill, twelve miles north of Scranton at a place called Waverly Heights. The antenna here is a single wire end-fed Hertz. Many a pleasant hour has been spent here and many a ham gathering has been enjoyed in these "wide open spaces."

Roswell J. Parker,
W8NNW-W8OTF-W8SAA,
1217 Linden Street,
Scranton, Pa.

Rules for Trophy Contestants

● WOULD you like to win one of these beautiful silver trophies? It is very easy to do so—simply send the Editors, a good, clear photograph of your Ham station. If your station photo is selected as the best of those submitted each month, you will be awarded one of these handsome silver trophies with your name engraved on it. The trophy stands nearly 12" high and

The trophy-winning Ham station of Roswell J. Parker, Scranton, Pa. A business-like station that steps out and goes places.



This beautiful silver trophy stands 11¾" high and is to be awarded monthly by RADIO & TELEVISION magazine for the best photo of a Ham station. The silver statue stands on a handsome bakelite base on which is a silver plate. The name of the winner will be engraved on this plate before the trophy is sent to him.

is a fine example of the silversmith's art. We are sure that every Ham in the country will be tickled with it, if he should win it. The silver trophy represents the spirit of victory and it was designed by one of the leading silversmiths. The name of the winner each month will be engraved on a silver plate mounted on the black bakelite pedestal before the trophy is sent to the successful contestant.

The next award will be announced in the December issue, and the closing date for that contest is October 10.

The judges of the contest will be the Editors of RADIO & TELEVISION. In the event of a tie, duplicate prizes shall be awarded to the contestants so tying.

GRA: POLSKIE RADIO - WARSAW - 5 MAZOWIECKA ST.

SPW
POLAND



THIS CONFIRMS YOUR REPORTS RECEIVED ON 12/21/38
SCHEDULES
ORG: 13635 KC POWER 10kw
TNX - QSL 73's

RADIOPHONE AND EXPERIMENTAL STATIONS

WMN, 14.59 mc., Lawrenceville, N. J., heard calling and contacting GBU, 12.290 mc., Rugby, England.

WMI, 6.47 mc., and 11.37 mc., Lorain, Ohio, give weather reports at 11 a.m. and 10 p.m.

KUN, 18.06 mc., Bolinas, heard at 9:20 p.m. contacting KQH, 14.92 mc., at Kahuku, Hawaii.

KHE, 17.98 mc., Kahuku, new Hawaiian radiophone, recently heard sending musical programs to the United States at 4:30 to 5 p.m.

KWU, 15.355 mc., Dixon, Calif. heard phoning JVD, 15.86 mc., Nazaki, Japan, at 8:18 p.m.

OPM, 10.14 mc., Leopoldville, Belgian Congo, Africa, heard near 7 a.m. contacting ORK, 10.33 mc., Belgium.

PDK, 10.41 mc., Kootwijk, Holland, heard recently carrying a Golden Jubilee Celebration program from Holland to America.

ZFB, 10.055 mc., Hamilton, Bermuda, heard contacting WOO, 9.87 mc., Lawrenceville, N. J., at 8:45 a.m. for exchange of traffic.

ZLT5, 11.0 mc., Wellington, New Zealand, heard phoning VLZ, 9.76 mc., at 11:30 p.m. and 2:30 a.m.

KAX, 19.98 mc., Manila, P. I., is heard on occasional Sundays relaying musical programs between 9 and 11 a.m.

VR6AY, 14.346 mc., Pitcairn Island, South Pacific, is heard usually around 4 a.m. Veri card in red and black on white background. The printed call "VR6A" in large red letters at top with "Y" added in red ink.

SUZ, 13.823 mc., SUV, 10.055 mc., and SUX, 7.86 mc., Cairo, Egypt, are heard on phone often. Reports should be sent to P.O. Box 795, Cairo.

VP3THE, in the jungles of British Guiana, November 14th, 1937 to January 15th, 1938, is now sending veri cards from New York for reports made during the time quoted. The writer heard VP3THE on November 20, 1937, and sent report to Isher-

ton, British Guiana, but it apparently came back to New York.

CUG2, 11.93 mc., CUI1, 11.925 mc., and CUA1, S. Miguel Azores, are commercial frequencies of Companhia Portuguesa Radio Marconi, and used for telephone and telegraph. CUG2 is used mostly, and being heard at 5 a.m. and 6 p.m. Reports should be sent to Rua de S. Juliao, 131, Lisbon, Portugal.

VRR4, 11.595 mc., Stonyhill, Jamaica, works with WNC, Hialeah, Florida, daily between 8 a.m. and 6 p.m.

**—BROADCASTERS—
THE FAR EAST**

Radio Burma, Rangoon, Burma, operates simultaneously on 6.007 and 3.488 mc., weekdays from 7:15 to 10 a.m. and 10 to 11:30 p.m.; Sundays 10 to 11:30 p.m. only, with 1 to 2 kw. power. Post and Telegraphs Department, Burma Independent Wireless Sub-Division, states that call signs have not been assigned, although request has been made on International Bureau, Bern, for allotment of call letters XYZ and XZZ.

VUD2, 9.59 mc., VUD2, 4.995 mc., VUD3, 9.59 mc., and VUD3, 15.16 mc., are broadcasting from New Delhi, India, daily 8:30 to 10:30 p.m.; 1:30 to 3:30 a.m. and 7:30 to 10:30 a.m.

VUB2, 9.55 mc. and VUB2, 4.905 mc., Bombay, 9:30 to 10:30 p.m.; 1 to 3:30 a.m. and 7 to 10:30 a.m.

VUM2, 4.95 mc., Madras, 7 to 9 a.m.
VUC2, 9.53 mc. and VUC2, 4.88 mc., 7:06 a.m. to 12:36 p.m. and 2:06 to 4:06 p.m.

All stations have 10 kw. power except VUD3 on 15.160 and 9.590 mc. which transmit with 5 kw. power. VUD3, 15.16 mc., is heard with R7 to 8 signal most evenings, and with sufficient power to enable one to hear the news in English beginning at 10:10 p.m. nightly. Programs prior to that time consist of Indian music and songs. Stations come on air with chimes and clock striking 7 a.m. and close with chimes and toll of clock for 9 a.m.

OWNED AND DIRECTED BY

KZRM

RADIO MANILA
Broadcast Manager

▲ Above—Veri card sent to Mr. Hinds by Station KZRM.
◀ Left—Beautiful Veri sent by S-W Station SPW, Poland.

Short Wave Listening Tips

J. B. L. Hinds

TAP, 9.465 mc., and TAQ, 15.195 mc., Ankara, Turkey, are reported calls and frequencies of new stations to be used for broadcasting service. Some claim they are on the air, but no definite advice yet received from station.

ZHO, 6.012 mc. and ZHP, 9.53 mc., Singapore, S.S., are the calls and frequencies given by the British Malaya Broadcasting Corporation, which also states that they work with 400 watts power only. A report from Australia says ZHP is working on 9.68 mc. between 6 and 9:40 a.m.

VK9MI, 11.71 and 6.01 mc., M. V. Kanimbla, 96 William Street, Melbourne, Australia, is normally on 6.01 mc. and is usually heard between 7 and 7:30 a.m. Signals: ships bells and siren; Opening: "Kanimbla Theme Song." Closing: "Sweet Dreams." Verification cards on all correct reports—and no stamps or I.R.C. expected.

VLR, 9.58 mc., Melbourne, Australia, wishes it known that they confirm all correct reports by letter. The opening and testing record is now "Waltzing Matilda" instead of the "Song of the Lyre Bird."

VK6ME, 9.59 mc., Perth, West Australia, although 11,625 miles from New York, is heard well with its power of 200 watts, unmodulated in the aerial. Its veri card adds to one's collection.

Radio Noumea, Noumea, New Caledonia, 6.122 mc., is being heard by a number of listeners between 2:30 and 3:30 a.m. Call letters are reported to be FK8AA. Open and close with "La Marseillaise" and heard to mention R.C.A. Victor.

Chinese station said to be XGJ and called "The Voice of China" reported heard at Hankow, opening at 7 a.m. on 11.68 mc.

XGX, 9.25 mc., Hankow, China, broadcasts to 10:30 a.m. daily with 150 watts power. Relays XGOW, now on 1010 kc. Address, 39 Huang Pli Road, S.A.D. No. 2, Hankow, China. Verifies by letter.

CQN, Macao, Portuguese China, 10.135 mc. where last heard, is not being heard at present. Has anyone any information?

"Radio Boy Landry," Saigon, Indo-China, transmits daily from 7:30 to 9:15 a.m. and 11:45 p.m. to 1 a.m. Station now on 6.21, 9.8 and 12. mc. Signal, 4 tone, 9 notes. Address 15-17 Place A Foray, Saigon. Programs in Chinese, Annamese and French.

YDC, 15.15 mc., Bandoeng, Java, heard best between 6 and 7 a.m.

YDB, Soerabaia, Java, now heard on 9.55 mc. instead of 9.61 mc. as reported.

YDA, Batavia, Java, has moved from 7.4 to 7.41 mc. and on the air from 7:30 p.m. to 2 a.m.

VPD2, 9.54 mc., Suva, Fiji Islands, advises they broadcast week days only from 5:30 to 7 a.m. Last letter to them brought reply from Amalgamated Wireless, P.O. Box 2516, Sydney, Australia.

JVH, 14.6 mc., Nazaki, Japan, heard often in early mornings and as late as 10 a.m., broadcasting musical numbers and news events in Japanese.

JZJ, 11.8 mc., and JZK, 15.16 mc., are carrying the Overseas programs from Tokyo daily, JZL, 17.785 mc., having been removed from service from 6 to 6:30 p.m. Both JZJ and JZK are heard with excellent signals. JZK, 15.16 mc., is now broadcasting a program from 8 to 8:30 p.m. in place of English broadcast of JZL above mentioned.

ZBW3, 9.535 mc., Hong Kong, China, heard by many listeners between 6 and 7 a.m.

JIB, 10.535 mc., Taihoku, Taiwan, heard between 5:30 and 6 a.m.

JDY, 9.925 mc., Dairen, Manchukuo, not heard regularly of late.

A new Japanese station is reported by a number of listeners on 9.69 mc., around 6 a.m.

ZMBJ, TSS Awatea, Union Steam Ship Company of New Zealand, operates on voice only on 4.42, 8.84 and 13.26 mc., and broadcasts music at no time. This information is for the benefit of radio writers and listeners who state or infer that ZMBJ is heard with musical programs. When heard, it is usually signing off after contacting either Sydney or Wellington. After each session of "scrambled" conversation they sign off in "plain English." ZMBJ uses 4.420 mc. mostly during their winter and spring months, the other two frequencies being used as occasion demands.

ZLT5, 12.295 mc., ZLT4, 11. and 10.98 mc., ZLT3, 8.9 mc. and ZLT2, 7.39 mc., are the calls and frequencies mostly used in radio phone service at Wellington, New Zealand, and which are in service during various seasons of the year.

The 10.98 and 7.39 mc. frequencies are the two in general use for day and night service to Australia and certain ships. Secrecy equipment is used on both frequencies.

ZLT1 to 6, inclusive, Wellington, New Zealand, with frequencies, 6.08, 9.54, 11.78, 15.28, 17.77 and 25.8 mc., are the calls and frequencies of the new transmitters to be installed.

AFRICA

ZRH, 9.523 and 6.007 mc., Roberts Heights, South Africa (near Pretoria) and ZRK, 9.606 and 6.0975 mc., Klipheuevel (near Capetown), transmit daily with 5 kw. power. ZRJ, 6.0975 and 6.007 mc., Maraisburg (near Johannesburg), daily with 200 watts power, will soon increase power to 500 watts. At present the 9.606 and 6.007 frequencies are best heard on the schedule from 11:45 p.m. to 12:45 a.m.

ZE, 5.8823 mc., Salisbury, and ZEB, 6.14777 mc., Bulawayo, South Rhodesia, are the latest reported calls and frequencies. These stations operate week days in early



Handsome Veri received by the author from Radio Martinique.

afternoon with 325 watts and on Sundays from 3:30 to 10 a.m. Address reports for both stations to General Post Office, P.O. Box 792, Salisbury, Southern Rhodesia, Africa.

CR6AA, Lobito, Angola, Portuguese West Africa, in late advice state they are broadcasting simultaneously on 9.666 and 7.177 mc.

ZNB, 5.9 mc., Mafeking, Bechuanaland Protectorate, South Africa, now broadcasts with 200 watts power on week days between 6 and 7 a.m. and 1 to 2:30 p.m. Sundays on same hours in afternoon only.

ZNC, ZND and ZNF, 5.9 mc., operate on radiophone in daytime with 40 watts power, and extremely doubtful if heard in America.

EUROPE

TPB3, 17.81 mc., TPB6, 15.13 mc., TPB7, 11.885 mc., TPB11, 9.55 mc., TPA2, 15.243 mc., TPA3, 11.9 mc., and TPA4, 11.718 mc., are now being used to broadcast French programs.

The Irish Free State, through its Minister for Posts and Telegraph, informs the writer that arrangements for the erection of an experimental short wave broadcasting station are being expedited as much as possible, but it is not expected that it will be ready to commence transmission until towards the end of this year or early next year. The date of opening of station will be announced in due course. The following frequencies have been assigned:—6.19, 9.595, 11.74, 15.12 and 17.84 mc.

Radio Nacional, Salamanca or Burgos, Spain, advises station is on 1258 kc. or 238.5 meters. Although they verify reports on 10.370 mc., they state that the call is EHZ and that it relays Radio Nacional. They further state—

"The relay station at Tenerife is *El Tablero*, which is not a broadcasting station, but radio telephone. Therefore, Radio Nacional, when using this relay, may be said to be broadcasting on a short wave." You may, therefore, suit yourself as to what you have upon receipt of card. Other short wave stations listed on the following frequencies: 6.75, 7.006, 7.06, 7.246, 7.35, 7.5 mc. FET1, 7.006 mc., Valladolid, Spain; 7.203 mc., Radio Español, San Sebastian, Spain; 7.246 mc., Radio Español, Bilbao, Spain; FET5, 7.35 mc., Burgos, Spain. Another one, near 11. mc., carries same program daily at 10.37 mc.

EAR, 9.48 mc., Madrid, Spain, is heard regularly as the "Voice of Republic of Spain," although EAQ, 9.860 mc., is heard at times. Announcements now indicate that reports should be sent to P.O. Box 951, Madrid.

Radio Malaga, Malaga, Spain, 7.220 mc., on air 9 to 10 a.m. and 4 to 5:30 p.m. They broadcast over the 14.44 mc. frequency from 5:40 to 8:45 p.m. Interference usually

strong on both frequencies. Veri cards in red and blue.

ORK, 10.330 mc., Bruxelles, Belgium, does not appear to be on the air.

Switzerland now has a short wave broadcasting station and, therefore, will not be required to transmit its overseas programs over the League of Nations' transmitters. The new station is in charge of Director General of Posts and Telegraph, Radio Division, at Bern, who advises they are now on 9.535 mc. experimentally, except Sunday and Monday from 1 to 2 p.m. When heard by the writer they were broadcasting on 15.360 mc. from 6:45 to 7:45 p.m. and on 11.865 mc. from 8 to 9 p.m. They were announcing these facts in English and requesting reports. The Director General states they use no identification signal nor do they give call letters on broadcasts. While transmitting on 15.36 mc. they met some code interference but the 11.865 frequency was free from interference, notwithstanding the close proximity of W8XK on 11.87 mc. The new Swiss station employs 300 watts power at present.

PCJ, 9.59 mc., Hilversum, Holland, the "Happy Station" with Edward Startz as Chief Announcer at the helm, sure puts a signal into America on Sunday, Tuesday and Wednesday evenings, with that new antenna directed our way.

OLR2A, 6.01 mc., OLR2B, 6.03 mc., OLR4A, 11.84 mc., OLR4B, 11.76 mc., OLR5A, 15.23 mc., OLR5B, 15.32 mc., and OK1MPT, 5.145 mc., are carrying excellent broadcasts from Czechoslovakia. Veri cards forwarded promptly and of varied scenes.

OLR6A, 17.83 mc., OLR7A, 21.45 mc., OLR7B, 21.565 mc., and OLR7C, 21.64 mc., are new frequencies assigned to Czechoslovakia, and which may be heard at any time.

HVJ, 15.121 and 5.969 mc., Vatican City, have been silent for a time. Although many facilities have been assigned, the new facilities will not be brought into use until later.

TFJ, 12.235 mc., Reykjavik, Iceland, is maintaining the usual Sunday concert and program from 1:40 to 2:30 p.m., and is coming into the United States with good signal. The Iceland Broadcasting Service also operates the following transmitters in irregular service in radio telephone service: TFN, 17.89 mc., TFM, 15.74 mc., TFL, 13.965 mc., TFJ, 12.175 mc., TFK, 9.005 and 9.06 mc., and TFI, 5.058 mc. All reports should be addressed to P.O. Box 547.

SPW, 13.635 mc., and SPD, 11.535 mc., Warsaw, Poland, continue to be heard nightly with strong signals and excellent programs. Warsaw is now adding two new frequencies which are understood to be 15.12 and 11.88 mc. The writer recently
(Continued on page 424)

The Short Wave League



Hugo Gernsback, Executive Secretary

HONORARY MEMBERS

Dr. Lee de Forest
D. E. Replogle
John L. Reinartz

Manfred von Ardenne
E. T. Somerset
Hollis Baird

On the Ham Bands (with the Listening Post Observers)

Edited by
Elmer R. Fuller



Listening Post of Observer Edward G. Slaughter of Plainview, Texas.

QSL card of PAOAA of the Netherlands, printed through the courtesy of the author.

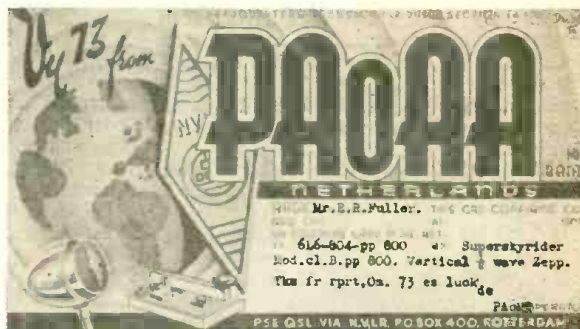

above distances from the observer.

The first report for the month of August comes from Observer Edward G. Slaughter of Texas. He reports the following on phone:—

Call	Freq.	R	S	Call	Freq.	R	S
CN1AF	14.300	5	7	VK4JP	14.270	5	8
CT1PR	14.285	5	8	VK3HG	14.020	5	6
KA1JM	14.050	5	7	VK4HN	14.295	5	8
KA3KK	14.310	5	7	VS6AG	14.280	5	7
PK2AY	14.080	5	7	ZS6DW	14.070	5	7
PK6XX	14.020	5	8	XU6TL	14.280	5	6
VK2NS	14.050	5	9	VK2ACL	17.060	5	9
VK2VV	14.140	5	7				

Please take special note of VK2ACL above, which was heard on the 40 meter band.

● ONE more month has gone by and here we are again, and the conditions are getting better and better, every day. During the month of August the stations and dx heard has *tripled* itself. The Africans, South Africans, Asiatics, and the Australians are once more putting their signals into these far-off lands of ours. They are coming in quite regularly. The ten meter band is also opening up, so some of the observers have reported during the past month.

Many requests for appointments have been received which could not be made, because of the large number of them. It is intended to appoint just one observer for each state. In this way it is hoped to keep the number of appointments low enough, so that every report sent in will be used in preparation of these articles. No one is expected to spend his time and postage sending in reports with the hope that they will be published. Any reports which comply with the rules outlined in last month's magazine, will be used.

All reports must be in by the fourth of the month. They should contain the station call, approximate frequency, readability, and sig-strength. LIST ONLY AMATEURS! Be sure to include only stations according to the distances outlined in the last issue. For the benefit of those who may not have read the last issue, the dx distances are as follows:— For 160 meters, 1000 miles; 80 meters, 1500 miles; for 10 and 20 meters, 2000 miles. Only send in reports on stations which are at least the

Observer Howard Kemp of Connecticut, sends in a fine report but it is impossible to put all of it into print. The total number of stations reported by Observer Kemp is *one hundred and fifty-three!* He certainly pulls them in on that new receiver up there. We have one here just like it, but we don't have any list of stations like that. Yours truly is picking out the best of the dx heard by this observer and listing them here as follows:—

Call	Freq.	R	S	Call	Freq.	R	S
VK4JP	14.100	3	5	VK3GI	14.060	3	5
VK6AP	14.100	3	5	K6MZQ	14.210	4	7
VK3BZ	14.198	3	5	K6FAB	14.256	4	7
VK2OJ	14.198	3	5	W1OXDA	14.250	4	7
VK2ADK	14.195	3	5	W1OXDA	14.300	4	7
VK3KX	14.120	3	4	VO1J	14.100	4	6
VK2AG	14.100	3	5	VO2Z	14.150	4	6

Among the other stations listed are those from the following countries:—

England, France, Scotland, Wales, Ireland, Northern Ireland, Belgium, Netherlands, Portugal, Haiti, Dominican Republic, Bermuda, Cuba, Guatemala, Puerto Rico, Virgin Islands, Honduras, Trinidad, Bahamas, Costa Rica, Mexico, Canal Zone, Venezuela, Colombian Republic, Argentina, Brazil, Chile, Ecuador, British Guiana, Jamaica, and Uruguay.

Just how Mr. Kemp logs all of these countries in one month is a mystery to me. This is as much as the average fan does in a year or two, to say nothing of doing it all in one month.

Stanley Clarke—Observer for Canada

Call	Freq.	R	S	Call	Freq.	R	S
PK6XX	14.300	5	8	G8WS	14.290	5	7
G2GK	14.105	2	4	CT1PR	14.275	5	7
G2HK	14.030	5	7	PA0MZ	14.140	5	8
HA8N	14.145	4	7	G8MO	14.100	5	8
F8UE	14.270	5	7	VK4HN	14.250	5	6
VK2TC	14.040	5	6	OA4R	14.130	5	7
VK2OQ	14.050	5	7	YV1AQ	14.000	5	8
G8CL	14.320	5	7				

Observer Clarke also includes in his report a section of cw (code) stations, but they are too numerous to put into print.

Charles H. Fuller—Observer for New York

Call	Freq.	R	S	Call	Freq.	R	S
LU8AB	18.810	5	6	F8NT	14.100	5	9
G5BJ	14.200	5	6	F3DI	14.100	5	9
XE2FK	14.150	5	8	LU8AC	14.075	5	8
NE1IK	14.175	4	8	G5ON	14.150	5	9
HC1JW	14.100	5	9	E16G	14.100	5	9

(Continued on page 442)



Listening Post of Observer Oscar Westman, of Capetown, South Africa

A Low-Loss Socket

First Prize

When building receivers for use on the ultra-high frequencies, it is somewhat advantageous to do away with the conventional tube socket in the R.F. stage to reduce the losses due to leakage across the socket's surface. A low-loss socket can be constructed, as shown in the sketch. A hole, which is of the same diameter as the tube's base, is drilled in a piece of bakelite or hard rubber and the tube is inserted in it (it may be neces-

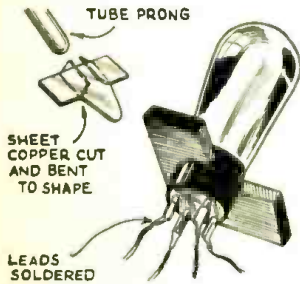

sary to insert a small wedge between the tube and the wall of the hole to insure a snug fit). The leads for connection to the pins of the tube are made from a piece of sheet copper, cut and bent to shape, as shown. The leads are soldered to the tabs on the ends of these pieces of sheet copper. When using this kink, care must be used in making certain that each lead goes to the right pin on the tube.—*Carl Johnk.*

Simulated I. C. W.

A signal that sounds like I.C.W. can be put on a C.W. carrier wave with little or no work or expense, if a code practice oscillator is at hand. The speaker connected to the oscillator is placed close to the microphone which is connected to the transmitter, and the tone picked up in this way is used to modulate the rig's carrier. If 100% modulation is used, the effect is the same as though I.C.W. were employed. This kink is especially valuable for 5 meter work, and the signal is all that anyone could desire.—*Richard J. Robinson.*

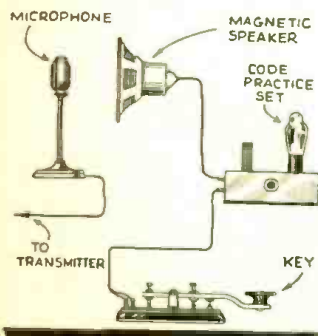

Radio Kinks

Each month the Editor will award a 2 year subscription for the best kink submitted. All other kinks published will be awarded eight months' subscription to RADIO & TELEVISION. Look over these kinks; they will give you some idea of what is wanted. Send a typewritten or ink description with sketch, of your favorite to the Kink Editor.

Antenna Coupling

A variable antenna coupling coil which may be operated from the front panel of the receiver is shown. The antenna coil consists of a 2-turn winding of No. 14 or No. 12 wire with inside diameter the same as that of the grid coil to which it is coupled. A 1/2" panel bearing and 1/4" bakelite shaft knob are the only other parts required. The No. 12 or 14 wire is sufficiently rigid to make the antenna coil self-supporting. A pair of flexible leads for connecting to the aerial and ground posts of the receiver should be soldered to the ends of this coil at the bakelite shaft, as shown.—*F. R. Hirshfeld.*

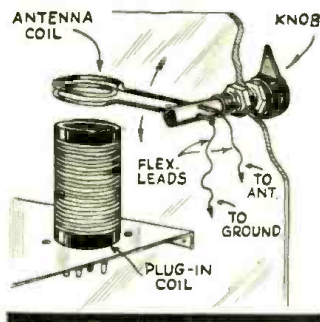

A Vibrator Power Supply

A versatile high voltage power supply may be constructed

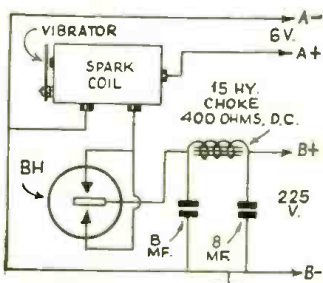

around an old Ford coil for operation from a 6-volt storage battery. As shown, the Ford coil is used as a vibrator to supply an interrupted current of stepped-up voltage to the BH rectifier tube which is connected to function as a half-wave rectifier. With the filter circuit shown, the output should be about 225 volts. It may be necessary to use an additional choke and condenser for further filtering in some circuits.—*Jerry's Radio Service.*

Wire Twisting

A handy wire twisting gadget can be made by filing a notch in the blade of a screw driver,

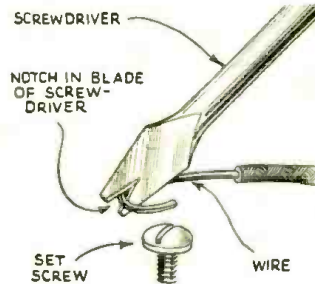

as shown. This tool may then be used for curling wire around a set screw or binding post in a tight place. The sketch is self-explanatory.—*Harold Bouman.*

U. H. F. Chokes

The ceramic core of burnt out metallized resistors may be used for winding ultra-high frequency choke coils for use on 5- and 10-meter equipment. Remove the solder from the ends of the core with a hot soldering iron. The metallized element will fall out with the core. Next, cut two strips of copper or brass 1/4" wide by 1 3/4" long and bend them, as shown in the drawing, leaving about a half inch on the shorter lug. Make the loop a trifle smaller than the diameter of the ceramic tube to insure a tight fit when they are both clamped together. Drill holes in these clamps, as shown, for a small nut and bolt. The choke coil winding may consist of about 32 turns of No. 28 D.C.C. wire; the 10-meter choke should have 65 turns of the same wire. The ends of the chokes are soldered to the lugs.—*Raymond T. Stephens.*

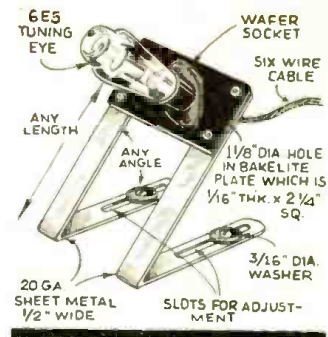
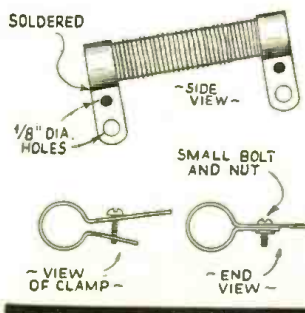

Mounting the "Magic Eye"

Here is a kink for mounting the 6E5 "Magic Eye" tube without going to the expense of purchasing the regular socket assembly usually used with this type of tube. I used an ordinary 6-prong wafer socket and, using two bolts, mounted it on a piece of fibre 2 1/4 inches square by 1/16-inch thick. The supporting brackets are cut out of 20-gauge sheet metal, 1/2-inch wide and as long as necessary. (Mine were 3 inches long.) The whole unit is made adjustable by slotting the holes in the brackets and by bending the brackets to any desired angle, so that the end of the tube will protrude through the panel when the socket is mounted on the receiver.—*Walter S. Cox.*

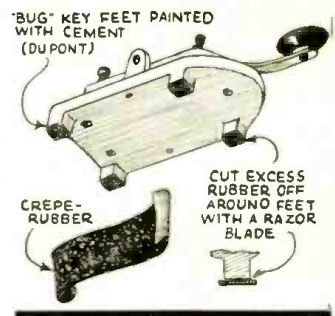

Skid-Proof Key

Those hams who are troubled with the key flying across the operating table whenever they try to use it, should find this kink particularly helpful. As is true of so many things, it is simplicity itself. Procure a piece of crepe-rubber pad from the nearest 5 and 10c store. It should be the type to keep small rugs from slipping. Cut strips from one of the pads, one for each foot of the key; cement the rubber to the feet of the keys with the crepe side out, using any water-proof cement. Allow the cement to harden for a few hours with the weight of the key pressing the pad securely to the feet. When the cement is dry, trim the edges of the rubber with a razor blade; then try sliding the key around—if you can.—*Sidney Rothman.*

Question Box

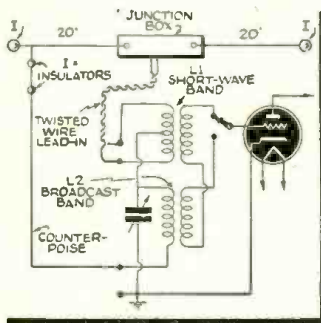

Noise-Reducing Antenna Hook-up. No. 1158.

Noise-Reducing Antenna

? Of late I have been troubled with noisy reception from my radio mostly in the broadcast band. Is there any system or antenna array that one can use to help try to reduce this annoyance?—F. K. Peters, Astoria, L. I.

A. A novel system of noise reduction has been designed in a new type of antenna recently brought out by a leading radio manufacturer. A sort of a bucking-out action on noise reduction is obtained by running a counterpoise parallel to the twisted transmission line as shown in the sketch. The antenna consists of a normal doublet fed at the center with a transmission line. At an approximate distance of 2 to 5 inches from the transmission line, a counterpoise runs parallel to the line down to the receiver. The length of this counterpoise should be one half the length of the transmission line plus 10 feet.

A doublet such as is shown in the diagram less the counterpoise has the properties of cancelling out noise picked-up by the feeder. However, when the noise-level is high, cancellation is not complete. Now the counterpoise comes into play by picking up noise in the vicinity of the feeder and impressing it back on the circuit, out of phase, so to speak, with the noise picked up by the feeder. Since these two wires are opposite they tend to cancel out and no noise reaches the receiver input coil.

The proper or correct phasing adjustment between the counterpoise and the transmission lead, is obtained by adjusting the trimmer condenser indicated in the diagram.

High Frequency Converter

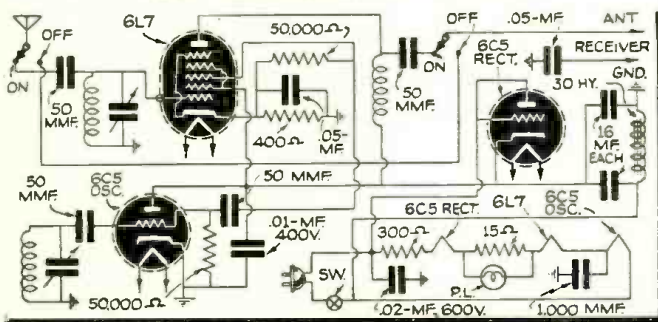

Circuit connections for a high frequency converter. No. 1159.

? Will you please publish a diagram of a short wave converter that will permit reception from about 12 to 5 meters, using a 6L7 and a 6C5? It should also contain its own rectifier unit.—Leonard Day, Peoria, Ill.

A. The circuit shown here will permit reception of signals from 12 to 5 meters if unit is attached to any receiver. This converter, likewise, can be used for the reception in picking up programs now being broadcast by many broadcast stations, which are putting out high-fidelity programs on the ultra-high frequencies. Thus the converter becomes a useful set accessory.

The 6L7 is utilized here as a mixer. A 6C5 is used as an oscillator and a second 6C5 as rectifier. The antenna feeds signals into the number 1 grid of the 6L7. The 6C5 oscillator injects a high frequency signal into the number 3 grid of the 6L7. The difference (or heterodyne) between this signal and the incoming signal introduces a low frequency beat which may be tuned in on any broadcast receiver. The broadcast receiver should be tuned to some frequency between 500 and 700 kc. A switching arrangement allows the converter to be cut out of the circuit, placing the broadcast receiver in normal operation whenever desired.

A fee of 25c (stamps, coin or money order) is charged for letters that are answered by mail. This fee includes only hand-drawn schematics. We cannot furnish full-size working drawings or picture layouts. Letters not accompanied by 25c will be answered on this page. Questions involving considerable research will be quoted upon request. Names and addresses should be clearly printed on each letter.

Beam-O-Scope Antenna

? A friend of mine recently purchased one of the new model G-E receivers. It is rather a unique set inasmuch as it has a switching arrangement for both outside antenna and for what is termed a "Beam-o-scope." What is this Beam-o-scope and how does it operate?—W. Schaaf, Boston, Mass.

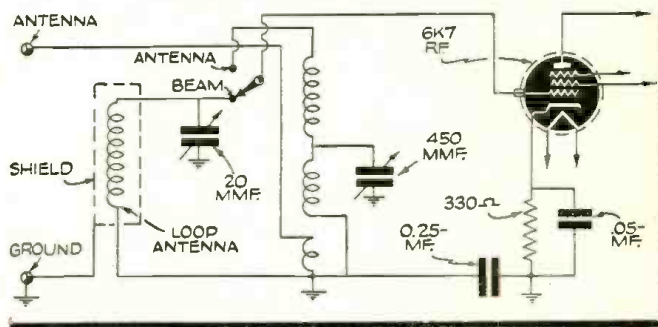

Hook-up of "Beam-O-Scope." No. 1160.

A. The Beam-o-scope consists of a tuned circuit completely enclosed by a special shield. This device possesses the properties of allowing only electro-magnetic fields to pass and excludes electrostatic fields. Most interference or noise is said to be of electrostatic nature and in the use of the shield this interference is claimed to be greatly reduced.

The Beam-o-scope itself is nothing more than a shielded loop antenna. It is housed inside the shield as shown. By a simple turn of the switch either Beam-o-scope or antenna reception may be had. When switched to the Beam-o-scope, the loop replaces the outside antenna coil and circuit and when the switch is thrown in the opposite direction the set is connected to the regular antenna. Alignment of the loop is made through the use of a small 20 mmf. tuning condenser. The loop does not track with the gang condenser. It measures approximately 12 inches wide by 24 inches in length.

When installed in the home, the loop is rotated and left in a position at minimum noise pickup. This adjustment is preferably made when tuned to a weak signal. Once the setting is made no readjustment is necessary.

Power Supply

? In one of your recent diagrams appearing in the QUESTION Box, you show a diagram of a power supply having a 300 volt transformer, yet its output is rated at the same voltage. It appears to me that where two choke coils are used there should be some voltage drop, which in my estimation should reduce the voltage output. Am I right in my assumption?—Peter Malarky, Tucson, Arizona.

A. In all power supply units we have condensers which play a part in filtering and when condensers are used as such the rectified voltage is boosted far beyond that of the rated transformer a.c. voltage, which in this case is 300 volts. The chokes do reduce the voltage, but the condenser input makes up for this loss. For instance, a specific example: a transformer having around 500 volts a.c. output each side of center tap when fed through a rectifier and condenser input filter delivered about 550 volts d.c. with a 150 mA. load; without the load the output was well over 650 volts.

World Short Wave Stations

Revised Monthly

Complete List of SW
Broadcast Stations

Reports on station changes are appreciated.

Mc.	Call	Station	Mc.	Call	Station	Mc.	Call	Station
31.600	WIXKA	BOSTON, MASS., 9.494 m., Addr. Westinghouse Co. Daily 6 am.-1 am., Sun. 8 am.-1 am. Relays WBZ.	17.810	TPB3	PARIS, FRANCE, 16.84 m. Addr. (See 15.245 mc.) 9.30-11 am.	15.260	GSI	DAVENTRY, ENG., 19.66 m., Addr. (See 17.79 mc.) 2-4.15 am., 12.20-4 pm., 9.20-11.25 pm.
31.600	WIXKB	SPRINGFIELD, MASS., 9.494 m., Addr. Westinghouse Co. Daily 6 am.-1 am., Sun. 8 am.-1 am. Relays WBZ.	17.800	TGWA	GUATEMALA CITY, GUAT., 16.84 m., Addr. Ministre De Fomento. Irregular.	15.250	WIXAL	BOSTON, MASS., 19.67 m., Addr. University Club. Sun. 10 am.-12 n.
31.600	W3XEY	BALTIMORE, MD., 9.494 m., Relays WFBR 4 pm.-12 m.	17.790	GSG	DAVENTRY, ENG., 16.86 m., Addr. B.B.C., London. 5.45 am.-12 n., 12.20-4 pm.	15.245	TPA2	PARIS, FRANCE, 19.68 m., Addr. 98 Bis. Blvd. Haussmann. "Paris Mondial" 6-11 am.
31.600	W2XDY	NEW YORK CITY, 9.494 m., Addr. Col. Broad. System, 485 Madison Ave. Daily 6-11 pm.; Sat. and Sun. 1.30-6, 7-10 pm.	17.785	JZL	TOKYO, JAPAN, 16.87 m. Irregular.	15.230	HS8PJ	BANGKOK, SIAM, 19.7 m. Irregular. Mon. 8-10 am.
31.600	W9XHW	MINNEAPOLIS, MINN., 9.494 m. Relays WCCO 9 am.-12 m.	17.780	W3XAL	BOUND BROOK, N. J., 16.87 m., Addr. Natl. Broad. Co., 9 am.-8 pm.	15.230	OLR5A	PRAGUE, CZECHOSLOVAKIA, 19.7 m., Addr. (See OLR4A, 11.84) Irreg. 7.55-10.55 pm.
31.600	W3XKA	PHILADELPHIA, PA., 9.494 m., Addr. NBC. Relays KYW 9 am.-10 pm.	17.770	PHI2	HUIZEN, HOLLAND, 16.88 m., Addr. (See PHI, 11.730 mc.) Daily 7.40-8.40 am. Tues. and Thurs., 7.25-8.40 am.	15.220	PCJ2	HUIZEN, HOLLAND, 19.71 m., Addr. N. V. Philips' Radio Hilversum. Tues. 2-3.30 am., Wed. 9.30-11.30 am. Daily exc. Sat. 6.15-6.45 pm., Sat. 7.15-7.45 pm.
31.600	W5XAU	OKLAHOMA CITY, 9.494 m., Sun 12 n.-1 pm., 6-7 pm. Irregular other times.	17.760	DJE	BERLIN, GERMANY, 16.89 m., Addr. Broadcasting House. 12.05-10 am.; also Sun. 11.10 am.-12.25 pm. Daily 4.50-10.45 pm.	15.210	WBXK	PITTSBURGH, PA., 19.72 m., Addr. (See 21.540 mc.) 8 am.-6 pm.
31.600	W4XCA	MEMPHIS, TENN., 9.494 m. Addr. Memphis Commercial Appeal. Relays WMC.	17.760	W2XE	NEW YORK, N. Y., 16.89 m., Addr. Col. Broad. System, 485 Madison Ave. Irregular.	15.200	DJB	BERLIN, GERMANY, 19.74 m., Addr. (See 15.280 mc.) 12.05-11 am., 4.50-10.45 pm. Also Sun. 11.10 am.-12.25 pm.
31.600	W8XAI	ROCHESTER, N. Y., 9.494 m., Addr. Stromberg Carlson Co. Relays WHAM 7.30-12.05 am.	17.755	ZBW5	HONGKONG, CHINA, 16.9 m., Addr. P.O. Box 200. 4-10 am. Irregular.	15.190	—	ROME, ITALY, 19.75 m. Relays ZRO "till 6 pm., irreg.
31.600	W8XWJ	DETROIT, MICH., 9.494 m., Addr. Evening News Ass'n. Relays WWJ 6-12.30 am., Sun. 8 am.-12 m.	End of Broadcast Band			15.190	—	LAHTI, FINLAND, 19.75 m. Addr. (See OFE, 9.5 mc.) Irregular.
31.600	W9XPD	ST. LOUIS, MO., 9.494 m., Addr. Pulitzer Pub. Co. Relays KSD.	17.310	W2XGB	HICKSVILLE, L. I., N. Y., 17.33 m., Addr. Press Wireless, Box 296. Tests 9.30-11.30 am. except Sat. and Sun.	15.190	ZBW4	HONGKONG, CHINA, 19.75 m., Addr. P. O. Box 200. Irregular. 11.30 pm. to 1.15 am., 3-10 am.
26.450	W9XA	KANSAS CITY, MO., 11.33 m., Addr. Commercial Radio Eqpt. Co. Testing after August 1st.	15.550	CO9XX	TUINICU, ORIENTE, CUBA, 19.29 m., Addr. Frank Jones, Central Tuinicu, Tuinicu, Santa Clara. Broadcasts irregularly evenings.	15.180	GSO	DAVENTRY, ENG., 19.76 m., Addr. (See 17.79 mc.) 4.15-6, 6.20-8.30 pm. 2-4.15 pm., 9 am.-12 n.
26.400	W9XAZ	MILWAUKEE, WIS., 11.36 m., Addr. The Journal Co. Relays WTMJ from 1 pm.	15.370	HAS3	BUDAPEST, HUNGARY, 19.52 m., Addr. Radiolabor, Gyali Ut 22. Sun. 9-10 am.	15.170	TGWA	GUATEMALA CITY, GUAT., 19.77 m., Addr. (See 17.8 mc.) Daily 10.45-11 am.; Sun. 10.45 am.-6 pm.
26.300	W2XJI	NEW YORK, N. Y., 11.4 m., Addr. Bamberger Broad. Service, 1440 Broadway. Relays WOR 8 am.-1 am.	15.360	DZG	ZEESEN, GERMANY, 19.53 m., Addr. Reichspostzentralamt. Tests irregularly.	15.160	XEWW	MEXICO CITY, MEXICO, 19.79 m., 12 n.-12 m., irregular.
26.100	W9XJL	SUPERIOR, WIS., 11.49 m. Relays WEBC daily.	15.360	—	BERNE, SWITZERLAND, 19.53 m. Irreg. 6.45-7.45 pm.	15.160	JZK	TOKYO, JAPAN, 19.79 m. 12.30-1.30 am., 2.30-4, 4.30-5.30, 8-8.30 pm.
26.050	W9XTC	MINNEAPOLIS, MINN., 11.51 m. Relays WCTN 9 am.-1 pm., 7 pm.-12 m.	19 Met. Broadcast Band			15.160	VUD3	DELHI, INDIA, 19.79 m., Addr. All India Radio. 1.30-3.30 am., 8.30-10.30 pm.
25.950	W6XKG	LOS ANGELES, CAL., 11.56 m., Addr. B. S. McGlashan, Wash. Blvd. at Oak St. Relays KGFJ 24 hours daily.	15.340	DJR	BERLIN, GERMANY, 19.56 m., Addr. Br'dcast'g House, 8-9 am., 4.50-10.45 pm.	15.155	SM5SX	STOCKHOLM, SWEDEN, 19.79 m., Daily 11 am.-5 pm., Sun. 9 am.-5 pm.
25.950	W9XUP	ST. PAUL, MINNESOTA, 11.56 m. Relays KSTP evenings.	15.330	W2XAD	SCHENECTADY, N. Y., 19.56 m., Addr. General Electric Co. Relays WGY, 12.15-6 pm.	15.150	YDC	BANDOENG, JAVA, 19.8 m., Addr. N. I. R. O. M. 6.7-30 pm., 10.30 pm.-2 am., Sat. 7.30 pm.-2 am., daily 5.30-10.30 am.
21.550	GST	DAVENTRY, ENG., 13.92 m., Addr. (B.B.C., London) Irregular at present.	15.320	OLR5B	PRAGUE, CZECHOSLOVAKIA, 19.58 m., Addr. (See 11.840 mc.) Sun., Wed., Sat. 5-5.10 pm.; Mon., Tues., Thurs., Fri. 6.55-9.55 pm.	15.140	G5F	DAVENTRY, ENG., 19.82 m., Addr. (See 17.79 mc.) 5.45 am.-12 n.
21.540	W8XK	PITTSBURGH, PA., 13.93 m., Addr. Grant Bldg. Relays KDKA 6.45-9 am. Also Sunday, 6 pm.	15.310	GSP	DAVENTRY, ENG., 19.6 m., Addr. (See 17.79 mc.) 9 am.-12 m., 12.20-4, 4.15-6.00, 6.20-8.30 pm.	15.130	TPB6	PARIS, FRANCE, 19.83 m., Addr. "Paris Mondial," 98 Bis Blvd. Haussmann. Irregular.
21.530	GSJ	DAVENTRY, ENG., 13.93 m., Addr. (See 21.550 mc.) 5.45-8.50 am.	15.310	GSP	DAVENTRY, ENG., 19.6 m., Addr. (See 17.79 mc.) 9 am.-12 m., 12.20-4, 4.15-6.00, 6.20-8.30 pm.	15.130	WIXAL	BOSTON, MASS., 19.83 m., Addr. World-Wide B'cast'g Foundation. University Club. 10-11 am., Mon.-Fri.
21.520	W2XE	NEW YORK CITY, 13.94 m., Addr. Col. Broad. Syst., 485 Madison Ave. Daily exc. Sat. and Sun. 7.30-10 am. Sat. and Sun. 8 am.-1 pm.	15.300	—	ROME, ITALY, 19.61 m., Addr. (See 2RO, 11.81 mc.) Relays ZRO to 9 pm. irregularly.	15.120	HVJ	VATICAN CITY, 19.83 m., 10.30-10.45 am., Tues., Wed. & Thurs.
21.500	W2XAD	SCHENECTADY, N. Y., 13.95 m., General Electric Co., 8 am.-12 n.	15.290	LRU	BUENOS AIRES, ARG., 19.62 m., Addr. El Mundo. Relays LRI, 7-9 am.	15.110	DJL	BERLIN, GERMANY, 19.85 m., Addr. (See 15.280 mc.) 12 m.-2, 8-9 am., 10.40 am.-4.25 pm., also Sun. 6-8 am.
21.470	GSH	DAVENTRY, ENG., 13.97 m. (See 21.550 mc.) 5.45 am.-12 n.	15.280	H13X	CIUDAD TRUJILLO, D. R., 19.63 m. Relays IIX Sun. 7.40-10.40 am. Weekdays 12.10-1.10 pm.	14.940	PSE	RIO DE JANEIRO, BRAZIL, 20.08 m., Broadcasts Wed. 3.45-4.15 pm.
21.450	DJS	BERLIN, GERMANY, 13.99 m., Addr., Broadcasting House. 12.05-11 am.	15.280	DJQ	BERLIN, GERMANY, 19.63 m., Addr. Broadcasting House. 12.05-10 am., 4.50-10.45 pm. Also Sun. 11.10 am.-12.25 pm.	14.600	JVH	NAZAKI, JAPAN, 20.55 m. Broadcasts irregularly 5-11.30 pm. Works Europe 4-8 am.
19.020	HS8PJ	BANGKOK, SIAM, 15.77 m. Mondays 8-10 am.	15.270	W2XE	NEW YORK CITY, 19.65 m., Addr. (See 21.520 mc.) Daily except Sat. and Sun. 1-6 pm., Sat. and Sun. 2.30-6 pm.	14.535	HBJ	GENEVA, SWITZERLAND, 20.64 m., Addr. Radio Nations. Broadcasts Sun. 1.45-2.30 pm., Mon. 7-8.30 pm.
18.480	HBH	GENEVA, SWITZERLAND, 16.23 m., Addr. Radio Nations. Sun., 10.45-11.30 am.	End of Broadcast Band			<i>(Continued on page 410)</i>		
16 Met. Broadcast Band								
17.810	—	ROME, ITALY, 16.84 m., Addr. (See 2RO, 11.81 mc.) Relays ZRO to 6 pm. irregularly.						

All Schedules Eastern Standard Time

New Television Receiver

● A LOW-PRICED television kit with which an up-to-date, practical sight receiver can be constructed was recently demonstrated by the Garod Radio Corporation. The set, in "knockdown" form, is now available through the Wholesale Radio Service Co. It is designed particularly for the novice and beginner and provides fundamental knowledge to the amateur and experimenter desiring to pursue television as a hobby or career.

(Continued on page 431)

Two views of new 17 tube Television receiver—with and without cabinet.

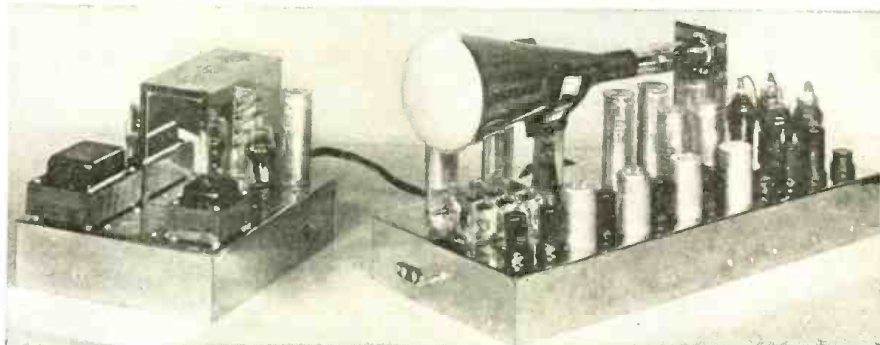

New Medium High Power Transmitter

● THE exciter unit employs a standard system of band switching to provide highest circuit efficiency with maximum flexibility. Coils for five bands (1.5 to 30 mc.) are changed by means of Isolantite switches. A 6L6 in a conventional oscillator circuit drives one 807 or RK39 as a buffer amplifier or frequency multiplier. A variable coupling control assures proper excitation to all tubes over a wide range of frequencies. Both stages are individually metered. Positions for four crystal holders are provided with front panel controlled selector switch.

In the intermediate-power amplifier an RK47 beam power tube furnishes ample excitation to a pair of T55's or RK51's in push-pull as the final modulated amplifier. Since this unit has been designed to operate with more than ample excitation on all frequencies, it is necessary to adjust the excitation control accordingly, for on the

lower frequencies, the RK47 is capable of over-driving the final amplifier. The final stage can be fully excited under all operating conditions. Both the intermediate and power amplifier stages employ plug-in coil forms of low-loss design. The final amplifier is designed to run at an input of from 400 to 450 watts on telephone and telegraph. A circuit efficiency of 75% on the three lower frequency bands is obtained, while on 10 and 20 meters, 65 to 70% efficiency is had. A low impedance swinging link is provided in the final amplifier tank circuit.

The 2B speech amplifier consists of a 6J7 pentode, resistance-coupled to a 6N7 that also functions as an electronic mixer. This stage is transformer coupled to a pair of 6C5's which drive a pair of 2A's in push-pull. Two input circuits are provided to accommodate either a crystal microphone or crystal

(Continued on page 431)

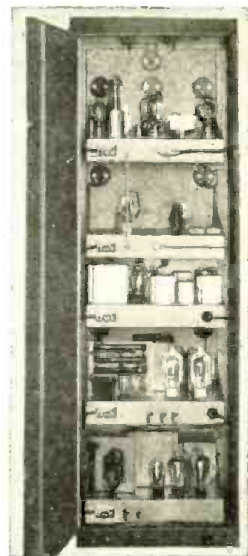
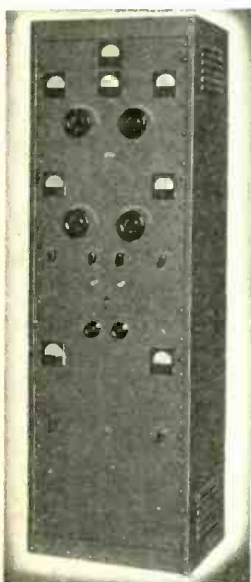

A 5-Band One-Tube Preselector



Preselector in case.

● THE demand for a simple, effective band-switch preselector for present day short-wave reception is increasing as new amateur stations come on the air. Radio amateurs are aware of the value of a good preselector in pulling through weak, "far-off" signals that are being blocked by strong "local" stations.

A stable regenerative circuit was chosen for maximum radio-frequency gain. The tube used, the new type 1851,

was designed with a high amplification factor and gives excellent results in high frequency operation. The 6K7, another metal-type high gain amplifier pentode tube, also works satisfactorily in the preselector.

The new Browning BL-5H r.f. tuner proved ideal for our requirements. It comes completely assembled with five coils, trimmer, condensers and band-switch, thus eliminating the use of plug-in coils or the task of constructing your own coil arrangement. The Browning tuning assembly has a two-deck switch, enabling one to select any of the 5 short-wave bands at will by means of a knob on the front panel. It is fundamentally designed to cover the 10,

20, 40, 80, and 160 meter amateur bands. The 35 mmf. variable tuning condensers and the grid condenser and resistor are common for all bands.

The preselector makes possible 10 meter operation of super-heterodynes having a wide 20 meter band, provided the intermediate frequency (I.F.) is not higher than 500kc. (General coverage receivers with any I.F. may be employed, utilizing the principle outlined here.) This may be accomplished by connecting the output of the pre-

(Continued on page 426)

William Filler, W2AOQ

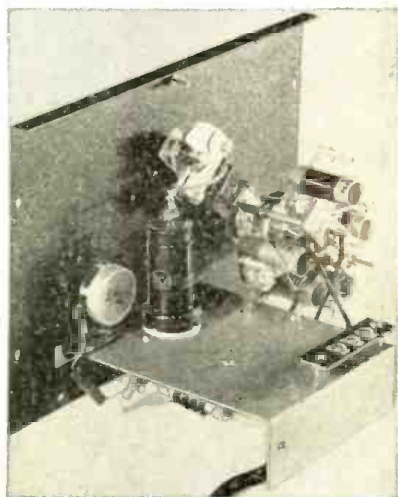

Rear View, showing Browning band-switch and coil assembly.

Mc.	Call	Mc.	Call	Mc.	Call
14.440	—	RADIO MALAGA, SPAIN, 20.78 m. Relays Salamanca 8.15-8.45 pm. Sometimes 2-4 pm.	11.790	WIXAL	BOSTON, MASS., 25.45 m., Addr. (See 15.250 mc.) Daily 4.55-6.30 pm., Tues., Thur., 4.40-6.30 pm., Sat. 1.45-6 pm., Sun. 5-6.30 pm.
14.166	PIIJ	DORDRECHT, HOLLAND, 21.15 m., Addr. (See 7.088 mc.) Sat. 12 n.-12.30 pm.	11.780	HP5G	PANAMA CITY, PAN., 25.47 m., Addr. Box 1121. Heard till 12 m.
14.004	EA9AH	TETUAN, SPANISH MOROCCO, 21.4 m. Apartado 124. News at 4.30 and 7.15 pm. Relays Salamanca from 5.40 pm.	11.780	OFD	LAHTI, FINLAND, 25.47 m. Addr. (See OFE, 9.5 mc.) 1.05 am.-2.05 pm.
13.635	SPW	WARSAW, POLAND, 22 m. Daily 6-8 pm. Sat. & Sun. 6-9 pm.	11.770	DJD	BERLIN, GERMANY, 25.49 m., Addr. (See 15.280 mc.) 10.40 am.-4.30 pm., 4.50-11 pm.
12.862	W9XDH	ELGIN, ILL., 23.32 m. Press Wireless, Tests 2-5 pm.	11.760	TGWA	GUATEMALA CITY, GUAT., 25.51 m. (See 17.8 mc.) Irregular 10-11.30 pm. Sun. 6-11.30 pm., irregular.
12.235	TFJ	REYKJAVIK, ICELAND, 24.52 m. Works Europe mornings. Broadcasts Sun. 1.40-2.30 pm.	11.760	XETA	MONTEREY, MEX. 25.51 m., Addr. Box 203. Relays XET, 1-3.30 pm. and evenings.
12.200	—	TRUJILLO, PERU, 24.58 m., "Rancho Grande." Address Hacienda Chiclin. Irregular.	11.760	OLR4B	PRAGUE, CZECHOSLOVAKIA, 25.51 m., Addr. (See 11.840 mc.) Irregular.
12.060	RNE	MOSCOW, U.S.S.R., 24.88 m. Daily 6-7 am., 12.15-1 pm., 3-6, 8-9.15, 10-11 pm., also Sun. 6 am.-1 pm.	11.750	GSD	DAVENTRY, ENG., 25.53 m., Addr. B.B.C., London. 2-4.15 am., 12.20-6.00 pm., 6.20-8.30, 9.20-11.25 pm.
11.970	H12X	CIUDAD TRUJILLO, D. R., 25.07 m., Addr. La Voz de Hispaniola. Relays HIX Tue. and Fri. 8.10-10.10 pm.	11.740	COCX	HAVANA, CUBA, 25.55 m. P. O. Box 32. Daily 8 am.-1 am. Sun. 8 am.-12 m. Relays CMX.
25 Met. Broadcast Band					
11.920	T12XD	SAN JOSE, COSTA RICA, 25.19 m. La Voz del Pilot. Apartado 1729. 11 am.-2 pm., 5-11 pm., exc. Sun.	11.740	HVJ	VATICAN CITY, 25.55 m. Testing irregular.
11.910	CD1190	VALDIVIA, CHILE, 25.2 m., P. O. Box 642. Relays CB89 10 am.-1 pm., 11 am.-10 pm.	11.730	PHI	HUIZEN, HOLLAND, 25.57 m., Addr. N. V. Philips' Radio.
11.900	—	HANOI, FRENCH INDO-CHINA, 25.21 m. "Radio Hanoi", Addr. Radio Club de l'Indochine. 12 m.-2 am., 6-10 am.	11.730	WIXAL	BOSTON, MASS., 25.57 m., Addr. World-Wide Broadcast'g Foundation, University Club. Daily exc. Sat. and Sun. 9-11 pm.
11.900	XEWI	MEXICO CITY, MEXICO, 25.21 m., Addr. P. O. Box 2874. Mon., Wed., Fri. 3-4 pm., 9 pm.-12 m. Tues. and Thur. 7.30 pm.-12 m., Sat. 9 pm.-12 m.	11.720	CJRX	WINNIPEG, CANADA, 25.6 m., Addr. James Richardson & Sons Ltd. Daily 6 pm.-12 m., Sun. 5-10 pm.
11.895	HP5G	PANAMA CITY, PAN., 25.22 m., Addr. Box 1121. 9.30 am.-1 pm., 6-11 pm.	11.718	CR7BH	LAURENÇO MARQUES, PORTUGUESE E. AFRICA, 25.6 m. Daily 12.05-1, 4.30-6.30, 9.30-11 am., 12.05-4 pm., Sun. 5-7 am., 10 am.-2 pm.
11.885	TPA3	PARIS, FRANCE, 25.24 m., Addr. (See 15.245 mc.) 2-5 am., 11.15 am.-6 pm.	11.715	TPA4	PARIS, FRANCE, 25.61 m., (See 15.245 mc.) 7-9.15 pm., 9.30 pm.-12 m.
11.885	TPB7	PARIS, FRANCE, 25.24 m. (See 15.245 mc.) 7-9.15, 9.30 pm.-12 m.	11.710	SBP	MOTALA, SWEDEN, 25.63 m., 1.20-2.05, 6-9 am., 11 am.-1 pm., Sat. 1.20-2 am., 6 am.-1.30 pm., Sun. 3 am.-1.30 pm. Wed. and Sat. 8-9 pm.
11.870	W8XK	PITTSBURGH, PA., 25.26 m., Addr. (See 21.540 mc.) 6-8.45 pm.	11.710	YSM	SAN SALVADOR, EL SALVADOR, 25.63 m., Addr. (See 7.894 mc.) Irregular 1.30-2.30 pm.
11.865	—	BERNE, SWITZERLAND, 25.28 m. Irreg. 8-9 pm.	11.710	—	SAIGON, FRENCH INDO-CHINA, 25.63 m., Addr. Boy-Landry, 17 Place A Foray, 6-9.15 am.
11.860	GSE	DAVENTRY, ENG., 25.29 m., Addr. (See 11.75 mc.) 2-4.15 am.	11.700	HP5A	PANAMA CITY, PAN., 25.65 m., Addr. Radio Teatro, Apartado 954. 10 am.-10 pm.
11.855	DJP	BERLIN, GERMANY, 25.31 m., Addr. (See 15.280 mc.) Irregular 11.35 am.-4, 7-10.45 pm.	11.700	CB1170	SANTIAGO, CHILE, 25.65 m. Addr. P.O. Box 706. Relays CB89 6 pm.-12 m.
11.840	KZRM	MANILA, P. I., 25.35 m. Addr. Erlanger & Gallingier, Box 283. 9 pm.-10 am. Irregular.	—End of Broadcast Band—		
11.840	CSW	LISBON, PORT., 25.35 m. Nat'l Broad. Station. 11.30 am.-1.30 pm. Irregular.	11.676	IQY	ROME, ITALY, 25.7 m. Relays 2RO 1.35-2.25, 6-9 pm.
11.840	OLR4A	PRAGUE, CZECHOSLOVAKIA, 25.34 m., Addr. Czech Shortwave Sta., Praha XII, Fochova 16. Daily 12.55-4.30 pm. Mon., Tues., Thurs., Fri. 7.55-10.55 pm., Sun. 5.55-8.55 pm.	11.530	SPD	WARSAW, POLAND, 26 m., Addr. 5 Mazowiecka St. 6-9 pm.
11.830	W9XAA	CHICAGO, ILL., 25.36 m., Addr. Chicago Federation of Labor. Irregular 7 am.-6 pm.	11.402	HBO	GENEVA, SWITZERLAND, 26.31 m., Addr. Radio Nations. Sun. 7-7.45 pm., Mon. 1-1.15 am., 7-8.30 pm.
11.830	W2XE	NEW YORK CITY, 25.36 m., Addr. Col. Broad. System, 485 Madison Av., N.Y.C. 6.30-11 pm.	11.040	CSW7	LISBON, PORTUGAL, 27.17 m., Addr. Nat. Broad. Sta. 1.30-5 pm.
11.826	XEBR	HERMOSILLA, SON., MEX., 25.37 m., Addr. Box 68. Relays XEBH. 1-4 pm., 9 pm.-12 m.	11.000	PLP	BANDOENG, JAVA, 27.27 m. Relays YDB, 6-7.30 pm., 10.30 pm.-2 am., 4.30-10.30 or 11 am. Sat. until 11.30 am.
11.820	G5N	DAVENTRY, ENG., 25.38 m., Addr. (See 11.75 mc.) Irregular.	10.960	—	TANANARIVE, MADAGASCAR, 27.36 m., Addr. (See 9.38 mc.) 12.30-4.5, 3.30-4.30, 10-11 am. Sun. 2.30-4 am.
11.810	ZRO	ROME, ITALY, 25.4 m., Addr. E.I.A.R., Via Montello 5. Daily 4.40-8.45 am., 10 am.-9 pm.	10.670	CEC	SANTIAGO, CHILE, 28.12 m. Irregular.
11.805	COGF	MATANZAS, CUBA, 25.41 m., Addr. Gen. Betancourt 51. Relays CMGF. 2-3, 4-5, 6-11 pm.	10.660	JVN	NAZAKI, JAPAN, 28.14 m. Broadcasts daily 2-8 am. Works Europe irregularly at other times.
11.805	OZG	SKAMLEBOAOK, DENMARK, 25.41 m. Addr. Statsradiofonien. Irreg.	10.600	ZIK2	BELIZE, BRIT. HONDURAS, 28.25 m., Tue., Thurs., Sat. 1.30-2, 8.30-9 pm.
11.800	JZJ	TOKYO, JAPAN, 25.42 m., Addr. Broadcasting Co. of Japan, Overseas Division. 7-7.30, 8-9.30 am., 2.30-4, 4.30-5.30 pm.	10.535	JIB	TAIHOKE, TAIWAN, 28.48 m. Works Japan around 6.25 am. Broadcasts, relaying JFAK 9.05-10 am., 1-2.30 am. Sun. to 10.15 am.
11.795	DJO	BERLIN, GERMANY, 25.43 m., Addr. (See 15.280 mc.) 7-10.45 pm.	10.370	EAJ43	TENERIFFE, CANARY ISLANDS, 28.93 m. Relays Salamanca, Spain, 2-4, 5-9.45 pm.
10.330	ORK	RUYSSELEDE, BELGIUM, 29.04 m. Broadcasts 1.30-3 pm. Works OPM 1-3 am., 3-5 pm.	10.350	LSX	BUENOS AIRES, ARG., 28.98 m., Addr. Transradio International. Tests irregularly.
10.290	DZC	ZEESEN, GERMANY, 29.16 m., Addr. (See 15.360 mc.) Irregular.			
10.260	PMN	BANDOENG, JAVA, 29.24 m. Relays YDB 6-7.30 pm., 10.30 pm.-2 am., 4.30-10.30 or 11 am., Sat. to 11.30 am.			
10.220	PSH	RIO DE JANEIRO, BRAZIL, 29.35 m., Addr. Box 709. Broadcasts 6-9 pm.			
10.042	DZB	ZEESEN, GERMANY, 29.87 m., Addr. Reichspostzentramt. Irregular.			
9.980	COBG	HAVANA, CUBA, 30.04 m., Addr. P. O. Box 132. Relays CMBC 6.55 am.-12 m.			
9.940	JDY	DAIREN, MANCHUKUO, 30.18 m. Relays JQAK daily 7-8 am. Works Tokyo occasionally in early am.			
9.860	EAQ	MADRID, SPAIN, 30.43 m., Addr. Post Office Box 951. 7.30-8, 8.40-9 pm.			
9.833	COCM	HAVANA, CUBA, 30.51 m. Addr. Transradio Columbia, P. O. Box 33. 8-1 am. Relays CMCM.			
9.830	IRF	ROME, ITALY, 30.52 m. Works Egypt afternoons. Relays 2RO, 6-9 pm.			
9.760	—	SAIGON, INDO-CHINA, 30.72 m., Addr. 17, Place A. Foray. "Radio Boy-Landry." Heard 6-9.15 am.			
9.740	COCQ	HAVANA, CUBA, 30.85 m. Addr. 25 No. 445, Vedado, Havana, 7-1 am. Sun. 6.55 am.-12.30 pm.			
9.710	CSW5	LISBON, PORTUGAL, 30.87 m., Addr. Nat. Broad. Sta. 5-8 pm.			
9.700	—	FORT DE FRANCE, MARTINIQUE, 30.9 m., Addr. P. O. Box 136. 11.30 am.-12.30 pm., 6.15-7.50 pm.			
9.690	T14NRH	HEREDIA, COSTA RICA, 30.94 m., Addr. Amando C. Marin, Apartado 40. Sun. 7-8 am. Tues., Thurs., Sat. 9-10 pm.			
9.685	TGWA	GUATEMALA CITY, GUAT., 30.96 m. Daily 10-11.30 pm.; Sun. 6-11.30 pm.			
9.680	ZHP	SINGAPORE, MALAYA, 30.98 m. Sun. 5.40-9.40 am., Wed. 12.40-1.40 am., Mon.-Fri. 4.40-9.40 am., Sat. 12.25-1.40 am., 4.40-9.40 am., 10.40 pm.-1.10 am. (Sun.).			
9.675	DZA	ZEESEN, GERMANY, 31.01 m., Addr. (See 10.042 mc.) Irregular.			
9.670	—	ROME, ITALY, 31.03 m. Relays 2RO 6-9 pm. Irregular.			
9.660	LRX	BUENOS AIRES, ARG., 31.06 m., Addr. El Mundo. Relays LRI, 9.30 am.-11 pm.			
9.650	CS2WA	LISBON, PORTUGAL, 31.09 m., Addr. Radio Colonial. Tues., Thurs. and Sat. 3.30-6 pm.			
9.645	HH3W	PORT-AU-PRINCE, HAITI, 31.1 m., Addr. P. O. Box A117. 1-2, 7-8 pm.			
9.640	CXA8	COLONIA, URUGUAY, 31.12 m., Addr. Belgrano 1841, Buenos Aires, Argentina. Relays LR3, Buenos Aires 6 am.-10 pm.			
9.635	ZRO	ROME, ITALY, 31.13 m., Addr. (See 11.810 mc.) Off the air at present.			
9.630	HJ7ABD	BUCARAMANGA, COL., 31.14 m. 10 am.-12 n., 4-11 pm.			
9.625	JFO	TAIHOKE, TAIWAN, 31.16 m. Relays JFAK irreg. 4-10 am.			
9.616	HJ1ABP	CARTAGENA, COL., 31.20 m., Addr. P. O. Box 37. 11 am.-1 pm., 5-11 pm., Sun. 10 am.-1 pm., 3-6 pm.			
9.615	ZRK	KLIPHEUVAL, SOUTH AFRICA, 31.2 m., Addr. P. O. Box 4559, Johannesburg. Daily, exc. Sat. 11.45 pm.-12.50 am. Daily exc. Sun. 3.20-7.20, 9-11.45 am. Sun. 3.30-4.30 or 4-5, 5.30-7, 9-11.45 am.			
9.607	HP5J	PANAMA CITY, PANAMA, 31.23 m. Addr. Apartado 867. 12 n. to 1.30 pm., 6-10.30 pm.			
31 Met. Broadcast Band					
9.600	RAN	MOSCOW, U.S.S.R., 31.25 m. 7-9.15 pm.			
9.595	H8L	GENEVA, SWITZERLAND, 31.27 m., Addr. Radio Nations. Irregular.			

(Continued on page 412)

All Schedules Eastern Standard Time

A Versatile

Cathode-Ray Monitor



For the HAM Station



A front view of the cathode-ray monitor.

This monitor or oscilloscope is a very handy all-around instrument and the "ham" will find it tremendously useful. It can be used to check up the degree of modulation; another of its uses is to check the characteristics of a transmitter at the station's receiver. The cost of building the apparatus is nominal, considering its many applications.

C. Walter Palmer, E.E.

is analyzed by means of the linear sweep in the monitor, producing the same varying patterns as seen at the actual transmitter. However, the patterns are those actually put out on the air and not signals picked up from the transmitter coils which, for a number of reasons, may be deceiving. While the characteristics of the receiver must be taken

to-judge variations in sound.

With the receiver monitor, however, you can state actual facts concerning the particular adjustment or change. This advantage alone has sold the receiver monitor system to many hams.

An added attraction is the fact that this monitor is in reality a full-fledged oscilloscope with a few added refinements, and as such may be used for all the many tasks possible with any 'scope equipped with a saw-tooth oscillator, horizontal and vertical amplifiers and a means of internal or external synchronization.

And to top it off, the low-voltage requirements of the 902 tube permit "receiving" parts to be used throughout. Dry electrolytic condensers, a receiver-type power transformer and a nidget choke coil all help to keep the cost low, compared with cathode-ray units using larger tubes, yet the screen on the 902 tube is over 2" across (only 1 inch less than the popular 3" tube).

The above description will
(Continued on page 413)

● EVERY up-to-date amateur station should be equipped with an indicator of modulation depth and character, if phone work is contemplated at any time. No modulated transmitter can possibly be operated efficiently and with good audio quality without a means of checking the effective percentage of modulation, grid excitation and antenna loading in order to insure proper adjustment of the modulated carrier put on the air.

This cathode-ray monitor using the new 2" type 902 tube was designed with a view toward supplying the ham with an instrument that will do everything a monitor can be expected to do—and a little more. It can be used to check the modulated output of the transmitter using a constant

tone for adjustment purposes or the varying signal during actual transmission can be watched for over- or under-modulation conditions. It can be used to produce the usual trapezoidal patterns of modulation percentage by feeding the modulated output of the rig to the vertical plates of the 'scope tube and the input modulator audio signal to the horizontal plates.

Still a third way used by the author with good results is to monitor the transmitter at the station receiver. This may sound rather far-fetched, but it really has many advantages. An i.f. coil tuned to the frequency of the i.f. amplifier of the receiver is built into the unit. A portion of the i.f. signal of the receiver at the output of the i.f. amplifier is fed through this coil to the vertical plates of the 'scope tube, through the vertical amplifier. The resulting pattern of the signal picked up (with the antenna disconnected to reduce signal pickup during transmitting periods in the usual manner)

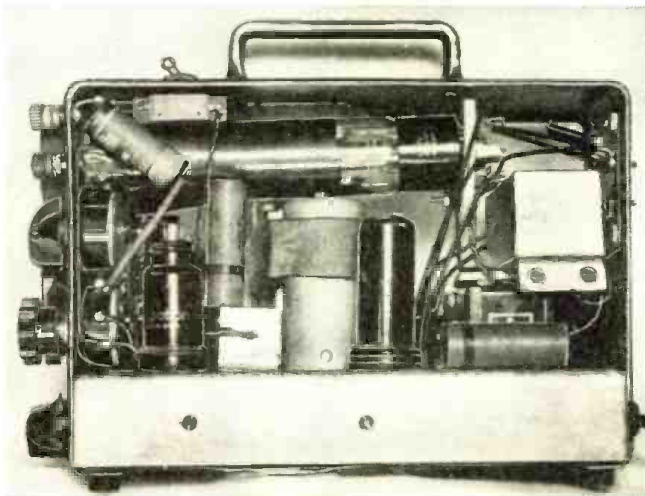

A view of the right side of the monitor, with shield cover removed.

into account, this factor is soon learned, and the advantages of monitoring at the receiver will be appreciated. For example, there is the possibility of reporting on other stations by monitoring their signals either from a constant tone or from the signal modulations transmitted. How many times have you been asked how some station sounds after adjustments have been made? And the only answer you can give is the uncertain opinion based on hard-

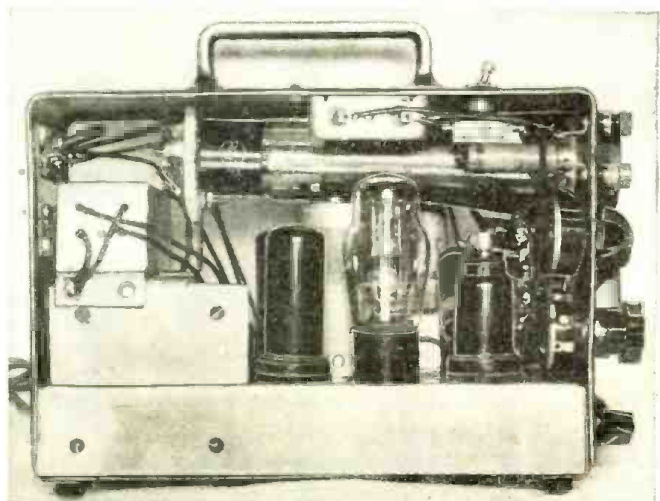

The C-R monitor from the left side—note the 2 inch type 902 C-R tube, which gives surprisingly fine definition.

Mc.	Call		Mc.	Call		Mc.	Call	
9.590	YUD2 YUD3	DELHI, INDIA, 31.28 m. Addr. All India Radio, 1.30-3.30 am., 7.30 am.-12.30 pm., 8.30-10.30 pm.	9.510	G5B	DAVENTRY, ENGLAND, 31.55 m., Addr. (See 9.580 mc.—G5C) 2-4.15 am., 1.30-4, 4.15-6, 6.20-8.30, 9.20-11.25 pm.	7.797	HBP	GENEVA, SWITZERLAND, 38.48 m., Addr. Radio-Nations.
9.590	PCJ	HUIZEN, HOLLAND, 31.28 m., Addr. (See 15.220 mc.) Sun. 2-3, 7-9.25 pm. Tues. 1.45-3.40, 7.15-8.45, 9-10.30 pm., Wed. 7.15-8.30 pm., Fri. 8-9 pm.	9.510	HJU	BUENAVENTURA, COLOMBIA, 31.55 m., Addr. National Railways. Mon., Wed. and Fri. 8-11 pm.	7.450	T12R3	SAN JOSE, COSTA RICA, 40.27 m. "Radioemisora Athena". 9.30-11 pm., exc. Sun.
9.590	VK6ME	PERTH, W. AUSTRALIA, 31.28 m., Addr. Amalgamated Wireless of Australasia, Ltd. 6-9 am. exc. Sun.	9.510	—	HANOI, FRENCH INDO-CHINA, 31.55 m. "Radio Hanoi". Addr. Radio Club de L'Indochine. 12 m.-2 am., 6-10 am.	7.410	HCJ84	QUITO, ECUADOR, 40.46 m., 7-9.30 pm. irregularly.
9.590	VK2ME	SYDNEY, AUSTRALIA, 31.28 m., Addr. Amalgamated Wireless of Australasia, Ltd., 47 York St., Sun. 1-3 am.; 4.30-8.30 am.; 9-11 am.	9.500	VK3ME	MELBOURNE, AUSTRALIA, 31.58 m., Addr. Amalgamated Wireless of Australasia, 167 Queen St. Daily except Sun. 4-7 am.	7.410	YDA	TANDJONGPRIOK, JAVA, 40.46 m., Addr. N.I.R.O.M., Batavia, 10.30 pm.-2 am.; Sat. 7.30 pm.-2 am.
9.590	W2XE	NEW YORK, N. Y., 31.28 m., Addr. CBS, 485 Madison Ave., Irregular.	9.500	XEWW	MEXICO CITY, MEX., 31.58 m., Addr. Apart. 2516. Relays XEW. 6 pm.-12 m.	7.380	XECR	MEXICO CITY, MEX., 40.65 m., Addr. Foreign Office. Sun. 7-8 pm.
9.590	W3XAU	PHILADELPHIA, PA., 31.28 m. Relays WCAU.	9.500	OFE	LAHTI, FINLAND, 31.58 m., Addr. Finnish Brst. Co., Helsinki. 2.15-5 pm.	7.220	HKE	BOGOTA, COL., S. A., 41.55 m. Tues. and Sat. 8-9 pm. Mon. and Thurs. 6.30-7 pm.
9.580	G5C	DAVENTRY, ENGLAND, 31.32 m., Addr. B. B. C., Portland Pl., London, W. 1, 6.20-8.30, 9.20-11.25 pm., 9 am.-12 m.	9.500	H58PJ	BANGKOK, SIAM, 31.58 m. Thursday, 8-10 am.	7.200	YNAM	MANAGUA, NICARAGUA, 41.67 m. Irregular at 9 pm.
9.580	VLR	MELBOURNE, AUSTRALIA, 31.32 m., Addr. Box 1686, G. P. O., Daily 3.30-8.30 am. (Sat. till 9 am.) Sun. 12.01-7.30 am. Also daily exc. Sat. 9:25 pm.-2 or 2.15 am. Sat. 5-10.30 pm.	9.488	EAR	MADRID, SPAIN, 31.6 m., Addr. (See 9.860 mc.) 7.30-8.30 pm. Mon., Tues., Thur., Sat. at 9.30 pm. also.	7.177	CR6AA	LOBITA, ANGOLA, PORT. WEST AFRICA, 41.75 m., Wednesday and Saturday 2.45-4.30 pm.
9.580	OAX5C	ICA, PERU, 31.32 m. Radio Universal 6-10 pm.	End of Broadcast Band			7.100	FO8AA	PAPEETE, TAHITI, 42.25 m., Addr. Radio Club Oceanien. Tues. and Fri. 11 pm.-12.30 am.
9.570	KZRM	MANILA, P. I., 31.35 m., Addr. Erlanger & Galingler, Box 283. Sun. 3-10 am. Daily exc. Sat. 4.30-7 pm., 11.15 pm.-12.15 am. Daily exc. Sun. 4-10 am.	9.445	HCODA	GUAYAQUIL, ECUADOR, 31.77 m. Irregularly till 10.40 pm.	7.088	PIIJ	DORDRECHT, HOLLAND, 42.3 m., Addr. Dr. M. Hellingman, Technical College. Sat. 11.10-11.50 am.
9.570	WIXK	SPRINGFIELD, MASS., 31.35 m., Addr. Westinghouse Electric & Mfg. Co. Relays WBZ 7 am. to 1 am. Sun. 8 am.-1 am.	9.437	COCH	HAVANA, CUBA, 31.8 m., Addr. 2 B St., Vedado. 8 am.-9.30 pm. Sun. 8 am.-12 m.	6.990	XEME	MERIDA, YUCATAN, 42.89 m., Addr. Calle 59, No. 517, "La Voz de Yucatan desde Merida." Irregular.
9.560	DJA	BERLIN, GERMANY, 31.38 m., Addr. Broadcasting House. 12.05-11 am., 7-10.45 pm.	9.380	—	TANANARIVE, MADAGASCAR, 31.96 m., Addr. Le Directeur des PTT, Radio Tananarive, Administration PTT. 12.30-12.45, 3.30-4.30, 10-11 am. Sun. 2.30-4 am.	6.977	XBA	TACUBAYA, D. F., MEX., 43 m. 9.30 am.-1 pm., 7-8.30 pm.
9.550	TPBII	PARIS, FRANCE, 31.41 m., Addr. (See 15.245 mc.) 2-4 am., 11.15 am.-6 pm.	9.355	HCJETC	QUITO, ECUADOR, 32.05 m., Addr. Teatro Bolivar, Thurs. until 9:30 p.m.	6.805	H17P	CIUDAD TRUJILLO, DOM. REP., 44.06 m., Addr. Emisora Diaria de Comercio. Daily exc. Sat. and Sun. 12.40-1.40, 6.40-8.40 pm. Sat. 12.40-1.40 pm. Sun. 10.40 am.-11.40 am.
9.550	W2XAD	SCHENECTADY, N. Y., 31.41 m., General Electric Co., 6.15-10 pm.	9.350	COCD	HAVANA, CUBA, 32.08 m., Addr. Box 2294. Relays CMCD 10 a.m.-11.30 pm. Sun. 10 am.-9 pm.	6.790	PZH	PARAMIRABO, SURINAM, 44.16 m., Addr. P. O. Box 18. Daily 6.06-8.36 am., Sun. 9.36-11.36 am. Daily 5.36-8.36 pm.
9.550	OLR3A	PRAGUE, CZECHOSLOVAKIA, 31.41 m. (See 11.840 mc.) Irreg.	9.345	HBL	GENEVA, SWITZERLAND, 32.08 m., Addr. Radio Nations. Off the air at present.	6.775	HIH	SAN PEDRO DE MACORIS, DOM. REP., 44.26 m. 12.10-1.40 pm., 7:30-9 pm. Sun. 3-4 am., 4.15-6 pm., 4.40-7.40 pm.
9.550	XEFT	VERA CRUZ, MEX., 31.41 m. 10.30 am.-4.30 pm., 10.30 pm.-12.30 am.	9.330	OAX4J	LIMA, PERU, 32.15 m., Addr. Box 1166, "Radio Universal." 12 m.-3 pm., 5 pm.-1 am.	6.750	JVT	NAZAKI, JAPAN, 44.44 m., Addr. Kokusai-Denwa Kaisha, Ltd., Tokyo. Irregular.
9.550	YDB	SOERABAJA, JAVA, 31.41 m., Addr. N.I.R.O.M. Daily exc. Sat. 6-7.30 pm., 4.30 to 10.30 am. Sat. 4.30-11.30 am.	9.300	HIG	CIUDAD TRUJILLO, D. R., 32.28 m. 7.10-9.40 am., 11.40 am.-2.10 pm., 3.40-9.40 pm.	6.730	HI3C	LA ROMANA, DOM. REP., 44.58 m., Addr. "La Voz de la Feria." 12.30-2 pm., 5-6 pm.
9.550	VUB2	BOMBAY, INDIA, 31.41 m., Addr. All India Radio. 9.30-10.30 pm., 12 m.-2.30 am.	9.280	HC2CW	GUAYAQUIL, ECUADOR, 32.31 m., 11.30 am.-12.30 p.m., 8-11 pm.	6.720	PMH	BANDOENG, JAVA, 44.64 m. Relays N.I.R.O.M. programs. 4.30-11 or 11.30 am. Also Sat. 9.30 pm.-1.30 am.
9.540	DJN	BERLIN, GERMANY, 31.45 m., Addr. (See 9.560 mc.) 4.50-10.45 pm.	9.200	COBX	HAVANA, CUBA, 32.59 m., Addr. San Miguel 194, Altos. Relays CMBX 7 am.-12 m.	6.690	TIEP	SAN JOSE, COSTA RICA, 44.82 m., Addr. Apartado 257, La Voz del Tropico. Daily 7-10 pm.
9.540	HJ5ABD	CALI, COLOMBIA, 31.45 m., Addr. La Voz de Valle, 12 n.-1.30 pm., 5.10-9.40 pm.	9.125	HAT4	BUDAPEST, HUNGARY, 32.88 m., Addr. "Radiolabor." Gyali-ut. 22, Sun. and Wed. 7-8 pm., Sat. 6-7 pm.	6.675	HBQ	GENEVA, SWITZERLAND, 44.94 m., Addr. Radio-Nations. Off the air at present.
9.540	VPD2	SUVA, FIJI ISLANDS, 31.45 m., Addr. Amalgamated Wireless of Australasia, Ltd. 5.30-7 am.	9.100	COCA	HAVANA, CUBA, 32.95 m., Addr. Galiano No. 102. Relays CMCA 9 am.-12 m.	6.672	—	44.94 m., relays Salamanca, Spain, 7-9.45 pm.
9.535	JZI	TOKYO, JAPAN, 31.46 m., Addr. (See 11.800, JZJ) Irregular.	9.091	PJCI	CURACAO, CURACAO, 50.33 m., Mon., Wed., Fri. 6.36-8.36 pm., Sun. 10.36 am.-12.36 pm.	6.672	YVQ	MARACAY, VENEZUELA, 44.95 m. Irregular.
9.535	—	BERNE, SWITZERLAND, 31.46 m., 1-2 pm. exc. Mon. and Tues.	9.030	COBZ	HAVANA, CUBA, 33.32 m., Radio Salas Addr. P. O. Box 866. 7.45 am.-1.15 am. Sun. 7.45 am.-12 m. Relays CMBZ.	6.635	HC2RL	GUAYAQUIL, ECUADOR, S. A., 45.18 m., Addr. P. O. Box 759. Sun. 5.45-7.45 pm., Tues. 9.15-11.15 pm.
9.530	W2XAF	SCHENECTADY, N. Y., 31.48 m., Addr. General Electric Co., 4 pm.-12 m.	8.965	COKG	SANTIAGO, CUBA, 33.44 m., Addr. Box 137. 9-10 am., 11.30 am.-1.30 pm., 3-4.30, 5-6, 10-11 pm., 12 m.-2 am.	6.630	HIT	CIUDAD TRUJILLO, D. R., 45.25 m., Addr. "La Voz de la RCA Victor." Apartado 1105. Daily exc. Sun. 12.10-1.40 pm., 5.40-8.40 pm.; also Sat. 10.40 pm.-12.40 am.
9.530	VUC2	CALCUTTA, INDIA, 31.48 m., Addr. All India Radio. 2.06-4.06 am.	8.841	HCJB	QUITO, ECUADOR, 33.5 m. 7-8.30 am., 11.45 am.-2.30 pm., 5-10 pm., except Mon. Sun. 12 n.-1.30 pm., 5.30-10 pm.	6.625	PRADO	RIOBAMBA, ECUADOR, 45.28 m. Thurs. 9-11.45 pm.
9.526	XEDQ	GUADALAJARA, GAL., MEXICO, 31.49 m. Irregular 7.30 pm. to 12.30 am.	8.700	HKV	BOGOTA, COLOMBIA, 34.46 m. Tues. and Fri. 7-7.20 pm.	6.610	YNLG	MANAGUA, NICARAGUA, 45.39 m., Emisora Ruben Dario. 1-3, 7-11 pm.
9.526	ZBW3	HONGKONG, CHINA, 31.49 m., Addr. P. O. Box 200. 11.30 pm. to 1 am., 3-10 am.	8.665	COJK	CAMAGUEY, CUBA, 34.64 m., Addr. Finlay No. 3 Altos. 5.30-6.30, 8-11 pm., daily except Sat. and Sun.	6.558	HI4D	CIUDAD TRUJILLO, D. R., 45.74 m. Except Sun. 11.55 am.-1.40 pm.
9.525	LKJI	JELOY, NORWAY, 31.49 m. 5-8 am.	8.665	W2XGB	HICKSVILLE, N. Y., 34.64 m., Addr. Press Wireless, Mon. to Fri. News at 9 am. and 5 pm.	6.550	X8C	VERA CRUZ, MEX., 45.8 m. 8.15-9 am.
9.523	ZRH	ROBERTS HEIGHTS, S. AFRICA, 31.5 m., Addr. (See ZRK, 9.606 mc.) Daily exc. Sun. 5-7.30 am.; Sun. 5.30-7 am.	8.580	YNPR	MANAGUA, NICARAGUA, 34.92 m. Radiodifusora Pilot.	6.550	TIRCC	SAN JOSE, COSTA RICA, 45.8 m., Addr. Radioemisora Catolica Costarricense. Sun. 11 am.-2 pm., 6-7, 8-9 pm. Daily 12 n.-2 pm., 6-7 pm., Thurs. 6-11 pm.
9.520	OZF	SKAMLEBOAEK, DENMARK, 31.51 m., Addr. Statsradionien, Heibergsgade 7, Copenhagen, 2-6.40, 8-11 pm.	7.894	YSD	SAN SALVADOR, EL SALVADOR, 37.99 m., Addr. Dir. Genl. Tel. & Tel. 7-11 pm.	6.545	YV6RB	BOLIVAR, VENEZUELA, 45.84 m., Addr. "Ecos de Orinoco." 6-10.30 pm.
9.520	YSH	SAN SALVADOR, EL SALVADOR 31.51 m., Addr. (See 7.894 mc.) Irregular 6-10 pm.	7.870	HC1RB	QUITO, ECUADOR, 38.1 m. La Voz de Quito. 9-11 pm.	6.520	YV4RB	VALENCIA, VENEZUELA, 45.98 m. 11 am.-2 pm., 5-10 pm.
			7.854	HC2JSB	GUAYAQUIL, ECUADOR, 38.2 m. Evenings to 11 pm.	6.516	YNIGG	MANAGUA, NICARAGUA, 46.02 m., Addr. "La Voz de las Lagos." 8-9 pm.

(Continued on page 432)

All Schedules Eastern Standard Time

(Continued from page 411)

suffice for a general outline of what can be done with this versatile station monitor. Later, actual instructions for connecting the unit to transmitter and receiver for various modulation measurements and for use as an oscillograph will be given.

The entire unit is enclosed in a small metal box 3" x 6 1/2" x 9 1/2" deep. This includes, the C.R. tube, power-supply, sweep, amplifiers and all—yet, though parts are somewhat crowded, no ill effects are noticeable. The power transformer is well shielded and placed so that the least number of magnetic lines of force cross the line of the electron stream in the C.R. tube. The filter choke is mounted under the chassis, out of harm's way. All controls are located on the end with the screen of the tube, where they are most accessible.

These controls are used for the purposes shown on the illustration, Fig. 1.

An examination of the circuit, Fig. 2, shows the make-up of the unit. The power supply utilizes two 5Z4 tubes, one of which is used as a half-wave rectifier feeding the cathode-ray tube, while the other is connected as a full-wave rectifier, supplying

current to the amplifier tubes and the thyratron. A single 8 mf., 475-volt dry electrolytic condenser filters the current supplied to the C.R. tube. The positive terminal of the C.R. tube supply is grounded in accepted oscilloscope manner, as this puts the high potential points of the circuit as far as possible

The low voltage requirements of the 902 C-R tube permits the use of receiving type parts, thus cutting the cost of this monitor down to a minimum. Very fine images are produced on the 2" screen.

from the chassis potential. Two 8 mf. electrolytic condensers, together with a small size 30-henry choke, filter the amplifier and sweep circuits. The output of the full-wave rectifier has the negative end grounded, so that the chassis can be used as ground for the amplifier tubes.

The sweep circuit is conventional, using a type 885 tube with a series of condensers connected between plate and cathode by means of a switch and a 2 meg. resistor in series with the plate-supply to control the plate voltage. These represent the rough and fine frequency controls of the horizontal sweep circuit, respectively. A 25,000 ohm resistor in series with the grid of the 885 tube limits the flow of grid current and thus prevents the plate current from exceeding the manufacturer's rated limit.

Synchronization of the sweep with alternating voltages applied to the vertical plates is accomplished by one of three methods:— first, by applying a small 60 cycle A.C. potential to the grid, thus locking this circuit with the supply line; second, by opening the switch in the grid circuit and connecting the terminal at the grid to the "Amp. Sync." terminal, which applies a small part of the signal at the plate of the vertical amplifier to the sweep tube grid, thus locking the sweep with the voltage applied to the vertical plates; and third, an external synchronizing voltage can be connected to the "Ext. Sync." terminal.

(Continued on page 427)

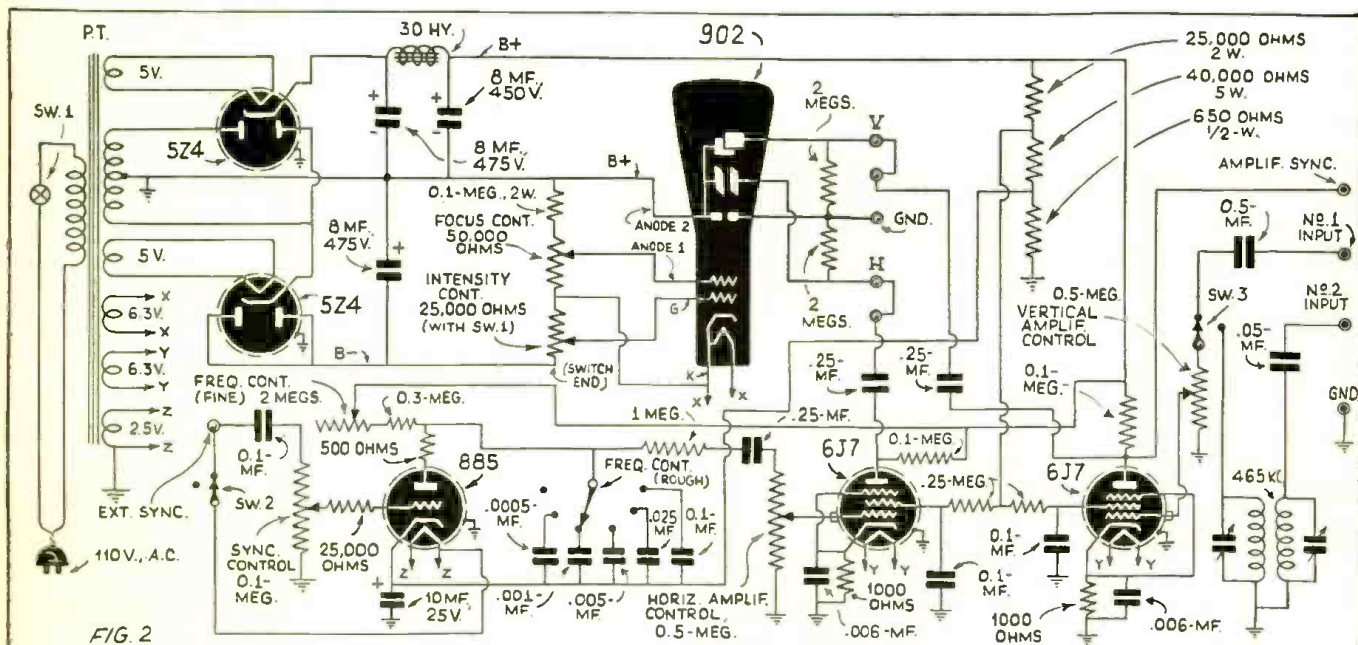

FIG. 2

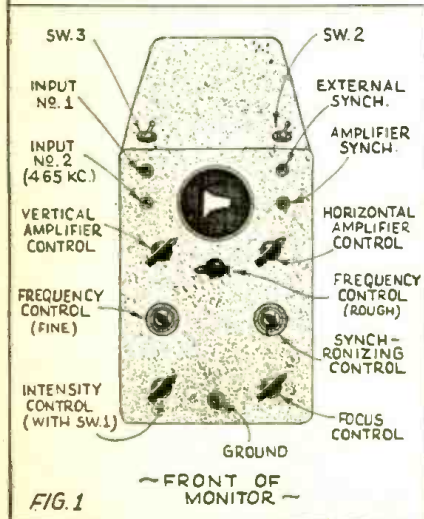

FIG. 1

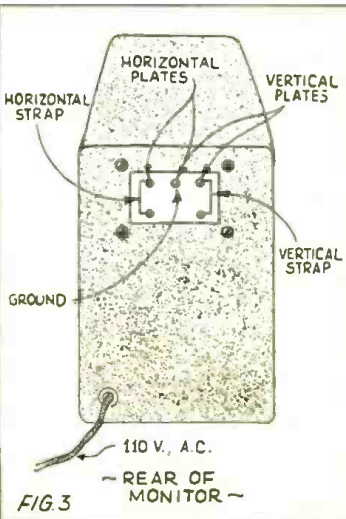

FIG. 3



FIG. 4

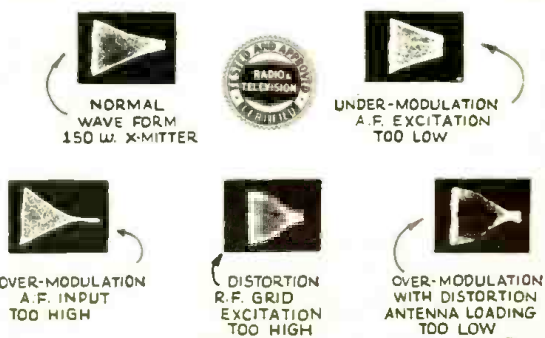

FIG. 5

Wiring diagram for building the cathode-ray tube monitor is given above as are typical oscillograms; i. e., patterns which indicate different conditions in transmitter operation.

You Can Easily Build this 441-Line

T. R. F. Television Receiver

Henry Townsend

The writer, well known in the field of television engineering for a number of years, has developed a fool-proof receiver which can be built out of standard parts to reproduce images transmitted by the various 441-line stations in the United States.

Part I provides a description of the Power Supplies, Sweep Circuits, Synchronizing Impulse Separator, the D.C. Restoring Circuit, and Cathode-Ray Tube Mount. Part II will describe the R.F. and detector circuits.

TELEVISION HAS TECHNICALLY BEEN DEVELOPED TO A HIGH DEGREE. THIS ARTICLE PROVIDES THE LATEST INFORMATION. IT WILL BE SOME TIME BEFORE HOME TELEVISION IS REALIZED. THE ART HAS GREAT OPPORTUNITIES FOR EXPERIMENTERS AND TECHNICIANS.

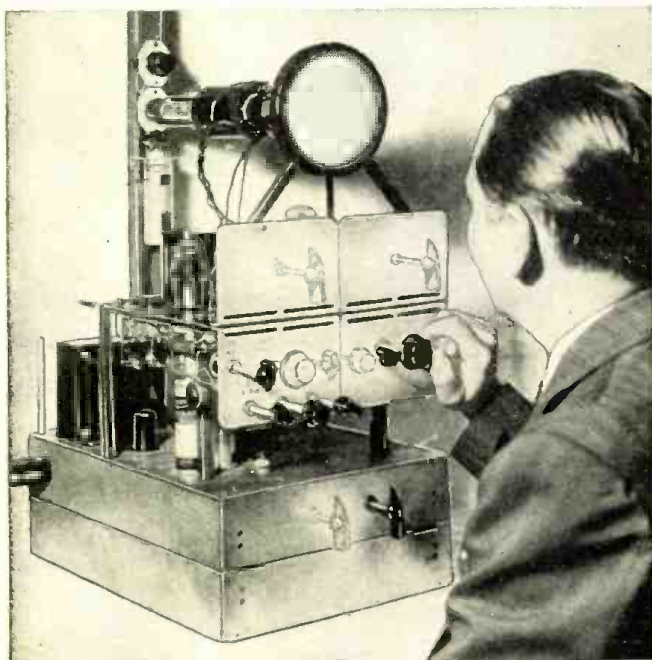
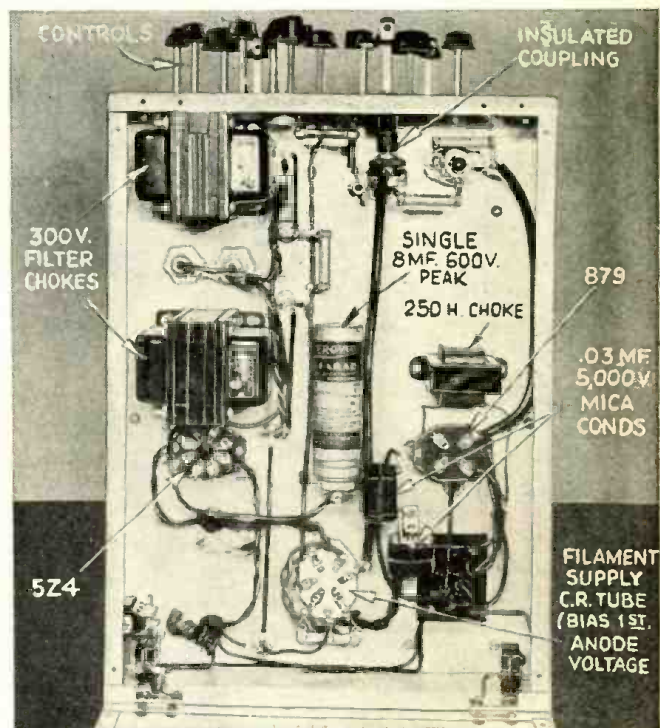

Fig. A. The controls, left to right, are:—Top pair, Low frequency (vertical) synchronizer input*, and High frequency (horizontal) synchronizer input*. Next row, Low frequency sweep control, L.F. size control*, L.F. synchronizing separator*, High frequency synchronizing separator*, H.F. speed control, Vernier for same, and H.F. size control*. Third row, Bias on right hand section of 6F8G*, Peaking (60-cycle) control*, and Bias on left hand section of 6F8G*. Bottom pair, brilliancy control for C-R tube, and 1st Anode voltage control for C-R tube. Controls marked *(shown in phantom) may be slotted shafts, and need not be brought out through panel; once set, they may be left without further adjustment until receiver is moved to new location.

● I HAVE just completed field tests on something new in television receivers. The *new* feature is that it *actually works!* The set was assembled from parts which are obtainable at any radio store, and the whole work of constructing the receiver took only about 72 hours. The set functioned on its first trial, but a few minor adjustments were necessary in order to get a degree of perfection comparable to that of the commercial receivers now produced.

The receiving circuits of the set are merely modifications of standard practice and should present no unusual problems for the experimenter. The cathode-ray tube unit, low and high frequency sweep circuits and a synchronizing impulse separator are here illustrated. This first article will describe the construction of the cathode-ray unit and will include the easily constructed power-packs, which may as well be constructed immediately and placed to one side to be ready for use as the set progresses. One power-pack must deliver an output of 3000 volts for various anode voltages of the cathode-ray tube. The first anode voltage of 500 volts comes from a voltage divider in the bleeder circuit of this power-pack. This control should be insulated from the chassis for the full 3000 volts. A bakelite coupling unit

Fig. B. Under view of top power-pack pan. The under pan, hinged to it, is used only as a support and shield.



Wiring Diagram for Power Supplies and Sweep Circuits

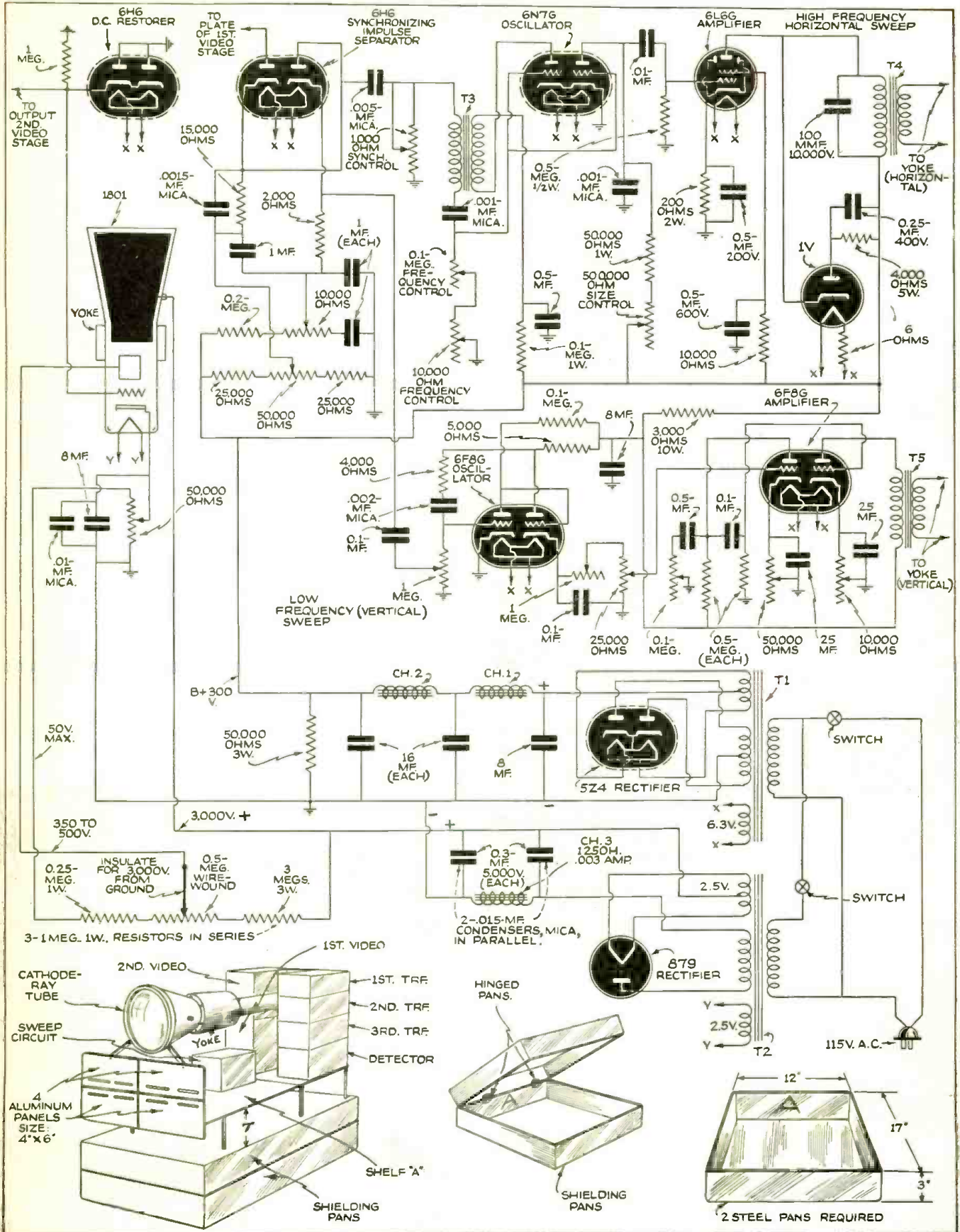

The power-pack offers no difficulties—but watch out for that high voltage! The 879 is the high voltage rectifier; the 5Z4 rectifies for the receiver. The sweep circuits, separator and D.C. restorer. The 6N7 is the high frequency sweep oscillator, the output of which is amplified by the 6L6G, while the 1V tube acts as a damping tube. One 6F8G

performs as a low frequency sweep oscillator, while the other amplifies its output. Of the two 6H6's, one is the D.C. restorer, the other—the synchronizing impulse separator. Note that the by-pass condenser for the C-R tube is mounted at the base of the cathode-ray tube which it supplies, and is NOT in the power-pack.

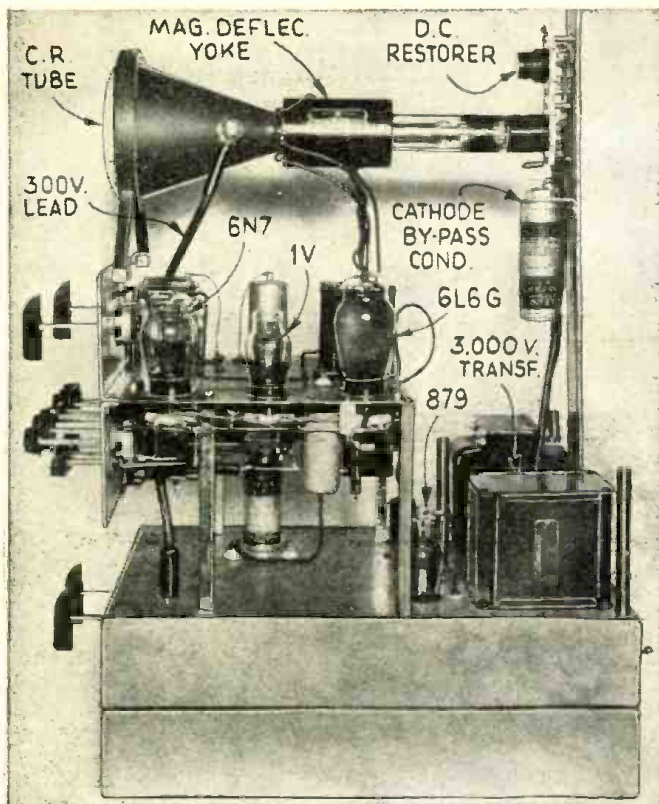

Fig. C. Right-hand view of assembly. The R-F stages are mounted beside the rear panel which supports the C-R tube. The heavy lead from the pan to the C-R tube is the 3,000-V. lead.

should be inserted between the shaft coming to the front of the panel and the shaft on the potentiometer. (Refer to photograph No. B.) The power-pack is simply a well filtered 300 volt unit for supplying the operating voltages of the receiver and sweep circuits. Two standard 17"x12"x3" pans are hinged together and form a completely shielded compartment for both power supplies. It might be well to mention that great care should be taken in assembling the high voltage power-pack; no leads should be exposed, as these voltages are dangerous should one accidentally get in contact with them. Photographs show the approximate placement of parts and no difficulty should be encountered in wiring these power-packs. Standard automobile spark plug cable should be used for the output of the high voltage leads in the 3000 volt unit.

The standard 300 volt pack is the usual type of power supply one would build for a standard broadcast receiver delivering 125 milliamperes, with the possible exception that 16 mf. are used instead of the usual 8 for filtering.

A number of experiments have been made to determine the simplest form for the sweep circuits, synchronizing separators and power units, and it was found that each item described in this constructional article was fool-proof, easily adjusted and highly satisfactory in performance.

Of the several types of sweep circuits that are used in sweeping the spot of the cathode-ray tube across the fluorescent screen, it has been decided that for the low frequency sweep, the multi-vibrator type (as suggested by Bedford & Puckles) is the most stable and easily constructed. Two 6F8G tubes (of the dual type) are used, as will be noted from the schematic diagram. One tube is so connected that it forms a resistance-capacity coupled type of amplifier with feed-back to make this circuit oscillate. The second tube is used to amplify these sawtooth impulses. The output of this amplifier is connected to the yoke through the output transformer. The high frequency oscillator circuit uses three tubes—the first tube, a 6N7, is so connected as to form a blocking type oscillator; the second tube is 6L6G and is the output tube. A type 1V, operated at 5 volts, absorbs the circuit shock excitation oscillation produced by coupling the yoke with the output transformer and reflecting back the spurious oscilla-

tions in the plate of the 6L6. This tube smooths out the sawtooth impulses so that they are of the proper wave form when applied to the deflecting yoke.

Both of these sweep circuits are designed to give sufficient sweep for either a 5" or 9" tube. The synchronizing impulse separator is used to separate the synchronizing impulses transmitted, from the picture impulses. These occur once for every line of the sweep in the horizontal direction and once for every frame of the picture in the vertical direction. A 6H6 type tube is used for this purpose. Another 6H6 type tube is used for the d.c. restoring circuit. This tube establishes the background level of the picture and is mounted directly above the cathode-ray tube socket, as shown in photograph No. C. In photograph No. D on the left side, are assembled the low frequency sweep circuit and the synchronizing impulse separator. The right-hand side of the photograph shows the high frequency circuit. This unit is mounted on the upper pan of the power-pack chassis, as shown in the photographs. Great care should be used in wiring these circuits, due to the dual type tubes used in them.

A list of standard parts is given at the end of this article, and the values given should not be deviated from.

Assuming that the constructor has completed the television receiver thus far described, the unit can be tested, and no difficulty should be experienced in forming a pattern on the face of the cathode-ray tube, which has an aspect ratio of 3 to 4. The picture can be used either as a square or stretched out beyond the ends of the tube, filling the complete face of the 5" cathode-ray tube.

If this unit has been correctly constructed, you will see a pattern on the face of the cathode-ray tube, consisting of a great number of horizontal lines. This pattern can be stretched vertically and horizontally by adjusting the size control. Should this pattern fail to appear, some mistake has been made in the wiring of the sweep circuit and careful check will disclose where the trouble lies.

If the 1V tube is taken out of the socket, a bright vertical line should appear in the rectangle scanned on the face of the cathode-ray tube, showing that the saw-tooth current in the yoke is not linear, due to the spurious oscillation present.

In the next and concluding installment, the radio frequency

Fig. D. Left-hand view. The video amplifier attaches to the rear panel on this side.

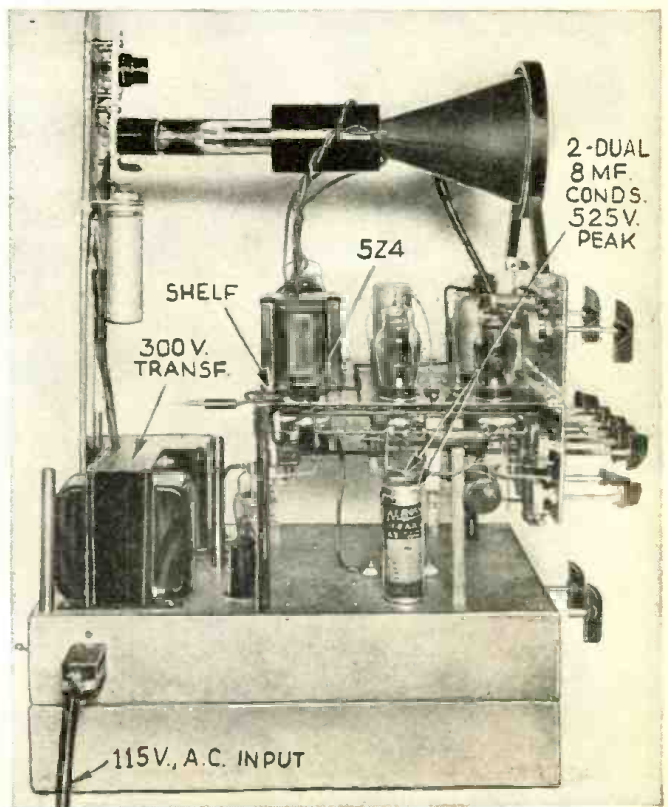

unit and *video amplifier* will be described, together with a recommended antenna system, to produce best results.

List of Parts

RCA (Tubes)

- 1—1801 5" cathode-ray tube
- 1—879 rectifier

Electrolytic Condensers

AEROVOX

- 1—8 mf. 600 V. Peak
- 1—8 mf. 200 V. Peak
- 3—8.8 mf. 525 V. Peak
- 2—50 mf. 50 V. Peak

Fixed Condensers

AEROVOX

- | | |
|------------------|-------------------|
| (Paper) | (Mica) |
| 1—.25 mf. 200 V. | 1—.0015-1000 V. |
| 3—1.0 mf. 400 V. | 1—.0001-10,000 V. |
| 3—.05 mf. 600 V. | 2—.001-1000 V. |
| 2—.1 mf. 400 V. | 4—.015-5000 V. |
| 3—.5 mf. 400 V. | 2—.005-500 V. |
| | 1—.01-500 V. |

Variable Resistors

I.R.C.

- 2—1.0 meg.
- 1—1000 ohm
- 1—500,000 ohm
- 3—10,000 ohm
- 2—50,000 ohm
- 2—100,000 ohm
- 1—25,000 ohm

CLAROSTAT

- 1—50,000 ohm (wire)
- 1—500,000 ohm

Fixed Resistors

I.R.C.

- | | | | |
|----------|-----------|----------|---------|
| 1/2 Watt | 1 Watt | 3 Watts | 5 Watts |
| 1—1 meg. | 2—100,000 | 1—200 | 1—3500 |
| 3—5 meg. | 1—200,000 | 1—10,000 | 1—4000 |
| | 1—500,000 | 2—2000 | |
| | 2—25,000 | 1—50,000 | |
| | 1—15,000 | | |
| | 1—50,000 | | |
| | 1—4,000 | | |
- 1—6.0 ohm wire

Sockets

HAMMARLUND

- 7—8-Prong Isolantite
- 2—4-Prong Isolantite
- 1—5-Prong Isolantite

PAR-METAL

- 2—Classis 12"x17"x3"

Transformers & Chokes

RCA

- 1—Trans. 9835

STANCOR

- 1—P5059 trans.
- 2—C1412 chokes

THORDARSON

- 1—T29C27 choke

KENYON

- 1—T203 trans.
- 1—T111 trans.
- 1—T112 trans.
- 1—T700 deflecting yoke

RAYTHEON (Tubes)

- 1—6L6G
- 1—1V
- 1—6N7G
- 2—6F8G
- 2—6116
- 1—5Z4

ALCOA

- 4—Brackets 4"x6" 1/2" bend
- 1—10"x12" 16 gauge (iron) sheet (or aluminum)

Hardware & Miscellaneous

- 2—1/2"x1" hinges
- 1—115 volt outlet plug and cord
- 1—Bakelite ring 5/8" diam. 1/2" wide
- 2—1/4"x1/2"x3/32" brass
- 1—1/4"x2"x20" aluminum
- 1—Bakelite 1/4" coupling and shaft
- Angle brackets
- Assorted 6-32 and 8-32 screws and nuts
- 2—115 V. toggle switches
- 4—1/2"x1/2"x7" brass posts (tapped both ends) (8-32)
- 4—1/2"x1/2"x4 3/4" brass posts (tapped both ends) (8-32)



I'm glad I waited for this FREE CATALOG!

In fact, I use it as my buying guide. Its 188 pages are crammed with radio, camera and appliance values that save me real money. And shopping at home sure saves me plenty of time and trouble. You ought to send for your copy right away.



1939 LAFAYETTE RECEIVERS
The biggest radio values of them all! Sleek, new, styled to the minute beauty — clear, powerful, realistic reception — perfect touch tuning — Lafayette for 1939 combines all the extra-value features you'd expect to find only in much higher priced sets. Listen to Lafayette before you buy any new radio. Select from 50 brilliant models described and illustrated in our new FREE catalog.

PARTS, TUBES AND KITS
Whether you build it yourself or fix it yourself, this book has everything you need. Parts — tubes — hard-to-get items in radio. Use our FREE catalog for easy, economical shopping.

PUBLIC ADDRESS EQUIPMENT
Lafayette P.A. is doing smash business everywhere! This year, there is a Lafayette unit for every sound purpose. New performance... the same old thriftiness. See the complete P.A. line in our new catalog. Special List Price P.A. Division for servicemen. Write to P.A. Division.

HAM EQUIP'T & APPARATUS
Save important money on quality ham equipment! Select your favorite transmitter... all the accessories you need, from this value-packed radio catalog.

TO give you an idea of what this big FREE catalog (just published) will mean to you, we've listed at the left a few of the items it contains. But this doesn't tell you half the story. There is, for example, the new television kit, designed to "let you in" on things to come, give you some practical experience with the radio equipment of tomorrow. You'll want to see it, and you'll be surprised at how little it costs. There's the new camera section featuring all the leading makes of cameras for amateur and professional, as well as complete photo equipment and supplies. There are tools and every conceivable electrical appliance for home and workshop. Here's a catalog that's value-packed from cover to cover. Send for your FREE copy at once!

You save on everything you buy. You have more than 50,000 items to choose from. You get value far beyond price.

7 branches to serve you
WHOLESALE RADIO SERVICE CO. INC.
NEW YORK, N.Y. • CHICAGO, ILL. • ATLANTA, GA.
100 SIXTH AVENUE • 901 W. JACKSON BLVD. • 205 PEACHTREE STREET
BOSTON, MASS. • BRONX, N.Y. • NEWARK, N.J. • JAMAICA, L.I.

BUY BY MAIL OR IN PERSON
Either way, you benefit. Delivery service is rapid. Our staff understands your problems.

VALU-BILL Says:
Just paste 'er on a penny post-card and mail. If you don't say it's the best one cent investment you ever made, we'll refund your money! Don't wait.
Send for it today!

WHOLESALE RADIO SERVICE CO., INC.
100 Sixth Avenue, New York, N. Y.
Rush FREE 1939 Catalog No. 73-418

Name _____
Address _____
City _____ State _____

Build this 5 to 50 Meter Superhet.



Front view of 6-tube Superhet.

Features: Regeneration-operation on a.c. or batteries—A.V.C. with "on"- "off" switch—loud-speaker or headphone operation—beat oscillator for c.w. reception and easy spotting of "DX" stations.

● DURING the past three or four years the ultra-high-frequency amateur bands have become so crowded that it is almost impossible to carry on a QSO for any length of time without being QRMed "out of the picture" by half a dozen other stations. Until recently the use of a superheterodyne re-

ceiver was almost unheard of, not because of any deficiency in the circuit itself, but because of the poor frequency stability of the average amateur transmitter. With the development of the new 10 meter crystals, however, it is more than likely that the majority of the ultra-high-frequency hams will be using crystal-controlled transmitters on these bands and the superhet. will become the standard receiver as it has done on the lower frequencies.

5 to 50 Meter Range

The 6-tube superheterodyne to be de-

scribed in this article has been designed especially for the range from 5 to 50 meters. As Fig. 1 shows, the circuit has been kept as simple and straightforward as possible, consisting of a 6K8 as mixer-oscillator, two 6S7s as I.F. amplifiers, a 6R7 as detector, A.V.C. and beat oscillator, a 6F8G as two stages of resistance-capacity coupled audio amplification and a 6F6 as output. The rectifier is a 5Y4G. The tubes listed above, with the exception of the 6F6 and 6R7, are of recent release. The 6K8 is especially interesting as it is essentially a 6L7-6C5 mixer-oscillator arrangement combined in

Wiring diagram of 5 to 50 meter Superhet.

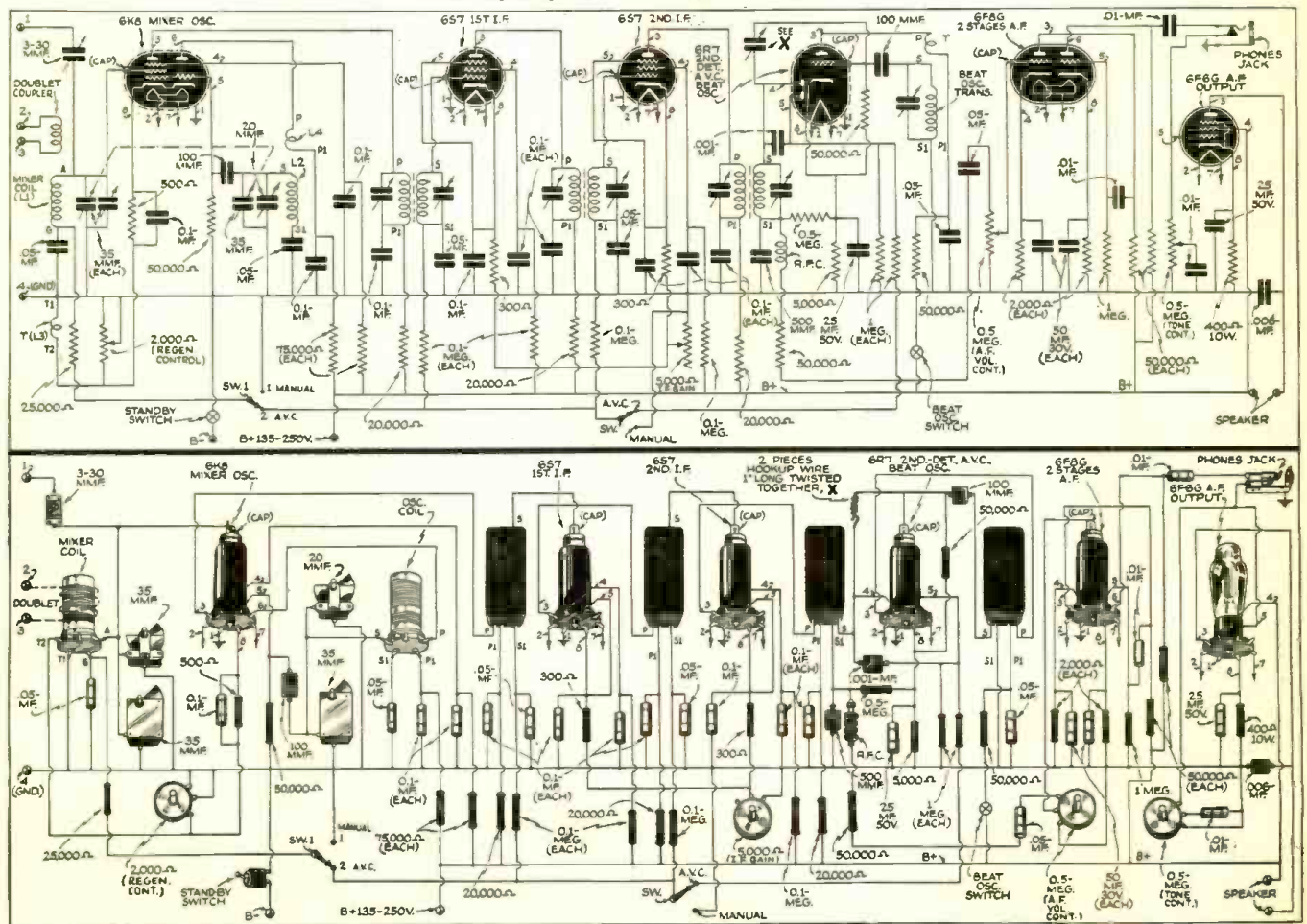

6-Tube Receiver

Harry D. Hooton,
W8KPX

one metal shell. The control-grid of the triode section is connected internally to the hextode grid No. 1, the lead being brought out to pin No. 5. According to the engineering data supplied by the manufacturer, there is small variation in transconductance of the triode unit with changes in bias on hextode control-grid No. 3. As a result, the full A.V.C. action may be applied to the mixer, if desired, without appreciably affecting the oscillator frequency. The 6S7 is quite similar to the older 6K7, except that it will operate satisfactorily with plate and screen voltages as low as 135 and 67 volts respectively; the heater drain is only 0.15 ampere—one-half that of the 6K7—which is desirable if the receiver is ever to be operated from a 6-volt battery. The 6F8G is the new twin-triode tube featured in the W2AMN beginner's 1-tuber on page 686 of the April 1938 issue and in the author's 4-tube TRF set which was described in the August number. Plug-in coils, four sets being required, are employed to cover the range from 5 to 49 meters.

Regeneration Feature

The mixer is made *regenerative* or vice versa at will; when the 2,000 ohm potentiometer is turned completely "off," the tickler coil is *short-circuited* and the hextode portion of the 6K8 functions in the usual manner. Tone, i.e. gain, regeneration and volume controls have been provided for maximum flexibility and are located on the front panel as indicated in Fig. 3.

Coil Data

MIXER COILS

Band	Spacing	Turns	Tickler
7.0 mc. †	1 1/2"	18 No. 24	7 turns No. 30
14 mc. †	1 1/2"	9 No. 16	4 turns No. 30
28 mc.	1"	4 No. 16	3 turns No. 30
56 mc.	3/4"	2 3/4 No. 16	2 turns No. 26 interwound

OSCILLATOR COILS

Band	Spacing	Turns	Tickler
7.0 mc. †	1 1/2"	14 No. 24	7 turns No. 30
14 mc. †	1 1/2"	8 No. 16	4 turns No. 30
28 mc.	1"	4 No. 16	3 turns No. 30
56 mc.	3/4"	2 3/4 No. 16	2 turns No. 30 interwound

†The 7.0 and 14 megacycle coils are wound on standard 1 1/2 inch 5-prong XP-53 forms; the 28 and 56 mc. coils are wound on midget 1" forms. Spacing refers to length of winding on coil form, not the distance between turns. All grid windings are tinned bare copper wire; all tickler windings are double silk covered copper wire.

(Continued on page 423)

A NEW Edition

Thoroughly revised—greatly enlarged and offering a wealth of new up-to-minute information

THE RADIO MANUAL



Here's the only complete Handbook for students, amateurs, operators, and inspectors. It covers the entire field of radio in 1,000 pages with hundreds of illustrations and diagrams. It is actually a complete course of training in radio operation and a complete reference book for everyone in the field. It gives instantly the answer to every question about principles, methods, and apparatus of radio transmitting and receiving.

A Complete Course in a Single Volume New 1938 Edition

Covers in full detail the Electron Tube—Vacuum Tube Amplifiers and Oscillators—Modulation and Modulation Analysis—Microphones—Radio and Audio Frequency Measurements—Antenna Resistance Measurements—Latest Broadcast Transmitters with installations, adjustments, operation, and maintenance instructions—Latest Marine Radiotelegraph Transmitters and Receivers—Duties of Ground Station Radio Operators—Theory, Operation and Use of Radio Range and Marker Beacons (localizers), Landing Beams including Lorenz System of Instrument Landing—Radio Direction Finder—the two U. S. Auto Alarms approved by the F. C. C.—Ultra-high Frequency Police Transmitters and Receivers—All Important Radio Provisions of the Communications Act of 1934 as amended effective 1937—Rules and Regulations of F. C. C.—General Radio Regulations Governing Distress Signals, etc.

New Information Never Before Available

This is just a hint of the vast amount of new information packed into this great book. In addition, the entire field of Radio is covered in complete detail, making The Radio Manual essential to every student, operator, and inspector.

Prepared by F. C. C. Expert

The author, G. E. Sterling, is Assistant Chief, Field Section, Engineering Dept., Federal Communications Commission.

FREE EXAMINATION

The Revised Edition of "The Radio Manual" has just been published. Over 1000 pages. Hundreds of illustrations. Bound in Flexible Fabrikoid. The coupon brings the volume for free examination. If you do not agree that it is the best Radio book you have seen, return it and owe nothing.

Clip and Mail This Approval Order Form

D. VAN NOSTRAND CO., 250 Fourth Ave., New York

Send me on approval THE RADIO MANUAL. Within 5 days after I receive the book, I can return it and owe nothing. If I keep it, I will send you \$2.00 as first payment and I will pay \$2.00 monthly thereafter for 2 months—\$6.00 in all. (5% discount for cash.) (R.&T.-11.)

Name

Address

City State

Reference

Address

FOR FREE CATALOG of best books of practical instruction and technical information, check here. If you do not want The Radio Manual cross out paragraph above.

110 Volt Direct Current TRANS-

Herman Yellin, W2AJL



Front view of the D.C. Transmitter.

● THE amateur residing in a direct current district and desirous of operating a transmitter has little choice in the selection of a power-supply—he must either use a motor-generator set or make the best of the situation by using the 110 volts with a flea-power transmitter. A motor-gener-

ator set, besides being an expensive piece of machinery and therefore unavailable to most amateurs, is generally unwelcome in the modern apartment house. The average amateur is therefore faced with the problem of building a transmitter to operate directly on 110 volts, with the hardly satisfying thought that no large transformers, rectifiers and filters will be necessary.

That the problem is indeed a serious one

is attested to by the lack of suitable tubes. Although there seemingly are many tubes designed for 110 volt operation, a glance at the tube manual elicits the information that the power output is woefully small. However, power is *not* everything. Many an amateur is doing excellent dx work with a power input as low as five watts. Naturally, he cannot do it as consistently as his high-power brother, but then the amateur is not running a commercial traffic circuit and consistent long range is not essential.

25L6 Tubes Selected

Recently the author was faced with the problem of designing an inexpensive transmitter for just such operation. Perusal of tube handbooks resulted in the decision to use 25L6 tubes throughout the "rig"; one of the metal type being used in a tri-tet oscillator and four of the glass type in a push-pull parallel final amplifier. In practice, inputs of 15 to 20 watts were easily had. Incidentally little difference was noticed between the glass type tube and the metal tube.

Hook-up for the Transmitter.

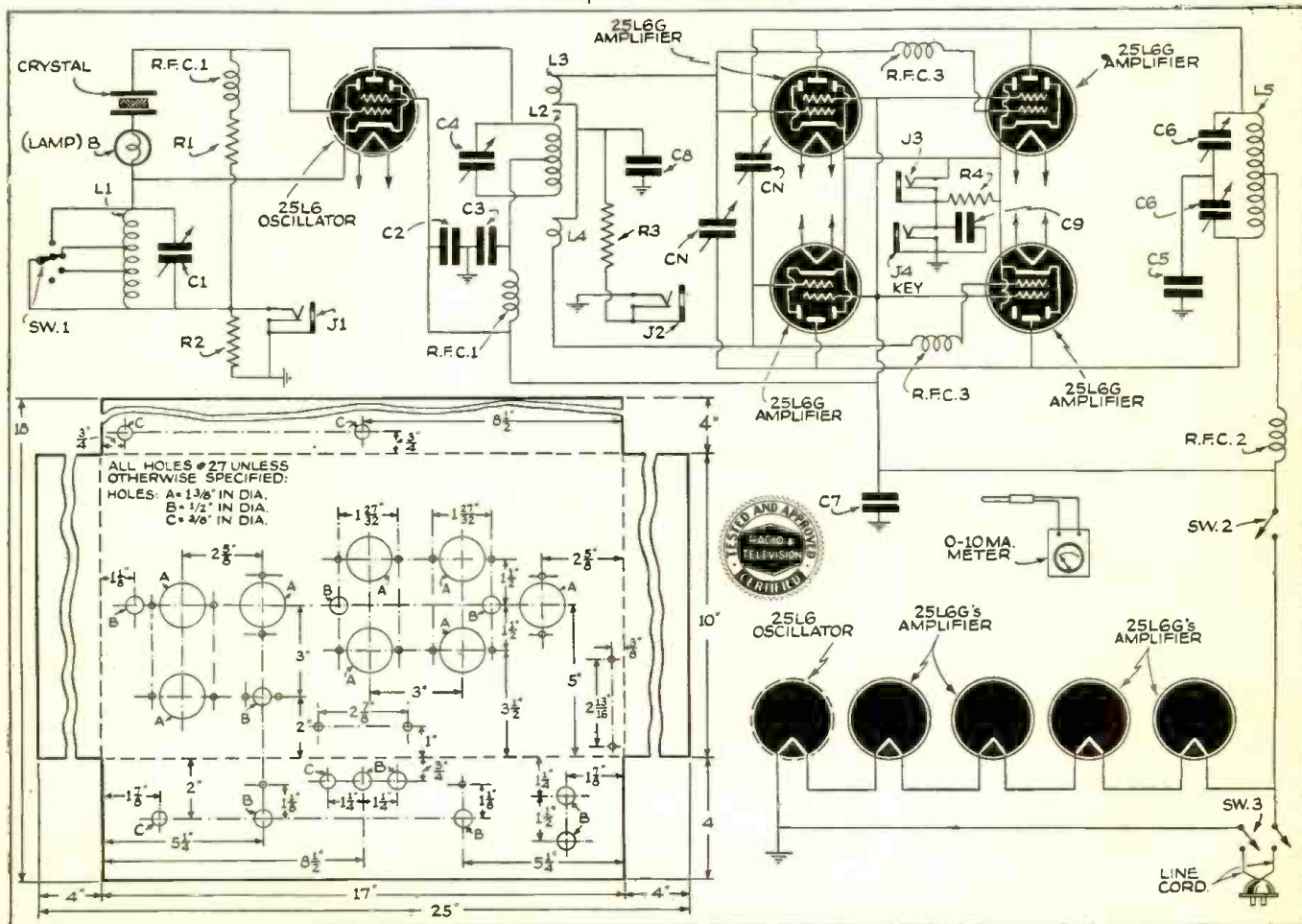

Build This 5 to 50 Meter 6-Tube Superhet. Receiver

(Continued from page 419)

The oscillator coil is at the left nearest to the 6K8 tube.

Short Leads Essential

It is necessary to keep the plate, grid and diode leads from the I.F. transformers as short as possible. Place these leads right against the metal chassis in order to limit their external fields; if oscillation and a high noise-level are encountered, it may be necessary to shield a part or all of these leads with the usual braided copper shielding, suitably grounded to the chassis. Use the solid, tinned copper No. 14 bus wire for making the various connections in the R.F. circuit; the heater, I.F. and A.F. circuits are wired with stranded push-back hook-up wire. All of the grounded or negative connections are brought out to a single spot on the chassis and soldered.

Aligning the Receiver

In lieu of the regular test oscillator alignment routine the following procedure may be used. Plug in the pair of coils covering the 7 megacycle amateur band and tune

in the circuit to allow the a.v.c. voltage to be cut in or out as desired. The regeneration is useful on very weak signals, especially in the 28-56 mc. region but the a.v.c. is more desirable on the lower frequencies.

The dial used on this receiver is of the precision, micrometer type and can be read to an accuracy of 1/10 of one degree. Such a high degree of accuracy is extremely useful when working on the crowded 7, 14 and 28 megacycle bands.

Set Operates on A.C. as Well as Batteries

No speaker or power unit is shown with the receiver. It is suggested that a permanent magnet dynamic speaker be used, as this will allow the set to be operated on either a 110 volt a.c. power pack or batteries.

Provision has been made for using either a doublet or straight single-wire antenna. The author used his Johnson "Q" 10-meter transmitting antenna for testing the receiver at the home location; during tests in an automobile, an ordinary fish-pole antenna gave very good results.

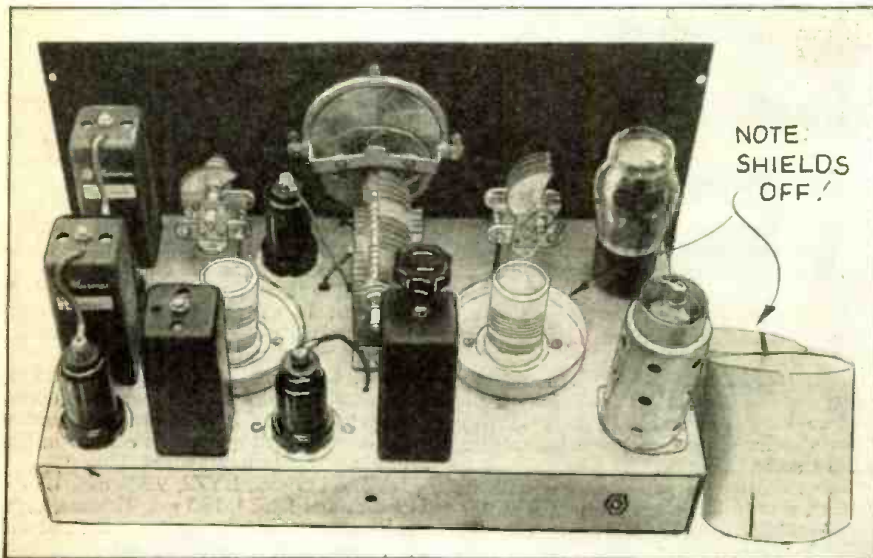

Rear View of Receiver.

for one of the "dotter" stations usually heard in this region. A weak, steady signal is best for alignment purposes. Place the a.v.c. switch in the "off" position and turn up the "gain" control full-on. Adjust the mixer and oscillator trimmers for the best signal. Now with a neutralizing tool or an insulated screw-driver, beginning with the output I.F. transformer, adjust the I.F. trimmer condenser screws for the maximum signal strength in the headphones or speaker. If the signal becomes very strong during the alignment process, reduce the input to the mixer by loosening the antenna coupling.

A.V.C. "On"- "Off" Switch

It will be noticed that the 6K8 mixer circuit may be made regenerative or not as desired. When the 2,000 ohm potentiometer is turned to the "off" position, the cathode coil is automatically short-circuited. The a.v.c. action cannot be applied to the mixer when regeneration is used so, as Fig. 1 shows, a switch has been incorporated

List of Parts

HAMMARLUND

- 1—2-gang tuning condenser, 35 mmf. per section. Type MCD-35-MX
- 1—Midget double-spaced tuning condenser, 35 mmf. Type MC-35-MX
- 1—Midget double-spaced tuning condenser, 20 mmf. Type MC-20-SX
- 8—Isolantite midget ultra-short-wave coil forms. Type CP-5-M
- 4—Octal isolantite sockets. Type S-8
- 2—Isolantite sockets, 5-prong. Type S-5
- 2—Coil shields. Type CS-3
- 2—Midget R.F. chokes, 2.1 mh. Type CH-X
- 1—Tube shield. Type TS-50
- 1—Midget trimmer condenser, 3-30 mmf. Type MEX

I.R.C.

- 1—Metallized resistor, 1/2 watt, 25,000 ohms
- 5—Metallized resistors, 1 watt, 20,000 ohms
- 6—Metallized resistors, 1 watt, 50,000 ohms
- 2—Metallized resistors, 1 watt, 75,000 ohms
- 4—Metallized resistors, 1 watt, 100,000 ohms
- 1—Metallized resistor, 1 watt, 500,000 ohms
- 3—Metallized resistors, 1 watt, 1 megohm
- 2—Metallized resistors, 1 watt, 300 ohms
- 1—Metallized resistor, 1 watt, 500 ohms
- 2—Metallized resistors, 1 watt, 2,000 ohms
- 1—Volume control, 2,000 ohms, with SPDT switch
- 1—Volume control, 5,000 ohms, with SPDT switch

(Continued on page 426)

Please say you saw it in RADIO & TELEVISION

NEW SENSATIONALLY DIFFERENT!

I CAN MAKE YOU A RADIO EXPERT

Quicker, Easier with the New
SPRAYBERRY
Personalized
TRAINING IN RADIO



Get my
FREE BOOK



You Learn by Doing Actual Experiments with Real Equipment

Don't Fail to Investigate This New Home Training Method.



I Back You Up All the Way with Close Personal Attention

I ACTUALLY SET YOU UP FOR A BUSINESS OF YOUR OWN

Here's the finest, most up-to-the-minute Radio Education available anywhere. Specially designed to give you intense, practical, quick training . . . for a money-making career in the fast moving Radio Industry. Even equips you for your own business.

TRAINING PREPARES YOU FOR JOBS AT \$40. TO \$60. PER WEEK

NO PREVIOUS EXPERIENCE NEEDED

My Training starts right at the beginning of Radio . . . unfolds each subject in a simplified, logical, understandable style. You easily learn all about Television, Electronics, Police Radio, Ship Radio, Commercial Radio Broadcasting . . . Radio Set Repair and Installation work, etc.

I SHOW YOU HOW TO MAKE GOOD SPARE-TIME MONEY . . . WHILE YOU'RE LEARNING

I supply you with valuable spare-time Business Builders which will show you how and where to get profitable Radio service jobs right in your own neighborhood. You get invaluable practical experience . . . add to your bank account at the same time.

BIG PROFESSIONAL OUTFITS GIVEN

Positively the finest equipment offered with any Radio Course is delivered to you as a regular feature of Sprayberry Training. Enables you to set up your own home laboratory.

The Sprayberry Course Is Sold Under an Iron-Clad, Money-Back Agreement.

SPECIAL SERVICEMAN'S COURSE

I offer advanced Training for those already in Radio. Complete details of this advanced Course and fundamental Course, features, etc., fully described in my new 44-page FREE BOOK. Send for your copy today.

RUSH THIS COUPON FOR BIG FREE BOOK

SPRAYBERRY ACADEMY OF RADIO
F. L. Sprayberry, President
145-L University Place, N. W.
Washington, D. C.

Please send me FREE copy of "HOW TO MAKE MONEY IN RADIO".

Name Age

Address

City State

(Mail in envelope or paste coupon on postcard)

The Terminal Radio Preselector

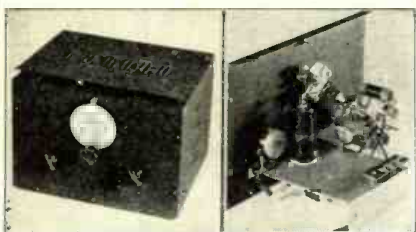

You'll hear stations you were never able to hear before, with the new Terminal Preselector!

Here's what the Terminal Radio Preselector does:

- Provides plenty of r.f. gain to clearly hear inaudible, weak signals.
- Improves selectivity to substantially reduce the blocking effect of strong local stations.
- Boosts signal-to-noise ratio. Increases the incoming signal.
- Covers five amateur bands with efficient band-switch.
- Makes possible 10 meter reception on receivers covering 20 meters.
- Small power requirements easily obtained from receiver by means of 4 wire cable provided.

You NEED the Terminal Radio Preselector for present day short wave reception!

Terminal Radio Preselector, completely wired and in cabinet, less tube..... \$14.95

Type 1851 tube..... 2.10

Type 6K7 (can be used in place of 1851)... .81

Browning BL-5H r.f. tuning unit, as used in above..... 1.85

Cabinet, chassis and panel only, as used in above..... 2.25

Write for our free monthly bulletin!

We carry complete stocks of everything in radio. Mail orders are promptly and accurately filled. We ship to all parts of the world.

Dept. RI Cable Address: TERMRADIO

TERMINAL
Radio Corporation
80 CORTLANDT STREET, NEW YORK, N. Y.

WHY AMATEURS PREFER BUD MIDGET CONDENSERS

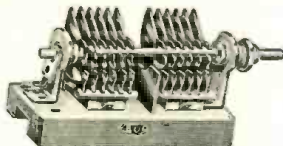

Double spring on rear bearing gives perfect contact and noiseless operation. Precision built to give "THE BEST FOR LESS." Send 10c for Log & Data Book SW118, or FREE descriptive literature SWC118.

BUD
BUD RADIO, INC.
CLEVELAND, OHIO

WE HAVE *The* RADIO YOU WANT



How would you like to save up to 50% on Nationally advertised Radios, such as Stromberg Carlson, Philco, RCA, Zenith, G. E. etc., etc. for home, farm and auto, over 400 models to choose from. Also hundreds of electric appliance items for the home. Write today for the new 1938 giant catalog FREE.

MODELL'S Dept. 60 Cortlandt St., N.Y.C.

Short Wave Listening Tips

(Continued from page 403)

heard the transmitter on or near 15.12 mc. and also was advised that two more frequencies would be added this year. Further information will be furnished later. SPW has a new veri card done in tan, brown and blue.

I2R04, 11.81 mc., IRF, 9.83 mc., IQY, 11.676 mc., and ICC, 6.355 mc., are being used in Italy in the broadcast of programs. Two new frequencies, I2R05, 15.3 mc. and I2R06, 17.82 mc., are heard at times. The last named 2 kw. transmitters are "keeping the place" in the 19 and 16 meter bands until the new Imperial transmitting station is completed. This station is now under construction. The 15.3 mc. frequency is usually heard between 7:30 and 9:30 p.m. and the 17.82 frequency in the morning and not later than noon.

CSW4, 11.84 mc., CSW2, 11.04 mc., and CSW3, 9.94 mc., were the originally assigned calls and frequencies for Portugal. From reports and available information they are now using 9.737 and 11.04 mc. with the calls CSW5 and CSW7, respectively. On account of meeting interference on 9.737, they have been shifting between 9.67 and 9.74 mc.

Radio Semanal, a Portuguese publication, shows Ponta Delgada, 3.599 mc., CS2WZ, as on the air daily from 5:30 to 6:30 p.m. It is assumed that the above station was CT2AJ, 4.002 mc., formerly listed as Ponta Delgada, Island of St. Michael, Azores.

HAS6, 21.68 mc., Budapest, is a new station in Hungary.

RKI, 15.08 mc., RNE, 12.06 mc., and RAN, 9.6 mc., are being used on English broadcasts as well as for broadcasts in other languages from Moscow, which advises that they have two frequencies, 15.04 and 15.080 mc., with call RKI. They are now using the latter, which explains the shifting at times on this band. It is also noted that RNE is listed by them on 50 meters or 6. mc. This station is heard on occasional broadcasts.

RNE, 12.06 mc., Moscow, broadcasts Morse code by Soviet News Agency daily, 12.20 to 1:10 p.m. and 7:15 to 9:15 p.m. Reports solicited by Department of Morse, Radio Centre, Moscow.

Greece has not as yet come out with its reported new 10 kw. short wave transmitter.

LZA, 14.970 mc., Sofia, Bulgaria, called Radio Sofia, advises they are not broadcasting on short waves and have not been for some time. The only broadcasts coming out of Bulgaria are on 352.9 meters.

OER2, 6.072 mc., and OER3, 11.801 mc., Wien, are still being operated according to

word from Germany, and are relaying programs of Reichsender Wien, although heard but occasionally.

OER5, 15.190 mc., Wien, is under construction.

DJK, 21.64 mc., DJJ, 21.565 mc., DJG, 17.815 mc., and DJH, 17.845 mc., Zeesen, Germany, have been put into service and may be heard on broadcasts of programs from Berlin.

YUA, 6.1 mc., Belgrade, Yugoslavia, has not yet reported on its new facilities, if to be installed. When heard on occasional broadcasts on 10.29, 11.855 or 15.11 mc. to America, YUA transmits the program and Germany relays over DZC, DJP or DJL. YUA will doubtless be heard since W9XF, Chicago, has left the air.

OFH, 6.12 mc., OFE, 9.5 mc., and OFD, 11.78 mc., are the calls and frequencies of transmitters broadcasting from Finland and located at Lahti.

The power has recently been increased from 2 to 10 kilowatts. While the transmitters for 15.19, 17.8 and 21.55 mc. are actually under construction, they will not be completed and put in operation for some months. Call letters for these stations have not been assigned. Reports should be sent to The Finnish Broadcasting Company, Helsinki, Finland, and not to Lahti. OFE has been heard by many listeners.

Denmark is being heard on a new frequency near 17.93 mc. broadcasting interesting programs of music and song and leaving the air about 8:45 p.m. Copenhagen has broadcast over OZH, 15.165 mc., OZG, 11.805 mc., and OZF, 9.52 mc., but heard mostly over the last named frequency, which appears to be working but occasionally at present. The call and exact frequency of the broadcast heard near 17.93 mc. has not as yet been learned.

SM5SX, 15.155 mc., Stockholm, Sweden, broadcasts from 11 a.m. to 5 p.m. weekdays and 9 a.m. to 5 p.m. on Sundays.

SBP, 11.705 mc., Motala, weekdays 1:20 to 2 a.m.; 11 a.m. to 4:15 p.m.; Sundays 3 a.m. to 4:15 p.m. Broadcasts to America Wednesday and Saturday 8 to 9 p.m.

SBO, 6.065 mc., Motala, daily 4:15 to 5 p.m. and broadcasts to America Wednesday and Saturday from 8 to 9 p.m., unless SBP is used. (All quotations of time in this article are Eastern Standard Time.)

LYZ, 6.125 mc., LYZZ, 9.523 mc., LYZ3, 11.9 mc., and LYZ4, 15.3 mc., Kaunas, Lithuania, are not in broadcast service and are as yet only being projected.

Radio telephone tests are made at irregular intervals by the transmitter, LYR on 9.315 mc. or 32.21 meters. This information from the Chief of Radio Section, Di-

(Continued on page 445)

NEW "STREAMLINER" HAS MANY FEATURES

The new Sargent "Streamliner '39" receiver has many attractive features. The volume control varies the input to the audio tubes, thereby maintaining R.F. sensitivity. The a.c. line switch is also on this control. Headphones may be plugged in for DX or late night reception. The set's automatic volume control system is designed to prevent or minimize overload distortion on powerful, nearby stations, and is particularly effective on phone and broadcast. The c.w. switch is turned "on" for telegraph reception only. There is also a wave-band change switch.

This article was prepared from data supplied by courtesy E. M. Sargent Co.

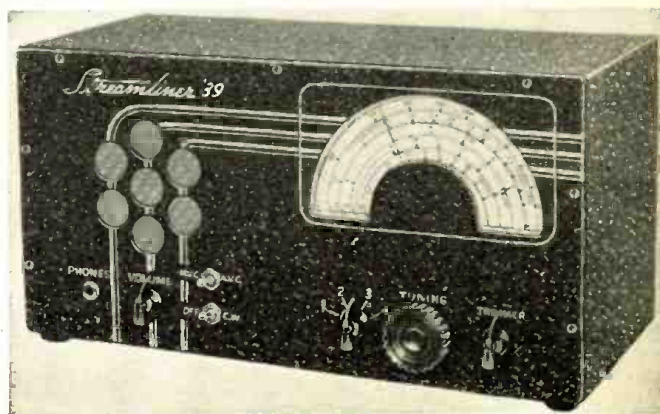

110 Volt Direct Current TRANSMITTER

(Continued from page 421)

the meter jack and ground another jack (J4) has been wired. This jack which can be seen in the photo on the rear side of the chassis is the keying jack, into which a telegraph key is plugged by means of a phone plug and two-wire cable. Keying in the amplifier cathode was found to be the most desirable method to use with this particular transmitter.

For frequency control a variable frequency crystal was used and allowed an appreciable change in frequency to escape local QRM and also to aid in shifting one's frequency for spot-frequency operation in traffic nets.

The chassis used is standard and measures 17" x 10" x 4". The oscillator is of the "tri-tet" type. Tuning the cathode circuit is

not at all critical, the same setting of the cathode condenser (C1) holding good for the entire amateur band in use. This led to the use of a tapped cathode coil and a condenser that could be set once and then forgotten. (More details concerning this part of the circuit will be given in Part 2 of the article next month.)

A 60 ma. (2-volt) pilot light bulb serves to indicate when the current to the crystal is too high, and provides a valuable aid in tuning the oscillator for optimum output. The oscillator is inductively coupled to the amplifier. The amplifier employs four 25L6G tubes, connected in push-pull parallel. (Details concerning the connections of this stage will be given in Part 2 of the article, as well as hints on neutralizing and "tuning up" the transmitter, etc.)

Coil Data

BND L-2	L-3, L-4	L-5
80 30 turns No. 18 enam. 1½" diam. close wound	each 10 turns No. 28 DCC close wound ¼" from each end of L2	30 turns No. 18 enam. 2¼" diam. close wound
40 16 turns No. 18 enam. 1½" diam. close wound	each 6 turns No. 24 DCC close wound ¼" from each end of L2	14 turns No. 14 enam. 2¼" diam. wound to length of 2"
20 10 turns No. 18 enam. 1½" diam. length 1"	each 4 turns No. 24 DCC close wound ¼" from each end L2	10 turns No. 14 enam. 1½" diam. length 1½"
L-1—35 turns No. 18 enam. close wound, tapped at 5 turns and at 14 turns, wound on 1½" diam. form.		

Parts List

- BUD**
1—Chassis 10x17x4" No. 641
5—Octal wafer sockets No. 390
3—5 prong wafer sockets No. 114
1—6 prong wafer socket No. 363
3—6 prong coil forms No. 310
2—5 prong 2½" diam. coil forms No. 735
2—5 prong coil forms 1½" diam. No. 126
2—100 mmf. tuning conds. No. 905; C-1; C-4
1—Split stator tuning cond. 100 mmf. each section No. 911; C-6
2—6 mmfd. neutralizing conds. C-N No. 567
2—R.F. chokes. 2.5 mh. No. 920, RFC-1
1—R.F. choke 2.5 mh. 250 ma., No. 876; RFC-2
- TRIPLETT**
1—Model 326 2" square D.C. Milliammeter 0-10 MA
1—External shunt for 100 MA R2
1—External shunt for 250 MA R4
- BLILEY**
1—Variable frequency crystal, Type VF-1
- CORNELL-DUBILIER**
1—16 mfd. 200 volt electrolytic condenser C-7
3—.002 mfd. mica postage stamp condensers C-3, C-8, C-6
2—.006 mfd. mica postage stamp condensers C2, C9
- I.R.C.**
1—100,000 ohm ¼ watt R-1
1—25,000 ohm 1 watt R-3
- CROWE**
2—2¾" dials with vernier scales, type No. 294
- YAXLEY**
1—Phone plug No. 75
4—Type A-2 midget jacks (closed circuit) J1, J2, J3, J4
1—6 point rotary switch No. 1316L
- NATIONAL UNION RADIO CORP.**
4—25L6G tubes
1—25L6 tube
- CORNISH WIRE CO.**
¼ lb. No. 14 enam.
¼ lb. No. 18 enam.
15 ft. No. 28 D.C.C.
20 ft. No. 24 D.C.C.
- MISCELLANEOUS**
1—SPST toggle switch SW-2
1—DPST toggle switch SW-3
2—R.F. chokes—RFC-3 (See text.)
1—60 ma. Pilot light bulb (B)
1—Porcelain socket for 60 ma. bulb

PART II—Next Issue.

Answers to QUIZ on page 397

- c—He did it with his little radio
- c
- b & d
- Ab Be Ca Df Ec Fd
- d
- b & c
- ese means East-southeast
- b
- d
- c
- d
- d & e ("That's all" & A box for broken or pied type)
- b (Caustic Soda) Edison cells
e (Sulphuric Acid) Lead cells
- d
- f
- e
- a & c
- b
- c (Transcontinental & Western Airways)

- d
- c
- d
- AcF BeE CaD DbA EfC FdB
- a4 b5 (octal) c7 d6 e None (Mogul screw base) f6
- a

CORRECTION

Following correction should be noted in connection with the article on "5-Meter Super-regen.", page 356, October issue. The end of the 50,000 ohm potentiometer super-regen. control connected to the 0.5 mf. condenser should also be connected to "B-". The resistance between grid and plate of the detector section of the 6C8G should be marked 15 megohms instead of 0.5 meg. Also the section of the 6C8G, having both its plate and grid leads at the base of the tube, is the detector section and not the amplifier section as shown in the diagram. The latter two are correctly mentioned in the article.

For a Genuine

THRILL!

BUILD THE BROWNING 83

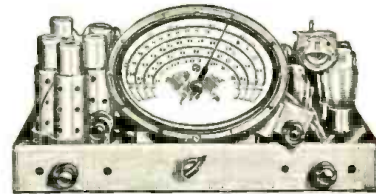

THE HIT SET OF THE SEASON

For the Discriminating professional—for the amateur experimenter—the new Browning 83 fills the bill. Here is a kit set which can be constructed and aligned with nothing more than a soldering iron, a pair of pliers, and a screw driver. The completed job is a high quality receiver whose performance will amaze you.

FEATURES

- Extremely high signal-to-noise ratio essential for DX reception.
- Band pass IF amplifier provides adequate selectivity without "clipping" side bands.
- The four band BL-1 Tuner covers continuous frequency spectrum from .54 to 22 mc.
- Generous overlap on all bands prevents skips and dead spots.
- Sensitivity less than 1 microvolt on all bands.
- High fidelity audio system provides genuine program enjoyment.
- Visual tuning indicator.
- A.V.C.—Manual control of both IF and audio gain.

Write for Brochure

AMATEURS

Your problems solved at last with the new BL-5 series. Three band-switching Tuners covering the 10- 20- 40- 80- and 160-meter bands with complete band spread. Use the BL-5G and BL-5P Tuners as the foundation of an all-band E.C. Exciter with bed rock stability. Note cannot be told from crystal. 35 watts output. Double to 5 meters in output stage if desired. Use the BL-5H to construct a simple and efficient receiver, a preselector, a signal generator or a host of other gadgets needed in every shack. The quality—the highest obtainable. The price—amazingly low. Leading distributors now have in stock the new Browning Laboratories Amateur Tuners.

Write for BL-5 Bulletin

BROWNING LABORATORIES, INC.
WINCHESTER, MASS.
EXPORT DEPT., 461 4th AVE., N. Y. C.



The AMPERITE ACOUSTIC COMPENSATOR

gives you
HIGH OR LOW PITCH

WITH THE SAME MICROPHONE
With the flip of a finger you can now (1) lower or raise the response of the microphone. . . (2) adjust the microphone for most desirable response for close talking or distant pickup. . . (3) adjust the system to any "taste", room condition, or equipment.

MODELS RBHK, RBMK, with Acoustic Compensator, frequency range 40 to 11000 cps, output, -65 db., complete with switch, cable connector and 25' of cable. \$42.00 LIST

NEW! MODEL RSHk (hi-imp): RBSk (200 ohms) Frequency range 60 to 8000 C.P.S. Output -68db. Chrome or Gun-metal \$32.00 LIST

NEW LOW PRICE CONTACT "MIKE"
Model SKH (hi-imp), SKL (200 ohms) \$12.00 LIST
Model RAH-RAL, excellent for speech and music. Reduce feedback. \$22.00 LIST

Write for Complete Illustrated Bulletins and Valuable Sales Heps.

AMPERITE 561 BROADWAY, N. Y. Cable Address: Alkern, New York

AMPERITE Velocity MICROPHONE

My Creed . . .

To give you specialized personal service of genuine value that is not available from other jobbers. To finance all my time sales myself so that I can sell all receivers, transmitters, and parts to you on terms arranged to suit you with less interest cost and more convenience.

To take your equipment in trade at a fair value. To allow you to try any receiver for ten days without obligation and to cooperate with you in every way I can to see that you are entirely satisfied.

Compare Bob Henry's Terms with Others

Model and Receiver	Cash Price	Down Payment	12 Mo. Payment
The New NC100A	\$120.00	\$24.00	\$8.48
NC80X and NC81X	99.00	19.80	6.99
Improved NC101X	129.00	25.80	9.11
The New RME-70	138.60	27.72	9.79
Brefing 14AX	99.00	19.80	6.99
The NEW Sky Buddy	29.50	5.90	2.08
Sky Champion	49.50	9.90	3.49
Sky Challenger II	77.00	15.40	5.44
Super Skyrider	99.00	19.80	6.99

Also Super Pro, HRO, PR15, Brefing 9, Sargents, others.

Similar terms on Harvey, Hallcraft, RCA, RME, Temco transmitters and National, Thordarson, U. T. C., Progressive, Utah, Stancor kits.

All orders and inquiries attended to by Bob Henry, W9ARA; an active amateur for fourteen years; graduate E.E. from M.I.T.; owner of Henry Radio Shop selling short wave supplies for ten years. Your inquiries invited.

HENRY RADIO SHOP
211 North Main Street Butler, Missouri

5-Band One-Tube Preselector

(Continued from page 409)

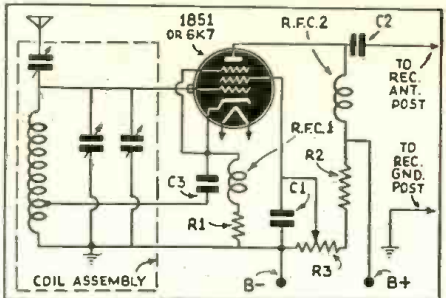

Hook-up of Preselector

selector, shown as the lead to the antenna post of the receiver, to the grid of the receiver's converter tube. If the grid is located atop the tube, hook-up is greatly simplified.

List of Parts

- 1—BL-5H Browning tuner
 - C1—01 400 volt tubular (Cornell-Dubilier)
 - C2—00025 mica (Cornell-Dubilier)
 - C3—01 400 volt tubular (Cornell-Dubilier)
 - R1—300 ohm, 1 watt (IRC)
 - R2—50,000 ohm, 1 watt (IRC)
 - R3—25,000 ohm potentiometer (IRC)
 - RFC1, RFC2—2.5 mh. r.f. choke (National)
 - 1—type 1851 or 6K7 RCA tube
 - 1—RCS8 tube socket (Amphenol)
 - Terminal special cabinet, chassis and panel
 - 1—Terminal vernier dial
 - 3 ft. four-wire cable
 - 3—dial knobs
 - Miscellaneous hardware
- This article has been prepared from data supplied by courtesy of Terminal Radio Corporation.

5 to 50 Meter Superhet.

(Continued from page 423)

- 1—Volume control, 500,000 ohms with SPST switch
 - 1—Volume control, 500,000 ohms. No switch
- AEROVOX**
5—Dual 0.1-0.1 mf. paper dielectric condensers, 600 W.V.
6—Paper dielectric condensers, 0.05 mf. 600 W.V.
3—Paper dielectric condensers, 0.01 mf. 600 W.V.
2—Mica condensers, 0.0001 mf.
1—Mica condenser, 0.001 mf.
1—Mica condenser, 0.0005 mf.
2—Electrolytic condensers, 25 mf. 50 W.V.
2—Electrolytic condensers, 50 mf. 25 W.V.

- MEISSNER**
1—I.F. transformer, iron-core, input, 1500 kc.
1—I.F. transformer, iron-core, interstage, 1500 kc.
1—I.F. transformer, iron-core, output, 1500 kc.
1—Beat-oscillator transformer, 1500 kc.
2—Spring-mounting bakelite sockets, 8-prong octal type

- RAYTHEON**
1—6K8 metal tube
2—6S7 metal tube
1—6R7 metal tube
1—6F8G glass tube
1—6F6G glass tube
1—5Y4G glass tube (for power unit)

- BUD**
1—Steel cabinet, 7x14x8 inches, with front panel
1—Steel chassis—7x13x2 inches

- BRUSH**
1—Pair type "A" crystal headphones

- CROWE**
1—Precision micrometer dial, 270 degrees, for clock-wise tuning condenser, 1/4" shaft
6—Pointer knobs

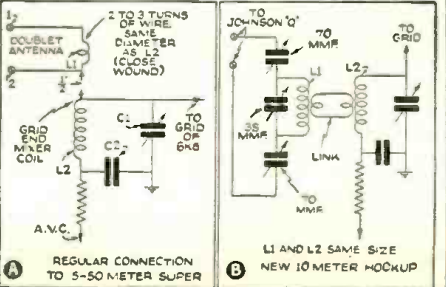

"Doublet" and 10 Meter Hook-ups

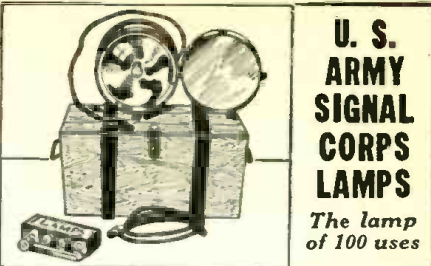

U. S. ARMY SIGNAL CORPS LAMPS
The lamp of 100 uses

- Scout Signalling
- Night Bowling Alleys
- Trailer Lamp
- Night Motor Boat Races
- Auto, Truck and Trailer Camps
- Tractor Light
- Camp Light
- Barnyard Lighting
- Night Fishing
- Radio Shack
- Bungalows
- Picnics, etc.



Large size—12 1/2" wide, 5 3/4" deep, 1 1/2" high, including socket, fitted with 10" silver plated reflector (no glass, nothing to break). Packed in portable wooden carrying case, with hinged cover, hasp and handles. Every case contains weatherproof extension cord and plus, 2 extra bulbs, telegraph signalling key and 16 page U.S. Army Instruction Manual. Shipping weight 18 lbs. Price \$25.00
F.O.B. N. Y. 3 for \$10.00

Large lamp, with bulb, but without case and extra fittings. \$1.95 3 for \$5.00
Small size—8" wide, 5" deep, 1 1/2" high including socket. Lamp furnished with a volt. bulb for A.C. current. One extra bulb furnished free. Additional bulbs, 15c each. Packed in a corrugated carton. Shipping weight 2 lbs. Price \$1.95 3 for \$5.00
(Cost the Government about \$10.00) F.O.B. N. Y.

These lamps will make an attractive souvenir of the World War for your Club, Motor Boat, House, Den, Radio Shack or Country Home. They will also be an acceptable gift to any of your friends.

An Accurate, Eight Inch White Wood SLIDE RULE With A, B, C, D, C1 and K Scales

Features
Nickel Silver Framed Indicator with integral friction springs. Scales calibrated directly on well-seasoned wood will retain accuracy regardless of temperature or humidity changes. Instructions and illustrations of primary operation clearly printed on back side of rule for ready reference or teaching. Each rule in a durable pocket carrying case for convenience and protection.

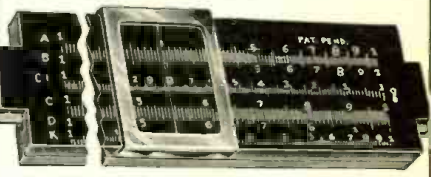

The extremely low price of these slide rules and their absolute accuracy makes them ideal for the student as well as the working man who has always wanted to learn to use a slide rule.

Price 25c plus 5c postage.
20 Page Book of Instructions for using a slide rule, 5c each, plus postage
36 Page Book of 300 Examples and Answers, 10c each, plus postage.



STOPPANI COMPASS

A Precision Instrument made in Belgium. Purchased by the U. S. Government at more than \$30.00 each. Ideal for Radio Experimenters Laboratory, also may be used as a Galvanometer for detecting electric currents in radio circuits. Rubly leveled, solid bronze. 4 inches square, fitted in a hardwood case. Also used by hunters and surveyors.
Our price prepaid \$4.50 each

Send for catalog containing full descriptions of these items and many other unusually interesting and worthwhile merchandise.

GOLD SHIELD PRODUCTS
Dept. RT-11 350 Greenwich St. New York

Cathode-Ray Monitor

(Continued from page 413)

The output of the sweep oscillator is connected to the grid of a type 6J7 amplifier which increases the sweep voltage so that only a small portion of the condenser charge curve (the straight part) is used. The output of the horizontal amplifier is connected to the horizontal plates of the C.R. tube through a strap on the back of the case (see Fig. 3), so that the sweep circuit and amplifier can be eliminated when they are not needed—for example, in monitoring the modulated output of a transmitter against the signal input.

The vertical amplifier, also, uses a 6J7 tube connected in a similar manner to the horizontal amplifier, through a strap on the back of the case to the vertical plates of the 902 tube. The input of the vertical amplifier, however, is arranged so that a 465 kc. signal can be applied (through the I.F. transformer) or lower frequency inputs can be connected by throwing the single-pole double-throw switch to input terminal No. 1.

Both the vertical and horizontal amplifiers are equipped with input volume controls for controlling the amount of deflection vertically and horizontally, with widely varying input signals. The 885 tube also has an input control which varies the amount of synchronizing voltage applied to the sweep tube. The latter voltage should be kept as low as possible consistent with stability in "locking" the signal in place on the screen.

It is well to say here—for those who might not be cautious—that the voltages developed under certain circumstances in this unit are dangerous and that even circuits of normally low potential can carry high voltage. So always turn off the power before making adjustments or changes.

Testing the Instrument

The instrument is then ready for test. Turn all potentiometers to their minimum position. Then put the tubes in their sockets and advance the intensity control and focus to their mid-points, after allowing the heaters time to come up to normal operating temperature. Then slowly advance the intensity control until a faint green spot or circle appears. Next adjust the focus till the spot is small and sharply defined. Keep the intensity control as low as possible consistent with a visible image, to avoid burning the screen of the 902 tube. Next advance the various other controls—the horizontal amplifier control and the sweep controls till a horizontal line appears in place of the spot. Then turn the vertical amplifier control all the way on. Turn Sw. 2 to the closed position and Sw. 3 to input terminal No. 1. Then by touching terminal No. 1 with your finger, irregular patterns should appear, which vary with the settings of frequency and amplifier controls.

If the spot obtained when the sweep is turned off is not in the center of the screen of the 902, correction of the centering is necessary. Because of lack of space and to reduce cost to a minimum, centering controls have been omitted. However, correction can easily be obtained by placing a small bar or horse-shoe permanent magnet inside the cabinet at a point best located by "cut and try." Very little magnetic strength is needed, so a tiny magnet will suffice.

Place a few ventilating holes in the cabinet.

Application

MODULATION MEASUREMENT may be made by applying the sweep to the horizontal plates and connecting a coil (of about three turns on a diameter of 2") between

A New Sargent Communication Super-Het!



Sargent Model 51

It is a real pleasure to announce a receiver of the calibre of Model 51. Although our receivers already enjoy a reputation for correct, careful design, we have surpassed any previous receiver in the rugged, lifetime construction of Model 51. Built to last—and of the best obtainable materials—Model 51 will give stable operation, dependable service for years, in locations that are inaccessible, repair parts hard to obtain. Model 51 is the receiver for dependability.

Regenerative input, introduced in our Model 21 and outstandingly successful, is used on all bands on 51. Individual panel-operated trimmers on R.F. and detector stages insure perfect alignment at all times. 10 and 20 meter band performance is outstanding. High sensitivity, very low noise level—a pleasant surprise to listen to.

For extreme DX the regenerative input adds that extra punch that brings those very weak signals up to audibility. For maintaining a communication schedule, Model 51 has stability equaled by few receivers. A receiver you will be proud to own.

Look At These Features

- Regenerative Input, all Bands
- High 10/20 Meter Efficiency
- 10 New Type Glass Tubes
- Equivalent Performance 13 Tubes
- Isolantite Insulation
- Shadow Tuning
- Iron Core I.F.
- Band Spread
- C.W. Pitch Control
- R.F. and Det. Panel Trimmers
- Break-In Switch
- Headphone Jack
- R.F. Input Control
- Manual Volume or AVC
- Tone Control
- Push-Pull Audio
- 8" Jensen Speaker
- A.C.-D.C. Circuit
- Full Wave A.C. Rectification
- Both Power Lines Filtered
- Lifetime Filter Condensers.—no Electrolytics
- Shielded, Moisture-proof Bypasses
- Insulated, Moisture-proof Resistors

Model 51 Net Prices

Model 51-AK, 9.5 to 550 meters, 110 volts AC-DC **\$157.00**
 Model 51-MK, 9.5 to 3750 meters, 110 volts AC-DC **\$175.00**
 6 roll Battery Model on special order. Prices include I.C.A. tubes, speaker power, ready to go.

Write for Complete Data

E. M. SARGENT CO.

Cable Address "EMSCO"

212 9th Street Oakland, Calif.

The New Premax Corulite

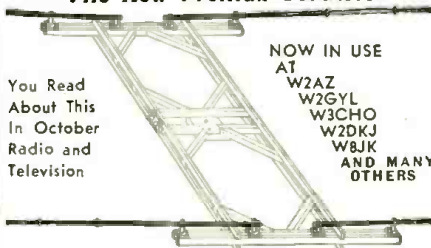

You Read About This In October Radio and Television

NOW IN USE AT

W2AZ
W2GYL
W3CHO
W2DKJ
W8JK
AND MANY OTHERS

ROTARY BEAM ANTENNA

FOR 10 AND 20 METERS

Kit contains 4 17½' fully telescoping Corulite elements, 8 combination mounting brackets and soldering lugs, complete drawings, and comprehensive bibliography of arrays, lines, etc. See your jobber or write direct for bulletins of kits.

Vertical Steel Radiators

Fully Telescoping and Adjustable

- Quick, easy to install
- No long pipes to handle
- Simply erect six-foot unit and extend to height desired
- Special design 25,000 volt insulator similar to 800 foot tower type.

Made of steel tubing in carefully designed sizes to permit telescoping to 6-foot unit, yet extending any height up to 34-ft. for 20-meters. Six sections with 3-point locking joints, all heavily copper plated for minimum R.F. resistance.

10-Meter radiator is of three sections, employing the famous Corulite Elements—extending to 17 feet. Ask your jobber or write direct.

PREMAX PRODUCTS

DIV. CHISHOLM-RYDER CO., INC.
3923 HIGHLAND - NIAGARA FALLS, N. Y.

COMPLETE DYNAMIC TESTING

Direct, quick, practical instruction for complete 14-point check of all receivers with cathode ray, easily mastered by anyone who can read a circuit diagram. Without it, you're behind the times! Get your copy TODAY!

FREE WITH ANY C-B INSTRUMENT

Clough-Bregle Co., Chicago, Ill., U.S.A.



"A MILLION DOLLAR BABY!"

THAT DOES A MAN-SIZED JOB

That's the way servicemen are referring to the new Sprague ATOMS! For ATOMS (midget dry electrolytics) have all the quality of a real "million dollar baby." They're backed with all the engineering resources of the world's largest manufacturer of quality condensers. They're built better, more scientifically than larger old-style units they're designed to replace. And they're selling like hot cakes among those who know them best—wherever the demand is for really good condensers at rock-bottom prices.

SAVE TIME • MONEY • SPACE

Made by an exclusive Sprague etched-foil process, ATOMS are available in all standard capacities including DUAL COMBINATIONS. You save real money. If you haven't tried them yet—TRY THEM NOW!

SPRAGUE PRODUCTS CO.
North Adams, Mass.

SPRAGUE ATOMS
"Mightiest Midgets of All"...

BLILEY CRYSTALS
10-20-40-80-160 Meter Bands
Now \$3.35 up.
Bliley Electric Co., Erie, Pa.

OUR NEW SHORT WAVE LISTENER MODEL THE DOERLE MODEL D39

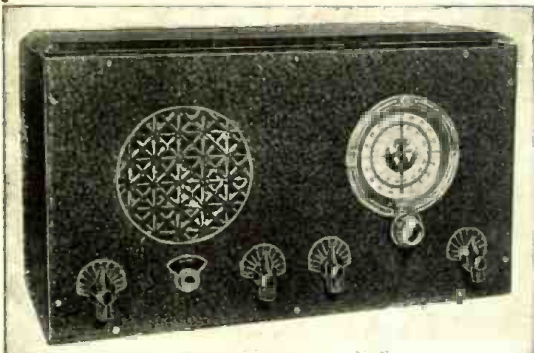

THE OUTSTANDING VALUE FOR 1939

Model D39 designed to have all the desirable features of our larger models but at a price within reach of all.

Uses a 6k7g tube as screen grid tuned R.F. amplifier, a 6j7g tube as tuned electron coupled screen grid regenerative detector, a 76g tube as a driver audio which is fed into the popular and efficient 2516g beam power audio output tube which delivers over two watts of undistorted audio power to the dynamic speaker.

A 25z6g tube is used as the rectifier and is fully capable of supplying the power requirements of the set. A type k92a tube is used as the ballast to drop the filament supply to the proper voltage.

Separate controls for volume, tone, regeneration and R.F. gain are used.

A headphone jack is incorporated to permit the use of phones when desired which automatically cuts off the speaker when phones are plugged in.

A carefully designed circuit is used so as to give maximum efficiency and output. The built-in power supply is well filtered to eliminate hum. Filter networks are incorporated in the audio amplifiers and a tuneable hum filter removes all traces of this condition common in many short wave sets. Operates from regular 110 volt house current. Covers from 9 to 600 meters with no skips which includes the standard broadcast band and all short wave bands except the amateur 6 meter band. Send stamp for circular D39.

Sold complete ready to use nothing else to buy with all tubes and coils 9 to 600 meters wired and tested

\$19.95

All parts needed to build and wire but less tubes, with all coils, cabinet, chassis and diagram. May be obtained in battery model or 220 volt model at same prices for portable or foreign use.

\$14.95

FLASH! SEND 10¢ FOR OUR NEW CATALOG containing **CIRCUIT DIAGRAMS**, and complete information on over 25 different types of short wave receivers and transmitters from \$2.50 and up. This catalog is chock full of schematic and picture diagrams, look ups and short wave information. A book in itself. Well worth the dime, which will be refunded with your first order.

OSCAR B. KUSTERMAN 68 Barclay Street, Dept. 11
New York City



TRANSOIL

for transmitting

HIGHEST QUALITY OIL CAPACITORS

Ask for new complete
Transmitting Catalog
describing

TRANSOIL—SOLAREX—TRANSMICA

SOLAR MFG. CORP.  599 BROADWAY,
NEW YORK CITY

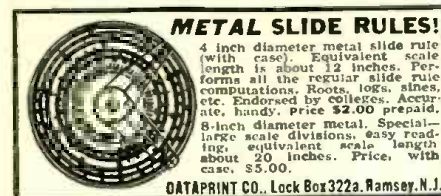

METAL SLIDE RULES!

4 inch diameter metal slide rule (with case). Equivalent scale length is about 12 inches. Performs all the regular slide rule computations. Roots, logs, sines, etc. Endorsed by colleges. Accurate, handy. Price \$2.00 prepaid. 8-inch diameter metal. Special—large scale divisions, easy reading, equivalent scale length about 20 inches. Price, with case, \$5.00.

QATAPRINT CO., Lock Box 322a, Ramsey, N.J.

Join the **SHORT WAVE
LEAGUE**. See Page 442.

Cathode-Ray Monitor

(Continued from preceding page)

the vertical deflecting plate and the ground terminal on the oscillograph unit. The strap on the vertical terminal is first removed. The coil should be placed somewhere near the tank coils of the transmitter, depending on the transmitter's power. A twisted pair will serve to connect the coil to the vertical plates.

When a constant tone is used to modulate the rig, the pattern may be held stationary for observation and any overload or distortion noted as the input voltage to the transmitter (at the input to the modulator) is varied. The percentage of modulation is calculated from the following formula:

$$\text{Modulation \%} = \frac{A-B}{A+B} \times 100$$

The ratio of A to B is measured from the image shown in Fig. 4.

The same method can be used for continuous monitoring of the transmitter during operation, except that the image will not be stationary since the modulation percentage will be continually varying. However, the average and peak percentages can be observed with reasonable accuracy.

TRAPEZOIDAL PATTERN METHOD—The most common way to monitor a transmitter is the method which produces wedge-shaped patterns, such as those shown in Fig. 5. In this method, a coil like that used above is connected to the vertical plates, but instead of using the horizontal linear sweep, the signal at the input of the modulator is applied to the horizontal plates by opening the horizontal strap and connecting the modulation signal to the horizontal plate and oscillograph ground. By the shape of the pattern obtained, a complete analysis of the transmitter may be made. The trapezoidal shaped images

in Fig. 5, which were taken on a modern 150 watt ham transmitter, illustrate the various facts that can be gleaned from the wedge-shaped forms.

The percentage of modulation can be obtained from the same formula as that used before, where A is the large dimension of the trapezoid and B is the small end.

RADIO RECEIVER MONITORING—This method is similar to the first method, except that the vertical input is fed from the station receiver into input terminal No. 2 and ground, instead of being picked up by a feeler coil. The I.F. coil in the oscillograph monitor is tuned to resonance with the I.F. amplifier of the receiver and is connected between the plate and chassis of the last I.F. tube in the set. The image shape obtained will be similar to that shown in Fig. 4, though some variation due to phase shift and tuning characteristics in the receiver may be encountered.

OSCILLOSCOPE MEASUREMENTS—This monitor is a complete oscilloscope which may be used for all the analysis tasks possible with any oscilloscope.

List of Parts

HAMMARLUND

One I.F. transformer (Frequency to match I.F. of receiver)
One isolantite octal socket for 902 tube

R.C.A.

One 902 cathode-ray tube
Two 5Z4 tubes
Two 6J7 tubes
One 885 tube

SPRAGUE

One dual-8mf. electrolytic cond. 475 W.V., type SR-88
One 8 mf. electrolytic cond. 450 W.V. type TM-8
Four 0.1 mf. 600 W.V. paper cond.
Three 0.25 mf. 600 W.V. paper cond.
One 0.5 mf. 600 W.V. paper cond.
One 10 mf. 25 V. dry electrolytic cond.
One 0.025 mf. mica cond.
One 0.005 mf. mica cond.
One 0.001 mf. mica cond.
One 0.0005 mf. mica cond.
One 0.05 mf. 400 V. paper cond.
Two 0.006 mf. mica cond.

IRC

One resistor, 0.1 meg. 2 watt
Two resistors, 0.1 meg. 1 watt
Two resistors, 2 meg. 1/2 watt
Two resistors, 0.25 meg. 1/2 watt
One resistor, 25,000 ohms, 1/2 watt
One resistor, 1 meg. 1/2 watt
One resistor, 0.3 meg. 1/2 watt
One resistor, 300 ohms, 1/2 watt
Two resistors, 1,000 ohms, 1/2 watt
One resistor, 25,000 ohms, 2 watt
One resistor, 40,000 ohms, 5 watt, type DG
One resistor, 650 ohms, 1/2 watt

PAR-METAL

One aluminum chassis, 9"x4 1/2"x1 1/2" deep

CROWE

One cabinet, type 245
Five knobs, type 286
Two knobs, type 284

AMERICAN RADIO HARDWARE

Five binding posts, type 147, with insulating washers for 1/32" panel

EBY

Four bakelite wafer octal sockets
One bakelite wafer 5-prong socket

CENTRALAB

One 25,000 ohm potentiometer with Sw. type P-113
One 50,000 ohm potentiometer, type N-114
One 0.1 meg. potentiometer, type N-116
Two 0.5 meg. potentiometer, type N-118
One 2 meg. potentiometer, type N-122
One type 1450 switch—single-pole 6-position rotary type

THORDARSON

One power transformer, type T-14R32
One small 30 henry choke

SWITCHES

One toggle switch, single pole, single throw
One toggle switch, single pole, double throw

The "Curing" of a HAM

(Continued from page 394)

to be well in hand, until the discovery that I would have not the accustomed two ear-phones, but one!

In the adjoining room the examiner started his code machine.

The familiar "dits" and "dahs" began to emerge. My pencil pounced on the paper. Faculties, rushing headlong at the initial chirp, tripped over each other, and I missed the entire first word. The single earphone made me feel strangely divided. Half of me tense, eager activity; half of me impotent, complacent clay. *The chap in front had the earphone in his hand; shaking it violently next to his ear!*

In five minutes it was over and I had passed! Only the written test remained?X!??

"Draw a Diagram . . ."

The examiner handed me a question sheet—"Draw a diagram. . ." "Give three international regulations. . ." I could remember only two regulations. The license manual was in my back pocket. (*Mea maxima culpa!*) I reached for it.

"What kind of a Ham are you going to make?" questioned a lugubrious voice behind me. I later observed that it belonged to a rather frowzy individual who seemed to have a had case of vacation hair.

With that implication of future disaster, since I knew all the other answers, I withdrew my hand sans manual.

I Pass!

Two hours later and I was a licensed operator! Another application, more swearing, two weeks went by, and I was licensed operator of Radio Station W2EUN.

Time Marches On—

My receiving set was a good-looking job; it had the best of parts; my hands were crisp from the soldering iron but still the darn thing wouldn't work!

I remember that if all the knobs were turned completely to the right on the receiver, a deep-toned howl would emerge, gradually rising to a shriek. Fear that the house would gain an illicit reputation or a suspicion that the whole kaboodle might be haunted, made me decide to set the receiver aside permanently.

Need it be said that I and it were together again three days later? All it needed was a little adjusting. I told myself (by that time an old, old legend). As a matter of fact, that's all it did need. That and someone who knew when it was adjusted.

The Receiver Perks!

By a process of trial and tribulation, more painful than interesting, my first success arrived—a voice in German! Wouldn't anybody have thought it was Germany? And so I did. However, to my everlasting credit, I began to suspect something awful upon hearing so incongruous an inter-spersion as "Myrtle Avenue," followed soon after by a word that sounded like "furniture." This, in turn, was followed by disillusionment, the announcement: "V-A-R-D, Brooklyn, N. Y."

Still, the receiver is only half a Ham station. I had ears but no voice. And all this time my transmitter was preening on the floor, a magnificent mute!

The Transmitter Works—and How!

Strangely enough, the most severe tremors occurred after the transmitter was working. And how it was working! Working on every BCL set within a quarter-mile radius, instead of playing in its own backyard down on 160 meters. For a time, I say, my output of dots 'n' dashes (or dits 'n'

'dahs, as you prefer) punctuated Rudy Vallee's "Stein Song," and made sound effects on Winchell's program quite unnecessary.

Then, someone became interested in *First Cause*.

A Visit from the Radio Inspector

A visit from the local Radio Inspector occurred at the same time. He agreed with me perfectly; then went next door and did some more perfect agreeing. In brief, he admired my workmanship, sprinkled ashes on the rug, and advised wavetraps. He knew what he was talking about, though. Wavetraps eliminated the interference completely wherever used. In addition, I tried using a new antenna-coupling arrangement which blocked outside interference, except in the immediate neighborhood, where traps were used to total a hundred per cent cure. So it was, that, after six days of front-line action, I agreed with Shakespeare's bit of philosophy: "All's well that ends well."

At this time I considered it necessary to observe the type of signals transmitted by W2EUN, at a considerable distance away, where power-supply hum would not prevent an accurate report on tone and signal strength. Since I was unable to contact any other station, and none of my acquaintances owned short wave receivers, there was only one thing to do. Being a Ham, I did it.

Let me tell you about it.

An Exciting "Field Test"

About eight o'clock of a frosty morning, with Michaelmas well behind and 271 shopping days 'till Christmas, I packed the receiver in one suitcase, and in another, batteries, earphones, wire, pliers, and screwdriver. With each hand thus equipped, friend brother at home to handle the transmitter (he now had an operator's license), and my feet well on the ground, I set out to hear what I could hear.

When the car had passed through Flushing, I suddenly saw a very suitable site, no houses within two hundred feet. Yanking the bell cord, I started for the door. The car was filled, and consequently it could be said that my exit was well attended. Escorted, front and rear, by a suitcase, I "beg pardon'd" three-quarters of the way.

When the feast is all prepared, along comes one of these helpful birds.

"You from WMCA?" he started (this station is in the vicinity). I feigned deafness in both ears.

"Doin' some testin'?"

"I'm going to blast me a tree stump." I replied sharply.

Whatever the source of his motivation, I was glad to listen, in privacy, to the signals from my own station. They sounded good, too.

Up to this time my calls to other stations had always remained unanswered; perhaps, unanswerable. And no apparent reason! Then it happened.

My First "Contact"!

All night I had fished for a contact and like Peter saw no sanity in further attempts. Nearly all stations had signed off. But the goddess of fortune was beckoning, it seemed, and, being a greenhorn, I tried once more.

"Cq, cq, cq de W2EUN; cq, cq, cq de W2EUN."

With infinite care I turned the dial. Others joyfully pounding out code; a little static, and riding close by—"Oh! the dreams of ecstasy. Oh! Babylon and Troy!"—"W2EUN, W2EUN de W2COP."

CAST YOUR EYES
ON THESE
LAFAYETTE
BUYS!

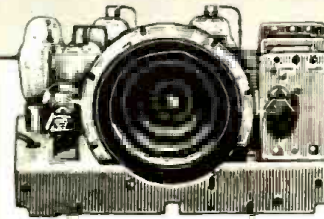

A couple of hours is all it takes to assemble this 4 tube TRF Broadcast Receiver. Uses 1-39, 1-36, 1-38 and 1-IV tubes. All parts furnished, including 5" magnetic speaker. Chassis is drilled and punched with all necessary holes. Specially matched coils and condensers. Operates on both AC and DC. Complete specifications.

YOUR \$495 COST

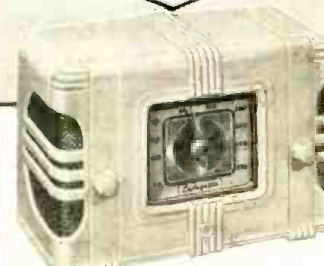

Performance, tone quality, beauty—Lafayette "nidget" Model C-39 has all three! And the price is remarkably low for so much extra-value. Features: 7 tube performance on 5 hi-efficiency tubes. Automatic Volume Control, new Wave Trap, 6" Dynamic Speaker. Smart plastic cabinet in Ivory, Walnut. See it in our catalog.

WALNUT \$995 ONLY

FREE

Whether you build your own or buy complete, this catalog has everything you need in radio. Mail coupon for your FREE copy today.

WHOLESALE RADIO SERVICE CO. INC.
NEW YORK, N. Y. • CHICAGO, ILL. • ATLANTA, GA.
100 SIXTH AVENUE 901 W. JACKSON BLVD. 285 PRITCHETT STREET
BOSTON, MASS. • BRONX, N. Y. • NEWARK, N. J. • JAMAICA, L. I.

WHOLESALE RADIO SERVICE CO., INC.
100 SIXTH AVENUE, NEW YORK, N. Y.

Rush FREE 1939 Catalog No. 73-4-LA

Name.....
Address.....
City..... State.....

PASTE COUPON ON PENNY POSTCARD

RADIO INSTRUCTION

Don't let **FAST CODE** SCARE YOU!

Learn to read it the quick, easy **CANDLER WAY!**

Do you have trouble reading fast code? You needn't have! Even if you have been trying for years to increase your speed without success, you'll find the Candler System helpful. With a few weeks practice the Candler way you will make more progress than you did with months of un-directed practice. Fast code is easy when you have the proper fundamentals, when you learn sound consciousness and mental coordination as Candler teaches it. You will find yourself reading code as easily as you read print without strain or conscious effort. Don't hesitate. Write today for your copy of the **FREE Book of Facts!**

FREE!
BOOK OF FACTS

Full of interesting data on codes! Read what champions tell you about the Candler System!



CANDLER SYSTEM CO.

Dept. S-11, ASHEVILLE, NO. CAROLINA, U.S.A.

YOUR FUTURE IN RADIO TELEVISION

• These growing industries need trained men for sales, service, operation. Your chance for employment and advancement depends on thorough training. National Schools offer you time-tested training. Complete, modern facilities and equipment in the largest trade school in the West.

Send for free booklet that shows how you can prepare for these opportunities.



NATIONAL SCHOOLS

4000 S. Figueroa Street, Los Angeles

NATIONAL SCHOOLS, Dept. RT11, Los Angeles
Please send free Radio and Television Booklet.

NAME _____ AGE _____
ADDRESS _____
CITY _____ STATE _____

LEARN CODE RIGHT

It's easy and practical to learn or improve your Radio or Morse code, any speed. Senior Model with 10 tapes and Book of Instructions \$20.25. Rented at \$3.00 first month, \$2.25 each additional month. 25c per month more with transformer and tube socket (oscillator unit). With key and head phones an additional 25c per month. \$10.00 deposit or satisfactory references required. Junior Model with 5 tapes and Book of Instructions \$12.00 (rented). Complete oscillator equipment less battery \$6.50. Send for details today.



INSTRUCTOGRAPH CO.

Dept. SW-11 912 Lakeside Place Chicago, Ill.
Representatives for Canada: Radio College of Canada 863 Bay Street Toronto

BE A RADIO SERVICE EXPERT

Modern receivers require men with modern training for service work. **LEARN AT HOME**. Our home instruction method and service equipment offer starts you earning money almost at once. Up to \$3 an hour easy in a short time. Write for free book. Radio Training Ass'n of America Dept. RT-811 Chicago 4525 Ravenswood Ave.

RADIO ENGINEERING

broadcasting, aviation and police radio, servicing, marine radio telegraphy and telephony, Morse telegraphy and railway accounting taught thoroughly. Engineering course of nine months' duration equivalent to three years of college radio work. All expenses low. Catalog free. School established 1874.

Dodge's Institute, Turner St., Valparaiso, Ind.

RADIO TEST-QUIZ?

(Continued from page 397)

has one, is always the connection for

- The screen grid.
- The control grid.
- The cathode.
- The plate.
- There is no general rule.
- An internal shield.

17. Shielding sets is quite a nuisance, but we have to do it to

- Keep the stages of the set from picking up interference.
- Keep the set's oscillator from radiating interference to neighbors' sets.
- Prevent interstage coupling.
- Make it harder for mugs like you to stick your clumsy mitts into the works.
- Keep the dust out.

18. The real reason we keep the leads short when building a short wave set is because

- We're too stingy to buy wire.
- To reduce stray inductance and capacity.
- To make the job look neat.
- To save space.
- A long piece of wire has higher resistance than a short piece.

19. Of the following commonly used abbreviations, one or more has no application to radio. Can you pick it or them out?

- | | |
|---------|--------|
| a. ICIV | d. SOS |
| b. QRN | e. MFD |
| c. TWA | f. TRF |

20. "Don't beat me, Henry," screamed the bride. "I now realize that you were right in saying a duolateral coil is just another name for a—"

- | | |
|--------------------|-------------------|
| a. Bank wound coil | d. Honeycomb coil |
| b. Solenoid coil | e. Spiderweb coil |
| c. Air-core coil | f. Pancake coil |

21. Just between us, the real purpose of a grid leak is to

- By-pass interference around the detector tube
- Prevent an R.F. stage from breaking into oscillation.
- Permit an accumulated charge to escape from a tube's grid.
- By-pass the R.F. component of the incoming wave past a tube's grid.

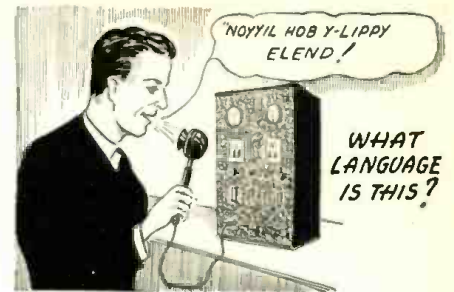

22. If you heard a man say, "Noyyil hob y-lippy elond" you'd be right if you said he was

- Telling what he thought of the European situation.
- Going nuts.
- Signing off for Station LYZZ, of Lahti, Finland.
- Testing a speech scrambler.

23. You would have the following stations correctly logged if you matched the call letters in the left column with the locations in the right-hand column. Go ahead and match them up. We dare you.

- | | | |
|----------|---------------------|---------------|
| a. HS8P1 | a. Skamleboak | a. 9.550 mc. |
| b. CR7BH | b. Prague | b. 14.920 mc. |
| c. OZG | c. Bangkok | c. 6.440 mc. |
| d. OLR3A | d. Sofia | d. 11.805 mc. |
| e. TGQA | e. Laurence Marques | e. 11.178 mc. |
| f. LZA | f. Quetzaltenango | f. 19.020 mc. |

24. If you were going to buy sockets for the following tubes, how many prongs would you have to take care of on each of the following?

- | | |
|--------|---------|
| a. 1B4 | d. 6A8 |
| b. 5W4 | e. 25Z5 |
| c. 6A6 | f. 6E5 |

25. When you use the term "radio range" in a conversation, you may mean almost anything, but which of the following is the correct definition.

- A radio beacon.
- An electric oven which receives its power by wireless.
- The distance a receiving set will cover.
- The distance a transmitter will radiate.
- The wave-band or bands covered by a receiver or transmitter.

(See page 425 for correct answers.)

The Television Torpedo

(Continued from page 390)

all times. This has been shown to be necessary in order to effectively steer it toward its target, because it is absolutely necessary, too, for the Control Engineer to be able to see the projectile at all times and see where it is going.

In our Television Torpedo, however, we mount an iconoscope or similar television tube. It is equipped with a large focusing lens which constitutes the "nose-piece" of the plane. Now we can transmit an image, through the iconoscope in the nose of the flying torpedo, to the screen in the cabin of the master plane several miles in the rear. The Control Engineer sees the image of the country-side exactly as though he

were riding in the torpedo! Result: The Engineer steers the Television Torpedo directly to its objective!

ROSS A. HULL

• THE radio industry in general and the radio amateur in particular will mourn the passing of Ross A. Hull, editor of QST, official publication of the American Radio Relay League. Mr. Hull may truly be said to have sacrificed his life for his work, for his death was caused by a 6000 volt shock, while he was engaged in an electrical experiment.

RADIO INSTRUCTION

READ SEND **CODE** Like an Expert

Learn Quickly at Home—Get Real Speed

It's easy, fascinating, to become a good op. with the NEW ALL ELECTRIC MASTER TELEPLEX CODE TEACHER to help you. Only instrument ever produced which records your sending in visible dots and dashes—then sends back to you at any speed you desire. Also sends practice work, recorded by an expert. That is why so many schools



teaching code prefer Master Teleplex, why thousands agree this method is surest and quickest. We furnish Complete Course, lend you Master FREE Teleplex, give you personal instruction with a MONEY-BACK GUARANTEE. **BOOK** Low cost. Send today for booklet \$11. no obligation.

TELEPLEX CO.

72-76 Cortlandt St. New York City

RALSTON RADIO CODE COURSE

At the A.R.R.L. Convention, "HAMS" RAVED over this easy, yet thorough method, for accurately learning code in half the usual time.

YOU NEED this set of recordings with excellent instruction book listing at \$8.00.

HEAR IT AT YOUR DEALER'S TODAY

or write
RALSTON RECORD COMPANY
5433 Willows Ave. Phila., Pa.

RADIO COURSES

RADIO OPERATING—BROADCASTING
For Gov't License Preparation

- RADIO SERVICING — a practical course
- RADIO AMATEUR CODE ● TELEVISION
- ELECTRONICS—1 yr. day course 2 yrs. eve. Day and Evening Classes. Booklet Upon Request.

New York Y.M.C.A. Schools
6 W. 84th Street New York City
Trade and Technical School
Licensed by the State of New York

LEARN RADIO TELEVISION

500 LICENSED graduates placed in past 7 years in shipping, broadcasting, aviation, police, etc.; we also teach radio servicing and repairing; new beginners' class Sept. 12th, Nov. 7th; 52-page catalog free; oldest, largest and best equipped.

MASS. RADIO SCHOOL

18 BOYLSTON ST., BOSTON Est. 1899

RADIO ENGINEERING

RCA Institutes offer an intensive course of high standard embracing all phases of Radio and Television. Practical training with modern equipment at New York and Chicago schools. Also specialized courses and Home Study Courses under "No obligation" plan. Catalog Dept. SW-38.

RCA INSTITUTES, Inc.

A Radio Corporation of America Service
75 Varick St., New York. 1154 Merchandise Mart, Chicago

A NEW SERVICE FOR OUR READERS!

Be sure to see the new
Free Catalogs and Information
Department on Page 447

New Television Receiver

(Continued from page 409)

The completed set revealed a clear image on a five-inch cathode-ray tube.

Television, in the opinion of Max W. Weintraub, president of the Garod firm, during its pioneer stages of public introduction, can bring considerable extra fun to the home experimenter who has the privilege of building his own set.

Immediate release of the kits was decided upon because it is believed that public interest, together with the comparative perfection of television transmission, make a moderately priced television outfit desirable.

The set uses sixteen tubes in addition to the 5-inch cathode-ray tube, upon the end of which the picture is reproduced. The use of electrostatic instead of electromagnetic deflection in the cathode-ray tube greatly simplifies construction.

This article has been prepared from data supplied by courtesy of the Garod Radio Corporation.

NEXT ISSUE:

Local HAM Gossip

Be sure to send News of your Local Club's Activities—Photos Welcome—See page 343, October issue.

New Medium High Power Transmitter

(Continued from page 409)

phonograph pickup. By the use of an external line to grid transformer, a telephone line may be fed into Channel No. 2. Plate control buttons with associated pilot lights are incorporated in this unit for control of the transmitter. An undistorted output of 10 watts with an audio frequency response flat from 80 to 10,000 cycles within plus or minus 3 db. is obtained. For cw. operation the secondary of the class B output transformer is short-circuited and the plate voltage removed from the modulator stage. The speech amplifier may also be turned off by means of a panel controlled switch.

The next lower deck contains the C bias power supply furnishing fixed bias voltages to the R.F. stages. A pair of RK52's in class B, operating with a plate voltage of 1250 are capable of modulating the final amplifier to 100%. These tubes are of the zero bias type and do not require any C bias voltage. The "PHONE-CW." switch, voltage dividers and main line fuses, as well as the filament voltmeter and modulator plate current meter, complete the equipment mounted on this unit.

A 1250 volt supply with 866 rectifiers, provides power for intermediate and final amplifiers and modulator stage. A two section choke input filter affords low hum level and excellent power regulation. A separate winding on the main power transformer furnishes 550 volts to the exciter unit. This supply also employs a two section choke input filter. For tuning purposes a resistor is connected in series with the primary winding of the power transformer. A heavy duty relay controls the application of plate voltages to the transmitter. Remote control is accomplished by means of the control box furnished with the transmitter.

This article has been prepared from data supplied by courtesy of Transmitter Equipment Mfg. Co.

Please say you saw it in RADIO & TELEVISION

RADIO INSTRUCTION

SEE WHAT \$4 WILL BUY!

RADIO PHYSICS COURSE

ALFRED A. CHIRARDI

Here's what you learn:

Sound, Speech and Music — Electrons — Electric Current — Electric Units and Circuits — Resistance — Ohm's Law — Batteries — Magnetism — Electromagnetism — Transformers — Inductance — Condensers — Alternating Current Circuits — Filters — Electrical Measuring Instruments — Radio Waves — Radiations — Broadcast Stations — Receiving Equipment — Vacuum Tubes — Radio and Audio Frequency Amplification — Superheterodynes — Loud Speakers — Battery Operated Receivers — Power Supply Units — Electric Receivers — Automobile and Aircraft Receivers — Phon-

36 RADIO BOOKS IN ONE

Think of it! A complete radio education for only \$4 in this 1 big training book you will quickly learn Radio, Electricity, Sound, Television etc. In 36 sections, each the equivalent of an ordinary book, you will pick up step by step all essential knowledge required for a thorough grounding in RADIO.

SO EASY IT'S AMAZING!

You will be surprised and delighted at your rapid progress once you start reading Chirardi. No previous training is necessary. Chirardi has an uncanny knack for making everything crystal-clear. Intricate problems seem ridiculously simple the way he explains them. That's why this book is used by more radio schools and students than any other radio text.

10-DAY TRIAL

Fit yourself at home for a good-paying radio job this quick, inexpensive, most popular way. Send the coupon for your copy at once. You risk nothing; your money is automatically refunded if you return the book within 10 days. The whole fascinating field of Radio lies ahead of you—get into it NOW!

TEAR OUT—MAIL NOW!

Group Pickups — J. A. Systems — Short - Wave Receivers — Photoelectric Cells — Television — Antennas and Grounds — Testing and Servicing Receivers — Sound Motion Pictures — Appendices—866 (review Questions for Self-Tests) AND DOZENS OF OTHER SUBJECTS!

972 pp. 500 illus. \$4

RADIO & TECHNICAL PUBLISHING CO.,
45 Astor Place, New York Dept. SW-118

Here is \$4 (\$4.50 foreign) for my copy of RADIO PHYSICS COURSE. Ship postpaid at once with 10-day money-back guarantee.

NAME

ADDRESS

CITY

STATE

Send free descriptive literature.

LEARN RADIO THE Easy WAY

New! **Speedy!**

Ghirardi's WORLD-Indicator **Radio TIME Gadget**

It's marvelous! This handy little gadget shows you exactly when and where to tune in any radio program, any time, anywhere! No more figuring—Ghirardi's gadget does all that work automatically!

Shows in a Flash the correct Standard, Daylight and Greenwich Mean Time for programs of any short-wave radio station in the world!

Risk nothing! Your money back if not satisfied after 10 days trial. Just write your name and address on this ad; mail at once with 50c (10c foreign). We ship postpaid anywhere!

50c POSTPAID

A Turn of the Disc and there's the Time!

RADIO & TECHNICAL PUBL. CO.,
45 Astor Place, Dept. R.T-118,
New York, N. Y.

A Modern Desk Lamp FREE with your subscription. See Page 436.

AMERICA'S MOST POPULAR RADIO BOOKS

We herewith present a selected collection of recent important radio books. We have selected these volumes because they represent the foremost radio books of their kind in print today. We publish no catalog. Order direct from this page. Prompt shipments will be made to you. Remit by money order or certified check. Register all letters containing cash.

RADIO ENGINEERING HAND BOOK 850 pages, latest.	\$4.90
PRACTICAL TELEVISION 223 pages, 127 illus.	\$3.69
ELEMENTS OF RADIO COMMUNICATION , 286 pages, 241 illus.	\$2.98
RADIO PHYSICS COURSE , 992 pages, 510 illus.	\$4.00
THE RADIO AMATEUR'S HANDBOOK , 448 pages, 126 illus.	\$1.97
MODERN RADIO ESSENTIALS , over 200 pages, and over 100 illus.	\$1.95
FOUNDATIONS OF RADIO , 246 pages, 145 illus.	\$2.47
PHOTOCELLS AND THEIR APPLICATION , 332 pages, 28.88 illus.	\$2.88
ELECTRONICS , 134 pages, 45 illus.	\$1.95
SHORT WAVE RADIO HAND BOOK , 128 pages, 150 illus.	\$1.00
PRINCIPLES OF RADIO , 478 pages, 306 illus.	\$3.46
EXPERIMENTAL RADIO , 256 pages, 168 illus. Prepaid	\$2.69
MODERN RADIO SERVICING , 1300 pages, over 700 illus.	\$4.00
FIELD SERVICE DATA AND ANSWER BOOK , 436 pages	\$2.50
Both Books	\$6.00
DRAKE'S CYCLOPEDIA OF RADIO AND ELECTRONICS , 1050 pages, 1178 illus.	\$4.88

FUNDAMENTALS OF RADIO , 426 pages, Illustrated. Prepaid	\$3.46
HOW TO PASS RADIO LICENSE EXAMINATIONS , 1938 Edition, 201 pages, Illustrated	\$2.00
RADIO CONSTRUCTION AND REPAIRING , 444 pages, Illustrated	\$2.50
THEORY OF VACUUM TUBE CIRCUITS , 226 pages, 226 illus.	\$3.00
PRINCIPLES OF RADIO COMMUNICATION , 988 pages, Profusely illus.	\$7.35
RADIO ENGINEERING , 813 pages, 475 illus.	\$5.50
EXPERIMENTAL RADIO ENGINEERING , 346 pages, 250 illus.	\$3.46
RADIO OPERATING QUESTIONS AND ANSWERS , 427 pages, 106 illus.	\$2.50
OFFICIAL RADIO SERVICE HANDBOOK , over 1,000 pages, over 1,000 illus. Prepaid	\$3.92
OFFICIAL SHORT-WAVE RADIO MANUAL , 240 pages, many illustrations, Vol. 1 (1934) Prepaid	\$2.00
Vol. 2 (1935) Prepaid	\$2.50
OFFICIAL RADIO SERVICE MANUAL , Volume 4, 2,000 pages, over 400 pages, Prepaid	\$3.43
OFFICIAL RADIO SERVICE MANUAL , Volume 5, over 3,000 pages, over 1,000 pages, Prepaid	\$6.86
OFFICIAL RADIO SERVICE MANUAL , Volume 6, over 1,200 pages, over 2,500 illus., Prepaid	\$6.86

15 HANDY—POCKET-SIZE RADIO BOOKS

Here are 15 up-to-date books on radio and air conditioning. Modern in every sense. ALL BOOKS UNIFORM—they contain 64 pages; 50 to 120 illustrations. All books written by well-known authors. Order by Number.

2. MODERN VACUUM TUBES
3. THE SUPERHETERODYNE BOOK
5. HOW TO BECOME A SERVICE MAN
6. BRINGING ELECTRIC SETS UP TO DATE
8. RADIO QUESTIONS AND ANSWERS
9. AUTOMOBILE RADIO AND SERVICING
10. HOME RECORDING AND ALL ABOUT IT
12. PUBLIC ADDRESS INSTALLATION AND SERVICE
13. ABC OF AIR CONDITIONING
14. POCKET RADIO GUIDE
15. ABC OF REFRIGERATION
16. PRACTICAL RADIO CIRCUITS
17. SERVICING WITH SET ANALYZERS
18. POINT-TO-POINT RESISTANCE ANALYSIS
19. PRACTICAL RADIO KINKS AND SHORT CUTS

PRICE PREPAID EACH BOOK **50c**

HOW TO ORDER

No C.O.D. orders. Our prices are net, as shown. Some of the books sent prepaid (in U.S. only). Those that are not thus listed are shipped collect if sufficient postage is not sent. Add 7% of price for postage.

RADIO PUBLICATIONS, 97 HUDSON ST., NEW YORK, N. Y.

Westinghouse Power Generator

Manufactured for U. S. Signal Corps
200 Watt. 110 V. AC

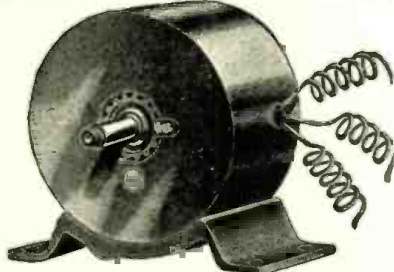

A. C. ELECTRICAL POWER

from a Windmill, from available Waterpower, from Your Automobile, from your Motorcycle, from your Bicycle, Foot-pedal or Handcrank (for transportable Radio Transmitters, Strong Floodlights, Advertising Signs); do you want to operate AC Radio sets from 32 V. DC farm light systems; operate two generators in series to get 200 V. AC; obtain two phase and three phase AC, etc. etc.

There Are Over 25 Applications
Some of which are:

A.C. Dynamo lighting from eight to ten 20 Watt 110 Volt lamps. Short Wave Transmitter supplying 110 Volts AC for operating "Ham" transmitter. Operating 110 V. AC 60 Cycle Radio Receiver in DC districts. Motor Generator. Public Address Systems. Electric Sirens on motor boats, yachts, etc. Camp Lighting. Short Wave artificial "fever" apparatus. Television. Pelton Waterwheel for lighting or other purposes. Airplane: for lighting strong searchlights or electric signs. Laboratory work, etc. etc. 1/4 to 1/2 H.P. needed to run generator.

BLUE-PRINT 22 x 28 in. and Four-Page 8 1/2 x 12 in. INSTRUCTION SHEETS FREE with Generator.

Generator, as described, including four replacement carbon brushes. Blue-print and Instructions **\$7.90**

Send \$2.00 deposit, balance C.O.D. Shipping weight 18 lbs. (Replacement carbon brushes bought separate \$1.50 per set of four. Set of instructions bought separate \$1.00.) MONEY-BACK GUARANTEE

WELLWORTH TRADING COMPANY

560 West Washington Blvd., Dept. RT-1138, Chicago, Ill.

World S-W Stations

(Continued from page 412)

Mc.	Call	Station
6.500	HIL	CIUDAD TRUJILLO, D. R., 46.13 m. Addr. Apartado 623. 12.10-1.40 pm., 5.40-7.40 pm.
6.480	H1IL	SANTIAGO DE LOS CABALLEROS, D. R., 46.28 m., Addr. Box 356. 9.40-11.40 am., 7.40-9.40 pm.
6.470	YNLAT	GRANADA, NICARAGUA, 46.36 m., Addr. Leonidas Tenorio, "La Voz del Mombacho." Irregular.
6.465	YV3RD	BARQUISIMETO, VENEZUELA, 46.37 m. Radio Barquisimeto, irregular.
6.450	H14V	SAN FRANCISCO DE MACORIS, D. R., 46.48 m., 11.40 am.-1.40 pm., 5.10-9.40 pm.
6.440	TGQA	QUEZALTENANGO, GUATEMALA, 46.56 m. Daily 6.10-10.10 pm., Sun. 1-3 pm.
6.420	H1IS	SANTIAGO, D. R., 46.73 m. 11.40 am.-1.40 pm., 5.40-7.40, 9.40-11.40 pm.
6.416	YV6RC	BOLIVAR, VENEZUELA, 46.73 m. Radio Bolivar.
6.410	TIPG	SAN JOSE, COSTA RICA, 46.8 m., Addr. Apartado 225, "La Voz de la Victor." 12 n.-2 pm., 6-11.30 pm.
6.400	YV5RH	CARACAS, VENEZUELA, 46.88 m. 7-11 pm.
6.388	H18J	LAS VEGAS, D. R., 46.92 m., Irreg.
6.384	VP2LO	STE. KITTS, B.W.I. 46.96 m. ICA Service Labs, Box 88, Daily 4-4.45 pm., Sun. 10-10.45 am. and irreg. at other times.
6.380	YV5RF	CARACAS, VENEZUELA, 46.92 m., Addr. Box 983. 6-10.30 pm.
6.370	T18WS	PUNTARENAS, COSTA RICA, 47.07 m., Addr. "Ecos Del Pacifico", P. O. Box 75. 6 pm.-12 m.
6.365	YV1RH	MARACAIBO, VENEZUELA, 47.18 m., Addr. "Ondas Del Lago." Apartado de Correos 261. 6-7.30 pm.
6.360	HRPI	SAN PEDRO SULA, HONDURAS, 47.19 m. 7.30-9.30 pm.

Mc.	Call	Station
6.340	H1IX	CIUDAD TRUJILLO, D. R., 47.32 m. Sun. 7.40-10.40 am., daily 12.10-1.10 pm., Tues. and Fri. 8.10-10.10 pm.
6.335	OAXIA	ICA, PERU, 47.33 m., Addr. La Voz de Chiclayo, Casilla No. 9. 8-11 pm.
6.324	COCW	HAYANA, CUBA, 47.4 m., Addr. La Voz del Radio Philco, P. O. Box 130. 6.55 am.-12 m. Sun. 9.55 am.-10 pm.
6.310	H1Z	CIUDAD TRUJILLO, D. R., 47.52 m. Daily except Sat. and Sun. 11.10 am.-2.25 pm., 5.10-8.40 pm. Sat. 5.10-11.10 pm. Sun. 11.40 am.-1.40 pm.
6.300	YV4RD	MARACAY, VENEZUELA, 47.62 m. 6.30-9.30 pm. exc. Sun.
6.295	OAX4G	LIMA, PERU, 47.63 m., Addr. Apartado 1242. Daily 7-10.30 pm.
6.280	H1G	TRUJILLO CITY, D. R., 47.77 m. 7.10-9.40 am., 11.40 am.-2.10 pm., 3.40-9.40 pm.
6.270	YV5RP	CARACAS, VENEZUELA, 47.79 m., Addr. "La Voz de la Philco." Daily to 10.30 pm.
6.255	YV5RJ	CARACAS, VENEZUELA, 47.18 m.
6.243	H1N	CIUDAD TRUJILLO, D. R., 48 m., Addr. "La Voz del Partido Dominicano." 12 n.-2 pm., 6-10 pm.
6.240	ZGE	KUALA LUMPUR, FED. MALAY ST., 48.1 m. Addr. Malayan Amateur Radio Society. Sun. Tues. and Fri. 6.40-8.40 am.
6.235	HRD	LA CEIBA, HONDURAS, 48.12 m., Addr. "La Voz de Atlantida." 8-11 pm.; Sat. 8 pm.-1 am.; Sun. 4-6 pm.
6.225	YV1RG	VALERA, VENEZUELA, 48.15 m. 6-9.30 pm.
6.210	—	SAIGON, INDO-CHINA, 48.28 m., Addr. Radio Boy-Landry, 17 Place A. Foray. 4.30 or 5.30-9.15 am.
6.205	YV5RI	CORO, VENEZUELA, 48.32 m., Addr. Roger Leyba, care A. Urbina y Cia. Irregular.
6.200	H18Q	CIUDAD TRUJILLO, D. R., 48.36 m. Irregular.
6.190	TG2	GUATEMALA CITY, GUAT., 48.4 m., Addr. Dir. Genl. of Electr. Commu. Relays TG1 Mon.-Fri. 6-11 pm., Sat. 6 pm.-1 am. Sun. 7-11 am., 3-8 pm.
6.185	H1IA	SANTIAGO, D. R., 48.5 m., Addr. P. O. Box 423. 7 am.-5 pm.
6.156	YV5RD	CARACAS, VENEZUELA, 48.71 m. 11 am.-2 pm., 4-10.40 pm.
6.153	H15N	MOCA CITY, D. R., 48.75 m. 6.40-9.10 pm.

49 Met. Broadcast Band

6.150	CJRO	WINNIPEG, MAN., CANADA, 48.78 m., Addr. (See 11.720 mc.) Daily 6 pm.-12 m., Sun. 5-10 pm.
6.150	ZP14	VILLARRICA, PARAGUAY, 48.75 m. 5-6 pm.
6.147	ZRD	DURBAN, SOUTH AFRICA, 48.8 m., Addr. (See ZRK, 9.606 mc.) Daily exc. Sat. 11.45 pm.-12.50 am.; Daily exc. Sun. 3.30-7.30 am., 9 am.-3.45 pm.; Sun. 5.30-7, 9-11.30 am., 12 n.-3.20 pm. Also 4-5 am., 3rd Sun. of month.
6.147	ZEB	RULAWAYO, RHODESIA, S. AFRICA, 48.8 m. Mon., Wed., and Fri. 1.15-3.15 pm.; Tues. 11 am.-12 n.; Thurs. 10 am.-12 n. Sun. 3.30-5 am.
6.145	HJ4ABG	MEDULLIN, COL., 48.79 m. 11 am.-12 n., 6-10.30 pm.
6.140	W8XK	PITTSBURGH, PA., 48.83 m., Addr. Westinghouse Electric & Mfg. Co. Relays KDKA 11 pm.-12 m.
6.137	CR7AA	LAURENCO MARQUES, PORT. E. AFRICA, 48.87 m. Daily 12.05-1, 4.30-6.30, 9.30-11 am., 12.05-4 pm., Sun. 5-7 am., 10 am.-2 pm.
6.133	XEXA	MEXICO CITY, MEX., 48.93 m., Addr. Dept. of Education. Daily 8-11 am., 2.30-4 pm., 7.30 pm.-12.45 am. Sun. 1.30 pm.-12.45 am.
6.130	VP3BG	GEORGETOWN, BRIT. GUIANA, 48.94 m. From 5 pm. on.
6.130	TIEM	SAN JOSE, COSTA RICA, 48.94 m. "El Mundo", Apartado 1049. 11 am.-11 pm., Sun. 10 am.-6 pm.
6.130	VE9HX	HALIFAX, N. S., CAN., 48.94 m., Addr. P. O. Box 998. Mon.-Fri. 7 am.-11.15 pm., Sat. 11 am.-11 pm., Sun. 12 n.-11.15 pm. Relays CHNS.

(Continued on page 438)

The ARMY Amateur Network

(Continued from page 392)

Organization

The territory of the United States is divided into nine Corps Areas by the Army for the purpose of military administration and operation. The I Corps Area comprises the New England States with headquarters at Boston, Mass. The II Corps Area consists of the States of New York, New Jersey and Delaware and the Territory of Puerto Rico. Its headquarters are at Governors Island, New York Harbor. The headquarters of the remaining Corps Areas are, in numerical order, at the following places: Baltimore, Md.; Atlanta, Ga.; Columbus, Ohio; Chicago, Ill.; Omaha, Neb.; San Antonio, Texas; and San Francisco, Calif. In a like manner, the administration and operation of the Army Amateur Radio System is divided among the nine Corps Areas.

Radio Nets

The basic organization of the radio communicating system in the Army is the "Net," which consists of two or more radio stations located at the headquarters or office of the units which they serve. All stations in a net usually operate on the same single frequency. A Regimental Net, for example, would comprise the station at Regimental Headquarters, known as the Net Control Station, or NCS, and the stations at the headquarters of each of the three battalions comprising the regiment as the other members or secondary stations. The station of the highest or ranking unit in a net is designated as the NCS (Net Control Station) and directs the operations of the net. Following out this principle, the ARMY AMATEUR RADIO SYSTEM is built up of a series of nets, starting at the top with the Army NCS W3CXL-WLM at Washington, D. C.—which is under the direction of the Liaison Officer of the A.A.R.S.—and branching out through Corps Areas and State Nets; in order to include every affiliated Army amateur radio station in the system.

The inter-linking of this communicating system can be best illustrated by the following detailed net organization of the A.A.R.S. in the II Corps Area:

(1) *II Corps Area Net:* W2SC-WLN is the NCS and is located at Governors Island, N. Y., the headquarters of the Second Corps Area. Alternate Net Control Stations, or NC2, NC3, etc., are W2BCX-WLNF at Elizabeth, N. J.; W2PF-WLNA (also the Radio Aide) at Brooklyn, N. Y.; W2HQL-WLNR at Fort Monmouth, Oceanport, N. J., and W2BME-WLNO at Southampton, N. Y. The other or secondary stations are the respective State Net Control Stations of the five State Nets into which the Corps Area has been divided for the purpose of net operations in the A.A.R.S. These stations are: W2DBQ-WLNB, Southern N. Y. State NCS at Brooklyn, N. Y.; W2GZF-WLNC, Eastern N. Y. State NCS at Monroe, N. Y.; W8CSE-WLNM, Western N. Y. State NCS at Tully, N. Y.; W3ZI-WLNE, New Jersey State NCS at Trenton, N. J., and W3GZH-WLNI, Delaware State NCS at Wilmington, Del.

(2) *State Nets:* The States of New Jersey and Delaware are each designated as State Nets, but New York State is divided geographically into three separate State Nets in order to handle satisfactorily the many net members in this State.

All Army amateur stations, except the Corps Area NCS at Governors Island, which is operated by Signal Corps personnel, are owned and operated by their

respective amateur operators. Each net is assigned a specific single frequency for all operations and, as the frequency assignments are coordinated by the Liaison Officer of the A.A.R.S. in Washington, interference between different nets is held to a minimum by separating each net frequency assignment by 2.5 kcs. or greater. The following is a list of some of the frequencies in the amateur 3500-4000 kc. band allocated to Army amateur stations in the II Corps Area:

II Corps Area Net	3510 kcs.
New Jersey State Net	3535 kcs.
Delaware State Net	3565 kcs.
Southern N. Y. State Net	3710 kcs.
Eastern N. Y. State Net	3742.5 kcs.
Western N. Y. State Net	3520 kcs.
Southern N. Y. Radiophone Net	3915 kcs. (phone)

Net Operation

In military work, there is a "chain of command" over which all orders pass from the highest commanding officer or office to the lowest subordinate. It is most essential that this "chain" be maintained and that all correspondence and messages follow the established routine in order that the Army—or for that matter, any large business or public service corporation—may function properly and efficiently. Therefore, subordinate stations in a net only communicate, during the regular drill schedules, with their net control station and not with stations in different nets.

To assemble over 1,300 stations on the air on a particular night of the week, or at any certain time is a colossal task, even assuming that no interference is caused by other amateur radio stations. However, from the experience gained from several years of A.A.R.S. operations, Monday night has been selected as the regular drill night when all Army amateur members are expected to tune to the Army Amateur Net Control Station WLM, Washington, D. C., and copy the "ZCVA" (general broadcast) message that is transmitted on the special Army amateur frequencies of 3497.5 and 6990 kcs. simultaneously, at 7:00 P.M. and 10:00 P.M., E.S.T. The "ZCVA" is a sort of weekly bulletin from the office of the Chief Signal Officer that announces the various tests, contests or special drills that are constantly being initiated for the training of the members.

Cooperation with Red Cross

In the event of an emergency, the Army amateur would immediately contact his local Red Cross representative, offer his services and await further orders from the latter or other authorities.

During emergencies, all members of the A.A.R.S. are expected to man their stations, report into their respective nets and be prepared to assist in the speedy and efficient handling of important messages.

The Army Amateur

For all his voluntary work, as keeping regular Monday night drills and other schedules, enciphering and deciphering messages, learning Army radio procedure, standing by or assisting in emergency operations, the Army amateur radio operator does not receive one cent, either directly or indirectly, from the government. Instead, the amateur must construct and maintain his radio station at his own expense—no equipment can be furnished by the War Department under existing regulations. Nevertheless, he does all this not for any personal glory, but rather to prepare himself to best serve his country in time of an emergency.

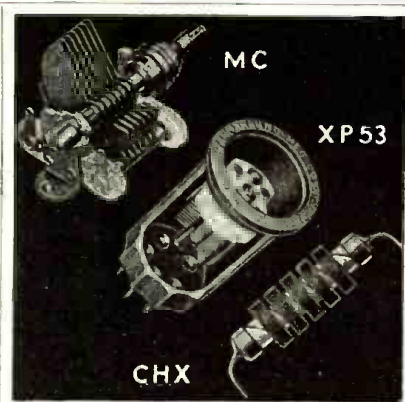

Three Favorites

Hammarlund's products are backed by twenty-seven years of experience in designing and manufacturing short wave components. The "three favorites" illustrated above are the essentials for a good short wave band-spread receiver. "MC" with its special bearings and contacts is noiseless in operation. "XP-53" coil form accommodates the band-setting condenser and provides permanent calibration. "CH-X" is the acme in R.F. chokes for high frequencies. Send for "39" catalog containing complete details.

HAMMARLUND MFG. CO., INC.
424 W. 33rd St., N.Y.C. RT-11
() Please send new 1939 Catalog.

Name
Address
City State



Canadian Office: 41 West Ave. No.,
Hamilton, ONT.

HAMMARLUND

MULTI-UNIT MICROPHONE



ASTATIC

New series!
Public address
and night club
leader. Cannot
be acoustically
overloaded. Made
in two models.

ASTATIC MICROPHONE
LABORATORY, INC.

Dept. J-4,
Youngstown, Ohio
Licensed Under Brush
Development Co. Patents

Write
for
Literature

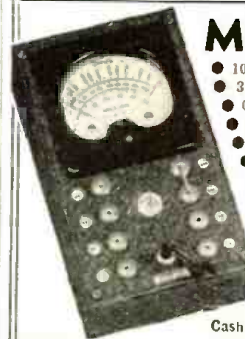

MODEL S

- 1000 ohms per volt
- 3 in D'Arsonval
- 0-5-50-500-1000 volts D.C.
- 0-1000 ohms
- 0-300,000 ohms
- Zero adjuster same setting for both scales
- 0-1 M. A.
- 3 1/4 x 6 x 2 in.
- Durable Metal Case with Rubber Feet
- Complete Instructions

Dealers' Net \$7.95
Cash Price Only

MILLION RADIO & TELEVISION LABORATORIES
677 W. Ohio Street, Chicago, Ill.

CHASSIS — CABINETS PANELS & CANS

STANDARD SIZES ON HAND
SPECIAL SIZES MADE TO ORDER
KORROL RADIO PRODUCTS CO.

350 Greenwich St. Dept. S-11 New York City

STOP, LOOK & BUY!

Rockbottom Prices On Army and Navy and Surplus Merchandise

When prices are low we buy! They're low now—LOWER THAN THEY EVER WILL BE—hence this sale. Most of the merchandise is new—never used; some of it reconditioned. 100% satisfaction on each transaction or your money refunded.

ORDER FROM THIS PAGE. Use the convenient coupon below. Be sure to include sufficient extra remittance for parcel post charges, else the order will be shipped express, charges collect. Any excess will be refunded. C.O.D. shipments require a 20% deposit. If full remittance accompanies order deduct 2% discount. Send money order—certified check—new U. S. stamps. No C.O.D. to foreign countries.

ORDER TODAY QUANTITIES LIMITED QUICK SHIPMENTS ASSURED

EDISON 1/50TH H.P. UNIVERSAL MOTOR

Made by Edison Electric Co. for Dictaphone machines. Can be used on 110 volt D.C. or A.C. lines; any frequency on A.C. Double shaft. 5/16th in. diam. Any speed obtainable with suitable rheostat. Size 9" x 4" high. x 5 3/4" wide overall. Shp. Wt. 8 1/2 lbs.

ITEM NO. 10
Your Price **\$2.25**



VARIABLE SPEED UNIVERSAL MOTOR

FOR 110 VOLTS, A.C. OR D.C.
Made for Dictaphone machines by American Gramophone Co. Used, but in excellent condition. Special lever control permits variable speeds up to 3000 r.p.m. 1/4" shaft extends from both sides of motor. Measures 7 1/2" x 3 1/4" diam. overall. Shp. Wt. 6 3/4 lbs.

ITEM NO. 11
Your Price **\$2.55**



SPERRY GYROSCOPE LIQUID COMPASS

Made for U.S. Signal Corps; sensitive and accurate. Quick readings easily made from top; accurate readings of graduations through focusing magnifying lens on side of instrument. Complete with level sights and russet leather carrying case. Excellent for boats, boy scouts, campers, hikers, etc. A few turns of wire around its case makes it usable as a Galvanometer. Shp. Wt. 3 lbs.

ITEM NO. 12
Your Price **\$1.85**



WESTERN ELECTRIC BREAST MIKE

A lightweight aircraft-type carbon microphone, with breast plate mounting. Can be adapted for home broadcasting or private communication systems. With cord and plug. Shp. Wt. 4 lbs. (Illustrated at right.)

ITEM NO. 14
Your Price **\$2.45**

Magnavox Anti-Noise Microphone, also good for home broadcasting etc. With cord and plug. Shp. Wt. 4 lbs.

ITEM NO. 15
Your Price **\$1.80**



PORTABLE TELEGRAPH AND BUZZER FIELD SETS

Made for military use by Western Electric. A wonderful buy if only for the parts it contains. Never before used. Good for code practicing, signaling, communications, etc. Contains 2-tone, high-frequency buzzer with platinum contacts, telegraph key, telephone switches, carbones, condensers, transformer, chokes, etc. A \$50 value easily. Complete in wooden case with 61 pages and instructions. Shp. Wt. 12 lbs.

ITEM NO. 16
Your Price **\$5.45**

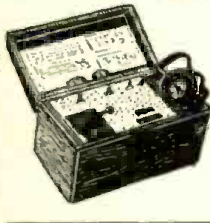

NAVY PORTABLE SEARCHLIGHT

1 1/2 MILE RANGE
Cast aluminum and bronze housing. Mangan type parabolic glass reflector 5" diam. Trigger switch and handle for operating, tilting and focussing lamp. Made by General Electric and National X-Ray Co. for U.S. Navy. Measures 4" deep x 5 1/2" diam. overall. Focal length 1 1/2". Approximately 100 candle power. Has threaded nipple for 3/8" pipe support. Complete with wooden carrying case. Excellent for campers, trailers, barns and outdoor and indoor displays. Supplied with either 6 or 12 volt lamp. Shp. Wt. 14 lbs. (Net 4 lbs.)

ITEM NO. 17
Your Price **\$6.65**



PRISMATIC RIFLE SIGHT AND OBSERVERS' SCOPE

Made by Warner & Swasey. Consists of achromatic ocular and objective lens (6 power), calibrated reticule with cross hairs, 2 highly polished prisms set in solid bronze frame with soft rubber eye cup. Micrometer adjustments for yardage and windage. Range 50 to 5000 yds. Used on Krak, Enfield, Savage, Springfield, etc. With mount and leather case. Shp. Wt. 4 lbs. Regular price \$38.00.

ITEM NO. 18
Your Price **\$8.95**



AIRCRAFT GENERATOR PROPELLER

"Deslauriers" automatic controllable pitch. Operating speed 4,500 r.p.m. Blade 11 1/2" x 2", sweep 23". All aluminum and bronze housing. Complete with streamlined housing (shown dotted). Fits 9/16" shaft. Net weight 3 1/2 lbs. Shp. Wt. 7 1/2 lbs. Original cost \$200.

ITEM NO. 19
Your Price **\$5.25**



TELEGRAPHIC TAPE RECORDER

A wonderful buy! Apparatus makes a written record of code and similar messages on paper tape. An ideal machine for learning code or teaching code to groups. Radio men can easily adapt it to short-wave receivers for taking permanent records of code messages. Double pen permits simultaneous recording of two messages. Pens are operated by battery and key while tape feeder is spring driven (hand wound). Case made of solid brass on heavy iron base. Completely reconditioned. (Less tape; easily obtained anywhere.) Original cost \$85.00. Shp. Wt. 20 lbs.

ITEM NO. 20
Your Price **\$19.95**

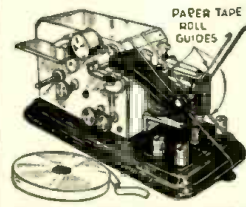

NAVY FLOODLIGHT

Made to U.S. Navy rigid specification these sturdily constructed floodlights are now available at less than half of their original price of \$70.00. Brand new merchandise, never before used. Pittsburgh floodlight type FLC-500, 18" Durax aluminum reflector. Floodlight has double adjustments and is weatherproof. Takes 300 to 500 Watt Mazda base lamp. Measures 18" x 18" x 24" overall. Shp. Wt. 55 lbs.

ITEM NO. 21
Your Price **\$29.70**



ANTI-CAPACITY SWITCHES

Made by Western Electric. Double throw switch with 12 terminals—equivalent to two double-pole, double-throw switches. All contacts are of platinum plate. Original price \$3.50 each. Shp. Wt. 1 lb.

ITEM NO. 23
Your Price **\$1.55**



ARMY AIRCRAFT KEY

Type J-E Army aircraft solenoid brass transmitting key with large heavy duty Tungsten contacts. Well balanced. Non-slip on the fist. Shp. Wt. 2 lbs.

ITEM NO. 22
Your Price **\$1.90**



WE HAVE NO CATALOG. ORDER FROM THIS PAGE.
HUDSON SPECIALTIES - 40-T West B'way - N.Y.C.

IT'S EASY TO ORDER—CLIP COUPON—MAIL NOW

HUDSON SPECIALTIES CO., 40-T, West Broadway, N. Y. C. 1138

I have circled below the numbers of the items I'm ordering. My full remittance of \$..... (include shipping charges) is enclosed.
OR my deposit of \$..... is enclosed, (20% required), ship order C.O.D. for balance. (New U.S. stamps check or money order accepted.)

Circle Item No. wanted: 10 11 12 14 15 16 17 18 19 20 21 22 23

Name Address

City State

Send remittance by check, stamps or money order; register letter if you send cash or stamps.

NEW APPARATUS

New Gadget Indicates "World Time" for S-W Fans

● THE newest radio "gadget" issued by Alfred A. Ghirardi is his "Radio World-Time Indicator Gadget." Its purpose is to show at a glance the exact time for any radio program or news event in any part

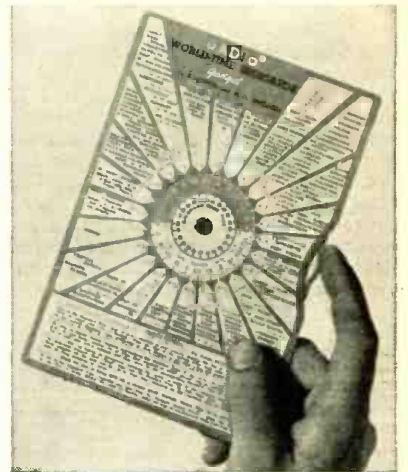

of the world. Readings are given for Standard, Daylight-Saving or Greenwich Mean Time. A turn of the dial enables the Short-Wave listener to tell when and where to tune in for any foreign or domestic radio program or event.

This article has been prepared from data supplied by courtesy of Radio & Technical Pub. Co.

Moderate-Price Multimeter

● THE Million Telegraph and Radio Laboratories has announced a line of pocket Volt-Ohm-Milliammeters at popular prices. Even the least expensive unit of the line uses a 3 in. D'Arsonval meter with a resistance of 1000 ohms per volt. The meter is calibrated for 0-5-50-500-1000 volts D.C., 0-1000-500,000 ohms, and 0-1 ma. The entire instrument is housed in a durable metal case 3 1/4" x 6" x 2".

This article prepared from data supplied by courtesy of Million Radio & Television Labs.



New Mike with Acoustic Compensator

● THE acoustic compensator makes the microphone immediately adjustable to close or distance pick up. By merely pushing the compensator up the pitch is raised. By lowering the compensator the pitch is lowered. Variations in room conditions are easily compensated for with the acoustic compensator.

Not to be confused with a tone control, the acoustic compensator is a mechanical shutter that gradually closes the back of the microphone. An air cushion is formed behind the ribbon which changes its operation from velocity to pressure.

This article prepared from data supplied by courtesy of the Amperite Company.

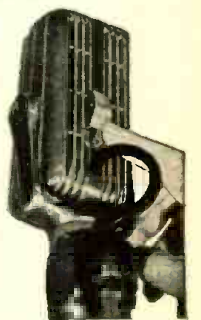

New Dynamic Mike

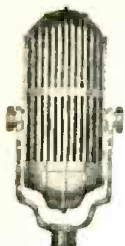

● A NEW unidirectional microphone has just been announced. It is available in two types: one of high impedance—10,000 ohms; the other of low impedance—50 ohms. This is a pressure velocity mike with pickup from one side only and a frequency response from about 50 to 5500 cycles. It is, of course, sturdy, immune to

weather conditions and adaptable to all circuits, as are other dynamic mikes. It is designed for use in public address and general sound installations as its uni-directional energy response reduces feed-back by two-thirds and also decreases extraneous pickup. Wind noises are scarcely audible on outdoor installations.

This information has been supplied through courtesy of American Microphone Co., Inc., Los Angeles, Calif.

New Capacitors Dykanol Filled

● HERMETICALLY sealed in round aluminum containers, the Type TLA new Cornell-Dubilier capacitors are impregnated and filled with fire-proof Dykanol, the same high dielectric impregnant as is used in the TJ-U transmitting capaci-



tors. The capacitors are designed for dependable operation in high-power amplifiers and medium-powered transmitters.

The staple characteristics of Dykanol permit the operation of these capacitors at 10% above rating without injury to unit.

This article has been prepared from data supplied by courtesy of Cornell-Dubilier Electric Corp.

Unique Small-Size Condensers

● A NEW line of small etched-foil tubular dry electrolytic condensers known as "Atoms" has been introduced by the Sprague Products Company. An 8 mf. 450 volt unit, for instance, is only 3/4" in diameter and 1 5/8" long.

These condensers are guaranteed to have extremely low leakage, exceptional shelf life and to withstand high surges. They are hermetically sealed—yet absolutely protected against "blow-ups" by an exclusive design feature.



These condensers are made in a complete line of voltages and capacities for practically any dry electrolytic requirement.

This article has been prepared from data supplied by courtesy of Sprague Products Co.

Stancor Announces Transmitter Kit

● A NEW (20-P) portable, self-contained transmitter kit, is the basis for a complete phone and C.W. transmitter, including power-supply, all contained in a cabinet 19" x 13" x 8 3/4" overall. Crystal controlled, this unit operates on any frequency from 1.6 to 60 mc. Frequency change is accomplished by 2 plug-in coils. Meter switching for all important circuits, and oscillator keying to permit break-in operation, are incorporated.

Punched chassis and front panel with full instructions are available from the manufacturer. Transformers and other components are all stock items, readily obtained at any distributor's.

This article has been prepared from data supplied by courtesy of Standard Transformer Corp.



New Television Tubes

● THE 1852 has extremely high grid-plate transconductance (900 micromhos). It is recommended for use in the r-f and i-f stages of the picture amplifier as well as in the first stages of the video amplifier when several video stages are used.

The 1853 is also a high transconductance tube (5000 micromhos). The transconductance of the 1853 is not as high as that of the 1852, because the 1853 is designed with an extended cut-off characteristic, so as to make it especially suitable for use in the r-f and i-f stages of the picture amplifiers of television receivers employing automatic gain control, according to RCA engineers.

The 832 is a new ultra-high-frequency transmitting tube incorporating two beam power units. It is intended primarily for service as a push-pull r-f power amplifier with maximum ratings at wavelengths as short as 2 meters, and with reduced ratings at wavelengths as short as 1 meter.

This article has been prepared from data supplied by courtesy of RCA Mfg. Co.

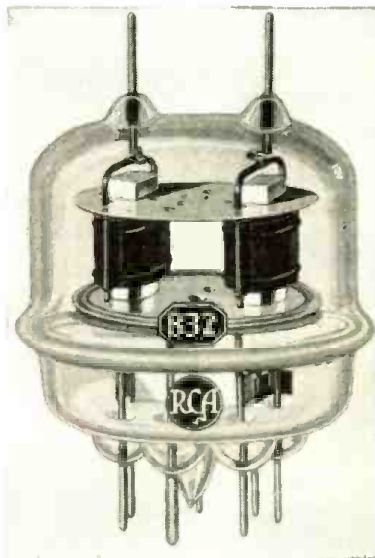

The Ralston Radio Code Course

● CONSISTS of three double-sided records and an excellent instruction book, which is invaluable for reference work.

Simplicity is the key-note of this method. The beginner has the advantage of an instructor at his call twenty-four hours a day. He may play the lessons as slowly as desired, and repeat each section of each lesson until it is thoroughly mastered. The instruction book follows his every step and leaves no question unanswered. The licensed amateur increases his speed and confidence.

This article prepared from data supplied by courtesy of Ralston Record Company.

CORNELL-DUBILIER OFFERS THE MOST COMPLETE CONDENSER CATALOG IN RADIO

FREE

New data, new designs, new types... every week uncovers some new C-D engineering development. Are you keeping abreast of capacitor progress? You'll find in this new catalog a wealth of information. Every one of its 40 pages illustrates and describes some new type capacitor. Cornell-Dubilier, world's oldest and largest exclusive manufacturer of capacitors, offers you this amazing catalog, thoroughly complete, representing the engineering experience of 28 years in the capacitor field at no cost. No amateur, experimenter, serviceman or engineer should be without it! Mail coupon for FREE copy today.

Are you on the C-D house organ mailing list? If not, check coupon for your copy.



CORNELL-DUBILIER ELECTRIC CORPORATION
1027 HAMILTON BOULEVARD
SOUTH PLAINFIELD, N. J.

CORNELL-DUBILIER ELECTRIC CORPORATION RT1135
1027 HAMILTON BOULEVARD, SOUTH PLAINFIELD, N. J.

Rush to me copy of Catalog 161
Put my name on list for house organ

Name.....

Address.....

City..... State.....

UNIDIRECTIONAL DYNAMIC

D9T

← BACK No Pickup
← FRONT Full Coverage
VOLUME INCREASED
by Reducing Feedback

D9T, List \$37.50, High Imp., 25' Cable.
D9, List \$35.00, Low Imp., 25' Cable.

Write for Catalogue No. 29

Manufacturers full line Dynamic, Crystal, and Carbon Microphones and Stands.

AMERICAN MICROPHONE CO., INC.
1915 So. Western Ave., Los Angeles, Calif.



MATH TABLES

\$1.25

Only \$1.25 for a complete set of practical, widely used mathematical tables containing four and five place logarithms,

squares, cubes, roots of numbers, differentials, integrals, algebraic and trigonometric formulae, trigonometric functions and their logarithms, interest tables, areas and circumferences of circles, and many others. Convenient pocket size, 5 1/4" by 7 3/4" inches. 320 pages bound in flexible Fabrikoid. For students, teachers, engineers, draftsmen and others. Moneyback guarantee.

CHEMICAL RUBBER PUBLISHING CO.
1934 W. 112th St., Cleveland, Ohio



EVERYTHING IN RADIO!

A COMPLETE SOURCE FOR YOUR RADIO NEEDS
Our immense stock of radio sets, parts and supplies enables you to purchase your entire needs on one order. You will find all your Nationally Known Favorites in this big book which is FREE for the asking. Practically every order is shipped the same day it is received. WRITE FOR BIG NEW CATALOG

BURSTEIN-APPLEBEE CO.
1012-14 McGee St. - Kansas City, Mo.

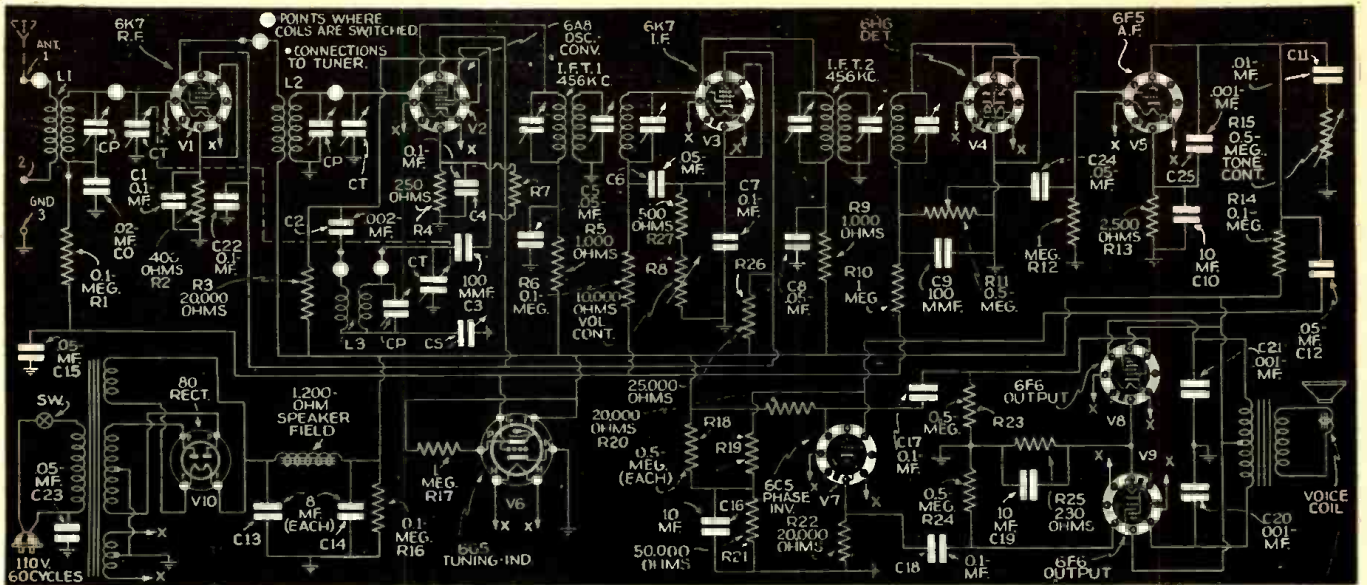

Fig. 1. Wiring Diagram of Browning 83 Receiver.

In the circuit diagram shown in Fig. 1, only one of the four sets of coils is shown, for the switching arrangement used in the "tuning catacomb" shorts and grounds all other coils except those actively in the circuit. This eliminates coil absorption and dead-spots in the tuning range and is essential for maximum performance. As will be noted in the circuit diagram, the I.F. transformers are made up of triple-tuned circuits which give a band-pass effect resulting in less cutting of side-bands and unusually fine quality. The selectivity curve

The Browning 83

(Continued from page 407)

of this I.F. amplifier is shown in Fig. 2. Note that the sides of the curve are unusually steep while the nose of the curve is broad. Thus a near approach is made towards the perfect I.F. amplifier response characteristics which would have a square nosed curve with vertical sides.

Diode detection is utilized and automatic volume control is obtained from the diode

detector circuit. The bias on the r.f. and I.F. tubes is controlled with the automatic volume control but not the mixer tube, as this may result in slight frequency shift, especially on the high frequency bands. A phase-inversion, push-pull audio system is incorporated, which only requires that the two 20,000 ohm resistors in the plate and in the cathode circuit of the 6C5 tube be accurate in order to obtain true phase-inversion. Thus, the two voltages developed on the grids of the 6F6 output tubes must be equal regardless of changes in tube char-

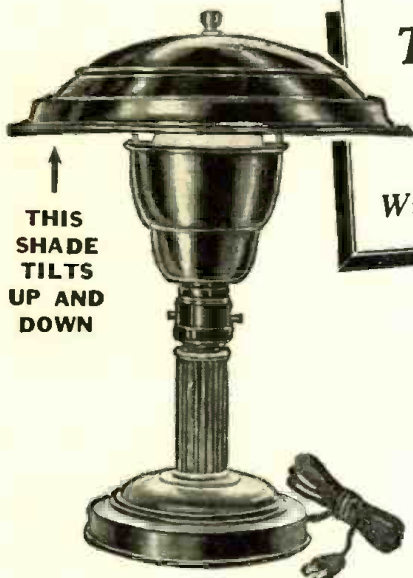

↑
THIS SHADE TILTS UP AND DOWN

This MODERN DESK LAMP
Is Yours Absolutely FREE
With a Year's Subscription to RADIO & TELEVISION

JUST THINK OF IT—you can get absolutely FREE, the beautiful desk lamp shown at the left. This attractive desk lamp is suitable for home, desk, den, office, laboratory, studio or workshop. It is sent to you by the publishers with their compliments for a one-year subscription to RADIO & TELEVISION. Look at the many fine features which this handsome desk lamp has. Read the list below.

LOOK AT THESE FEATURES!

- ⊗ Constructed of metal with attractive bronze finish.
- ⊗ Scientifically constructed to give glareless, diffused light.
- ⊗ Helmet-type shade can be tilted to any convenient angle.
- ⊗ Stands 13" high and has 10" metal shade.
- ⊗ 5-foot rubber insulated cord and plug.
- ⊗ Constructed to last for many years.

Clip Coupon Today — and Mail!

Send your subscription today to RADIO & TELEVISION for One Year (12 issues) and receive absolutely FREE one of these truly remarkable desk lamps. New subscribers are accepted or you may extend your present subscription another twelve months under this offer. Mail your remittance of \$2.50 (Plus 25c for shipping charges on lamp) to the publishers of RADIO & TELEVISION. (Canada and foreign \$3.25) You will promptly receive your FREE DESK LAMP by return mail. Use the coupon at the right to order your subscription.

RADIO & TELEVISION

99 Hudson Street

New York, N. Y.

RADIO & TELEVISION, 99 HUDSON ST., NEW YORK, N. Y.

Gentlemen: Enclosed you will find my remittance of \$2.50 for which enter my subscription to RADIO & TELEVISION for One Year (12 issues). Send me promptly my FREE DESK LAMP. (Canada and foreign \$3.25.) In U. S. add 25c additional to cover shipping charges of lamp.

() NEW SUBSCRIBER

() EXTEND PRESENT SUBSCRIPTION

Name

Address

City

(Send remittance by check, money order or unused U. S. Postage stamps. Register letter if you send cash or stamps.)

R&T-113R

acteristics. The overall audio response characteristics of the receiver are shown in Fig. 3. These were obtained by impressing on the antenna circuit a carrier frequency modulated at various audio frequencies from 30 to 10,000 cycles and measuring the a.c. voltage developed from plate to plate of the 6F6 output tubes. It will be noted that with the tone control retarded the voltage output at frequencies from 30 to 7,000 cycles is flat to within about 6 d.B. This unusually fine response characteristic is due to the band-pass effect of the I.F. amplifier and to the design of the audio amplifier, the latter of which has in itself a slight rising amplification as the frequency is increased. The

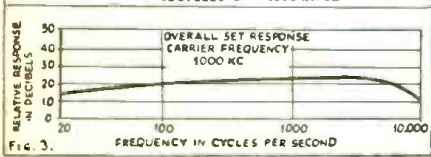
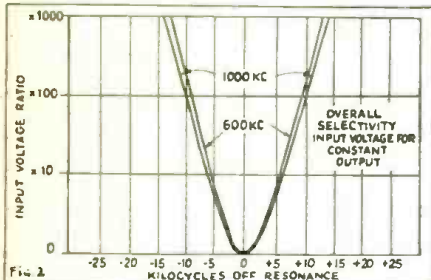

Figs. 2 & 3. Resonance and response curves.

tone control is so designed that if the higher frequencies are not desired, the response characteristics of the set can be changed by advancing the tone control so as to eliminate audio frequencies above 3,000 cycles.

As will be noted, the audio system comprises two 6F6 tubes in push-pull which have an output of more than 10 watts, sufficient for any home requirement and, in fact, ample for small halls. A tuning eye which indicates the strength of the carrier signal is connected to the automatic volume control system. This materially assists in tuning in stations so as to assure the fine quality which the receiver is capable of producing.

The complete kit has been so designed that only a screwdriver, a pair of pliers, and a soldering iron are necessary for completely assembling the parts as well as making final alignment.

Final Adjustments

The intermediate frequency transformers have been preadjusted at the laboratories to frequencies of 456 kc. However, due to lead and tube capacitance, slight final adjustments will be necessary. The link circuit which is adjusted by the middle screw

on IFT1 and IFT2 should not be changed as these circuits are only connected to ground, and tube and lead capacitance have no effect upon their tuning. Thus these circuits are a key to the alignment of the I.F. amplifier at the correct frequency. To make the final alignment on the I.F. amplifier, proceed as follows: With the set in operating condition and an antenna connected, tune in a station, preferably on the broadcast band. Adjust the top and bottom screws on IFT1 and IFT2 until maximum signal is obtained. Reduce the length of the antenna and realign the above circuits. When the I.F. transformers have been properly aligned, a "hiss" will be obtained without the antenna connected. When the I.F. transformers have been adjusted, the trimmers in the Tuner may be slightly adjusted to take care of wiring capacities. With the receiver in an operating condition and the antenna disconnected, these adjustments may be made in the following manner:

Set the band selector switch on Band 4 and fully advance the I.F. and audio volume control.

Set the pointer at approximately 1.4 mc. and with an insulated screwdriver, adjust the trimming condensers on the antenna and R.F. coils for maximum "hiss."

It is inadvisable to change the adjustment on the oscillator trimmers as this controls the frequency calibration of the dial.

The final adjustments on the other bands may be made in a similar manner by simply changing the band selector switch to each band in turn and making adjustments on the antenna and R.F. trimmers.

Extra holes have been provided in the chassis for the addition of various other circuits which the experimenter might wish to incorporate. Thus a noise suppression system may be readily installed and a beat frequency oscillator may be easily added for CW operation.

This article prepared from data supplied by courtesy of Browning Laboratories, Inc.

Interesting articles to be found in the current issue of

Radio - Craft:

- Electronic Organ Helps Dit-Dah Boys!
 - Beginners' "Breadboard Special"—I-Tube High-Gain, All-Wave Set, N. H. Lessem.
 - Cash-In on Your Radio Education.
 - Build this Pocket-Size, 3-Tube Hearing Aid, Howard G. McEntee.
 - Wire-Less Public Telephones on Wheels! ". . . By Electrical Transcription"
 - Developments Increase Radio's Vocational Appeal.
 - 15 New Tubes!—R. D. Washburne.
- The current, November issue of RADIO-CRAFT is for sale on all newsstands October 1.

Push-Button Band-Change

(Continued from page 407)

sibility of the field creating undesirable hum.

The power-supply is designed with economy in view and uses a type 80 rectifier. A low-priced half-shell transformer is employed; and the choke of comparatively high d.c. resistance (600 ohms) in order to reduce the plate potential to about 200 volts. A total of 24 mf. capacity does a good filtering job.

First, the I.F. transformers should be aligned to 456 kc. Then, beginning with the broadcast band, follow this alignment procedure for all bands. Set oscillator coil trim-

mer to secure highest frequency of the band. Tune in signal using the higher frequency alignment point given. (B.C. band 1400 kc.) Align antenna coil for maximum response. Tune in lower alignment point given and adjust oscillator series padding condenser while "rocking" the gang condenser. Proper setting of series padding condenser will give maximum output at lowest frequency alignment point. Recheck higher frequency alignment and make readjustments if necessary. Check back on lower frequency, and re-adjust padding condenser for best results.

This article prepared from data supplied by courtesy of Allied Radio Corporation.

USE IT WHEREVER RESISTANCE MEASUREMENTS ARE INVOLVED



4 3/4" diameter by 3 1/4" high

RESISTANCE ANALYZER and INDICATOR

A Calibrated Variable Resistor Instrument for General Use on All Types of Resistance Measurements.

- Valuable to Servicemen
- Amateurs
- Radio & Electrical Engineers
- Manufacturers
- Experimenters
- Laboratories
- Colleges & Schools
- Broadcast Stations

The utility value of the new IRC Resistance Analyzer and Indicator is quickly evident. It has a multiplicity of uses, some of the most important being for determining by the substitution method proper values for resistors and standard Volume Controls; estimating required Volume control tapers; voltmeter multipliers; wire wound rheostat or potentiometer; calibrated gain control or attenuator; voltage divider, etc. Complete instructions in 16-page folder.

New—Trouble-Free—Practical

The Analyzer is direct reading. It has only the one adjustment knob to vary the resistance continuously from 0 to 1.0 megohm. Circuit consists of heavy duty wire wound rheostat type element from 0 to 30,000 ohms and special Metallized type resistance element from 30,000 ohms to 1.0 megohm. Case of molded bakelite. Three fuse sizes included.

Net Price \$4.95

INTERNATIONAL RESISTANCE COMPANY
101 NORTH BROAD STREET, PHILADELPHIA, PA.

A FREE BOOK FOR EVERYONE IN RADIO

RADIO-CRAFT brings you all phases of radio—servicing, public address, set construction, electronics, facsimile, etc. Features popular departments as Latest in Radio—New Tubes—Data Sheets—Television—Operating Notes, etc. Over 175 illustrations in every issue.

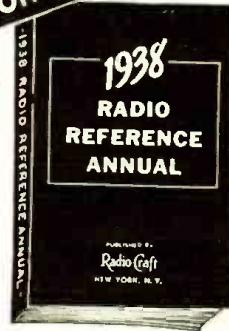

To readers of this announcement we present a SPECIAL OFFER—Seven Months' Subscription to RADIO-CRAFT and a FREE copy of the 64-page 1938 RADIO REFERENCE ANNUAL for One Dollar. New subscribers welcome—old subscribers can extend their present subscription seven months.

Remit ONE DOLLAR by check, money order or stamps for your FREE BOOK and Seven Months' Subscription to RADIO-CRAFT.

RADIO-CRAFT, 997 HUDSON STREET, NEW YORK, N. Y.

A NEW Field of Profit for SMART Radio Servicemen....

SHORTWAVE HOME DIATHERMY

Here's an absolutely new field to make money. Become one of our authorized agents with this marvelous shortwave diathermy machine. Fool-proof, approved, portable! Agents all over cleaning up. Get on the band-wagon and let us tell you how. Still some exclusive territory left. WRITE AT ONCE.

Our Best agents are those with Radio Sales and Service Experience.

SCIENTIFIC DIATHERMY CORP.
200 W. 34th St., Dept. RT-11, New York City

FOUR NEW 10¢ RADIO BOOKS

RADIO FANS EVERYWHERE—these little ten cent text books give you an excellent foundation for the study of radio. They are clearly written, profusely illustrated and contain over 15,000 words in each book. You'll be amazed at the wealth of information these volumes have. They are handy for review or reference books.

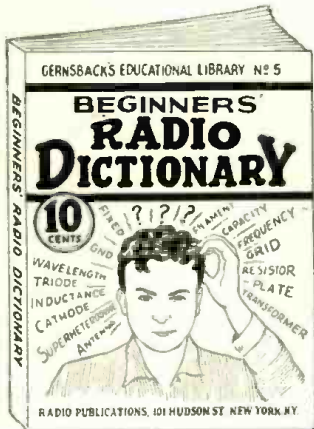

NO. 5—BEGINNERS' RADIO DICTIONARY

Are you puzzled by radio language? Can you define frequency? Kilocycle? Tetrote? Screen grid? Baffle? If you cannot define these very common radio words and dozens of other, more technical, terms used in all radio magazines and instruction books, you need this book in your library. It's as modern as tomorrow—right up to the minute. It tells you in simple language just what the words that puzzle you really mean. You cannot fully understand the articles you read unless you know what radio terms mean. This is the book that explains the meanings to you. Can you afford to be without it, even one day longer?

**FAMOUS
GERNSBACK
EDUCATIONAL
LIBRARY**

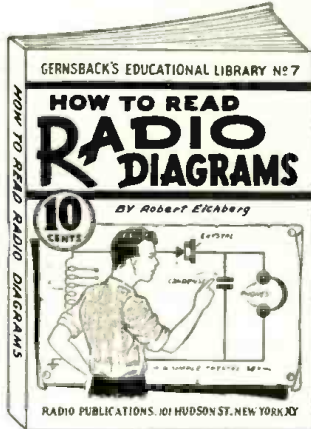

NO. 7—HOW TO READ RADIO DIAGRAMS

All of the symbols commonly used in radio diagrams are presented in this book, together with pictures of the apparatus they represent and explanations giving an easy method to memorize them. This book, by Robert Eichberg, the well-known radio writer and member of the editorial staff of RADIO-CRAFT magazine, also contains two dozen picture wiring diagrams and two dozen schematic diagrams of simple radio sets that you can build. Every diagram is completely explained in language which is easily understood by the radio beginner. More advanced radio men will be interested in learning the derivation of diagrams, and the many other interesting facts which this book contains.

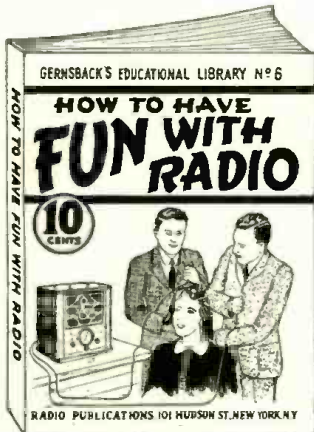

NO. 6—HOW TO HAVE FUN WITH RADIO

Stunts for parties, practical jokes, scientific experiments and other amusements which can be done with your radio set are explained in this fascinating volume. It tells how to make a newspaper talk—how to produce silent music for dances—how to make visible music—how to make a "silent radio" unit, usable by the deafened—how to make toys which dance to radio music—sixteen clever and amusing stunts in all. Any of these can be done by the novice, and most of them require no more equipment than can be found in the average home. Endless hours of added entertainment will be yours if you follow the instructions given in this lavishly illustrated book.

**ADDS
FOUR
NEW
BOOKS!**

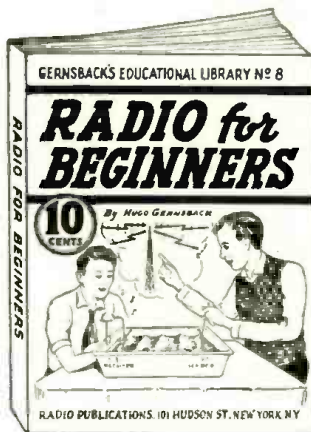

NO. 8—RADIO FOR BEGINNERS

Hugo Gernsback, the internationally famous radio pioneer, author and editor, whose magazines, SHORT WAVE & TELEVISION and RADIO-CRAFT are read by millions, scores another triumph with this new book. Any beginner who reads it will get a thorough ground work in radio theory, clearly explained in simple language, and through the use of many illustrations. Analogies are used to make the mysteries of radio as clear as "2+2 is 4". It also contains diagrams and instructions for building simple radio sets, suitable for the novice. If you want to know how transmitters and receivers work, how radio waves traverse space, and dozens of other interesting facts about this most modern means of communication, this is the book for you!

Other Titles in This Series!

Four other volumes in this ten-cent radio book series—each on a popular subject—are available. The titles are:
No. 1—HOW TO BUILD A DOERLE SHORT-WAVE SETS
No. 2—HOW TO MAKE THE MOST POPULAR ALL-WAVE 1- AND 2-TUBE RECEIVERS
No. 3—ALTERNATING CURRENT FOR BEGINNERS
No. 4—ALL ABOUT AERIALS

BOOKS ARE ALL UNIFORM

Every book in the GERNSBACK EDUCATIONAL LIBRARY has 32 pages—with illustrations varying from 30 to 66 in number. Each title volume contains over 15,000 words. Positively radio's greatest book buys! If you do not think these books worth the price asked, return them in 24 hours and your money will be instantly refunded.

RADIO PUBLICATIONS
101 HUDSON STREET NEW YORK, N. Y.

World S-W Stations

(Continued from page 432)

Mc.	Call	Station
6.130	LKL	JELOY, NORWAY, 48.94 m. 11 am.-6 pm.
6.125	CXA4	MONTEVIDEO, URUGUAY, 48.98 m., Addr. Radio Electrico de Montevideo, Mercedes 823. 10 am.-12 n., 2-8 pm.
6.122	HJ3ABX	BOGOTA, COL., 49. m., Addr. La Voz de Col., Apartado 26-65. 12 n.-2 pm., 5:30-11 pm.; Sun. 6-11 pm.
6.122	HP5H	PANAMA CITY, PAN., 49 m., Addr. Box 1045. 10 am.-1 pm., 5-11 pm.
6.120	W2XE	NEW YORK CITY, 49.02 m., Addr. Col. B'cast. System, 485 Madison Ave. 10:30-11:30 pm.
6.117	XEUZ	MEXICO CITY, MEX., 49.03 m., Addr. 5 de Mayo 21. Relays XEFO 1-3 am.
6.115	OLR2C	PRAGUE, CZECHOSLOVAKIA, 49.05 m. (See 11.49 mc.)
6.110	XEGW	MEXICO CITY, MEX., 49.1 m., Addr. La Voz de Aguila Azteca desde Mex., Apartado 8403. Relays XEJW 11 pm.-1 am.
6.110	VPB	COLOMBO, CEYLON, 49.1 m. Daily 7-9:30 am; Sun. 6:30-9:30 am.
6.108	HJ6A8B	MANIZALES, COL., 49.14 m., Addr. P. O. Box 175. Mon.-Fri. 12:15-1 pm.; Tue. and Fri. 7:30-10 pm.; Sun. 2:30-5 pm.
6.100	YUA	BEGRAD, JUGOSLAVIA, 49.18 m. 12:45-2:30, 4-8 am., 1-6 pm.
6.100	W3XAL	BOUND BROOK, N. J., 49.18 m., Addr. Natl. Broad. Co. 8 pm.-12 m.
6.100	—	NOUMEA, NEW CALEDONIA, 49.18 m., Radio Noumea, Addr. Charles Gaveau, 44 Rue de l'Alma. 2-3:30 am., exc. Sun. and Mon.
6.097	ZRK	KLIPHEUVEL, S. AFRICA, 49.2 m., Addr. S. African Broad. Co., Johannesburg. Daily 12 n.-4 pm., Sun. 12 n.-3:20 pm.
6.097	ZRJ	JOHANNESBURG, S. AFRICA, 49.2 m., Addr. S. African Broad. Co. Daily exc. Sat. 11:45 pm.-12:50 am.; Daily exc. Sun. 3:15-7:30, 9-11:30 am. (Sat. 8:30-11:30 am.) Sun. 3:30-4:30 or 4-5 am., 5:30-7, 9-11:30 am.
6.095	JZH	TOKYO, JAPAN, 49.22 m., Addr. (See 11.800 mc., JZJ.) Irregular.
6.090	CRCX	TORONTO, CAN., 49.26 m., Addr. Can. Broadcasting Corp. Daily 7:45 am.-5 pm., Sun. 10:30 am.-12 n.
6.090	ZBW2	HONGKONG, CHINA, 49.26 m., Addr. P. O. Box 200. Irregular.
6.083	VQ7LO	NAIROBI, KENYA, AFRICA, 49.31 m., Addr. Cable and Wireless, Ltd. Mon., Fri. 5:30-6 am., 11:15 am.-2:15 pm., also Tues. and Thurs. 8:15-9:15 am.; Sat. 11:15 am.-3:15 pm.; Sun. 10:45 am.-1:45 pm.
6.081	YVIRD	MARACAIBO, VEN., 49.32 m. 6-11 pm.
6.080	W9XAA	CHICAGO, ILL., 49.34 m., Addr. Chicago Fed. of Labor. Relays WCFL irregular.
6.079	DJM	BERLIN, GERMANY, 49.34 m., Addr., Broadcasting House. Irregular.
6.077	OAX4Z	LIMA, PERU, 49.35 m. Radio National 7-11 pm.
6.075	VP3MR	GEORGETOWN, BRI. GUIANA, 49.35 m. Sun. 7:45-10:15 am.; Daily 4:45-8:45 pm.
6.070	HP3ABF	BOGOTA, COL., 49.42 m., La Voz de Bogota.
6.070	CFRX	TORONTO, CAN., 49.42 m. Relays CFRB 7:30 am.-12 m., Sun. 10 am.-12 m.
6.070	VE9CS	VANCOUVER, B. C., CAN., 49.42 m. Sun. 1:45-9 pm., 10:30 pm.-1 am.; Tues. 6:30 pm., 11:30 pm.-1:30 am. Daily 6-7:30 pm.
6.069	—	TANANARIVE, MADAGASCAR, 49.42 m., Addr. (See 9.53 mc.) 12:30-12:45, 3:30-4:30, 10-11 am., Sun. 2:30-4:30 am.
6.065	SBO	MOTALA, SWEDEN, 49.46 m. Relays Stockholm 1:30-5 pm.

Those interested in lower-frequency stations may refer to previous issues.

MAIL COUPON TODAY!!

RADIO PUBLICATIONS, Dept. R&T-11-38
101 HUDSON STREET, NEW YORK, N. Y.

Gentlemen: Please send immediately, POSTPAID, the book numbers circled below. I am enclosing...cents—each book being 10c.

Send FREE listing of 48 new 10c publications.

Name

Address

City State

Remit by check or money order—register letter if you send cash or unused U. S. postage stamps.

Flat-Top Beam Antenna

(Continued from page 398)

tion should result if the dimensions are not carried out to the inch.

The approximate coverage of a 2-section flat-top beam oriented approximately north and south at Washington, D. C., is shown in Figure 2. The chart used is a great circle map of the world with Washington at the center. Straight lines drawn through Washington are great circles, and give the distance and direction of any part of the world from Washington. Although this map is centered on Washington and is exactly correct only for this one point, the map can also be used with fair accuracy for most locations in the eastern part of the United States when these are taken as the "center." It is important in erecting a beam antenna to orient it properly for the locality it is desired to receive. A great circle map such as the one in Figure 2 is of assistance in doing this. A globe is also very helpful.

The antenna of Figure 2 was turned so that the middle of the beam is centered on Sydney, Australia, giving the maximum pick-up to signals arriving from this direction and also from the opposite direction eastward. In addition to stations lying on the center-line of the beam, there will be improvement also in the reception of stations lying considerably off this line.

The shaded area in Figure 2 indicates a coverage over an angle of 60 degrees in each direction broadside to the antenna, over which there should be an improvement in reception as compared to a half-wave antenna. Over an angle of about 100 degrees, there will be quite good reception. Lines indicating this coverage are also shown on Figure 2.

Thus, the antenna whose coverage is shown in Figure 2 receives the best stations in the southwestern part of the United States, Hawaii, New Zealand, Eastern Australia, Africa, and southern Europe. Its minimum response is in the direction of South America and Asia. A second beam oriented at right-angles would give best response to South America and Asia and rather complete world coverage would be afforded by the two beams. Another possibility for increasing the coverage is to use a directivity switching arrangement, as will be described.

Since much of the improvement of a flat-top beam is the result of a greater response at lower vertical angles, these antennas normally show the greatest improvement in the reception of extreme long-distance signals coming from directions broadside to the flat-top.

Construction of the Antennas

The general construction of the antennas is indicated in Figure 1. Three spreaders of light wood (1 inch by 1 inch in cross-section) or bamboo are used to give the 10 foot 5 inch spacing. By means of a yoke of rope at each end, the array can be suspended between two poles or supports. If these yokes are made long enough, there will be very little tendency for the end spreaders to bow. By adjusting the point where the rope from the pole connects to the yoke, the antenna can be made to hang horizontally, that is, not tilt sideways. The use of good insulation and solid electrical connections is very important.

The cross-over at the center of the antenna can be conveniently accomplished by means of 6-inch porcelain or ceramic feeder-spreader insulators. The end-fed antenna requires one mounted vertically at the middle of the center spreader as shown

in Figure 1-A. The center-fed flat-top requires two such insulators, one mounted horizontally at the center and one vertically half way from the center to one end. The feeders going to the receiver connect to this antenna at the center feeder-spreader insulator. In addition to these insulators, eight other glass or ceramic strain insulators are required for the long flat-top wires, and in the case of the end-fed antenna, two more such insulators at the middle of the end-spreader to support the feed line. If desired, the center wooden spreader of the end-fed flat-top can be omitted.

The Feeders and Coupler

The feeders and antenna may be constructed of number 12 (B. & S. gauge) copper wire. Porcelain or ceramic spreaders 4 or 6 inches long and spaced every 3 to 5 feet can be used for the feed line. Or if it is desired to reduce the feeder pick-up to a minimum, a transposed line with 2 inch spacing may be employed. The feeders should be well insulated where they enter the building. Twisted pair feeders should not be used with these antennas.

The feed line from the antenna is connected to the receiver through a coupling unit. Two types of couplers are shown in Figure 1. Either type may be used with either antenna. The type of coupler employed depends only on the length of the feeders. When the feeders are somewhat more than an odd number of quarter wavelengths long, that is, approximately 20, or 50 feet long, a series tuned coupler can be used as shown in Figure 1-B. With feeders somewhat more than an even number of quarter wavelengths long, that is, approximately 35, 70, or 100 feet long, a parallel tuned coupler can be used as illustrated in Figure 1-A.

The feeders need not be exactly of the lengths indicated, but may be several feet more or less. In fact, it may be found possible, by means of either one type of coupler or the other, to tune the antenna system for nearly any length of feed line. However, it is generally not advisable to use feeders of this type, that is Zepp feeders, which are much more than 100 feet long.

For use on 14 mc. the condensers, C, of the couplers may be 50 to 100 micro-microfarads or greater capacitance. The coil, L, may be constructed of about 15 turns of number 12 copper wire, space wound on a 1 to 2 inch cardboard or ceramic form. Connection to one side of the coil should be made by means of a clip so that fewer turns can be used if required. As few as 5 or 6 turns may actually be used. These values are merely suggestions since a large variety of coil and condenser combinations are possible. The center of the coupler coil, L, may or may not be grounded, depending on whichever is found to work better.

The "link" connecting the coupler to the receiver can consist of two or three turns of "push-back" or other insulated wire wound around the center of the coupler coil, L. This link connects to the "doublet" input terminals of the receiver.

Tuning the Coupler

In operating the parallel tuned coupler, the condenser is varied until maximum receiver output is obtained. Tuning the condenser should "peak" the signal being received. That is, there should be a condenser setting which results in a maximum signal and tuning the condenser to either greater or less capacitance should cause a decrease

(Continued on following page)



TRIPLET

MODERN LONG SCALE PRECISION INSTRUMENTS

18 CASE STYLES

2" to 7"

Accuracy 2%



Model 327

3" instrument designed for flush-mounting; molded case.

Today's most modern instruments... 18 styles to fit individual taste... at popular prices.

New methods and extremely accurate processes are embodied in Triplet instrument designs. An example is the long research in developing a super-magnet (the heart of the instrument) by means of which it has been possible to eliminate extra pole pieces. This achievement has brought from prominent laboratories, graphs that prove Triplet magnets give more uniform scale characteristics and a higher degree of dependability.

Be Sure to Enter Triplet's \$500.00 Radio Service Puzzle Contest! Write for Information.

TRIPLET ELECTRICAL INSTRUMENT CO.
2811 Harmon Drive, Bluffton, Ohio

CASH IN

ON YOUR SPARE TIME!

300 WAYS TO MAKE MONEY

ONLY

25c

Per Copy



SOLD ON A MONEY-BACK GUARANTEE!

25 CENTS

BRAND NEW BOOK

40,000 WORDS IN TEXT!

In "CASH IN" you get ALL the real money-makers — dozens of profitable tested mail order plans, confidential business secrets, dozens of practical tested formulas, successful tested schemes — actual experiences of men who have started on a shoestring — with less than \$10 capital.

Buyers of This Book Tell Us—

"Biggest value I've yet to see. Book is worth at least a dollar." S. BUDA, B'klyn, N. Y.

"Your book is as good if not better than others selling at \$1.00."

GEORGE BRUNET, Montreal, Can.

"CASH IN is the best value I have yet to see in the mail order field."

LAWRENCE FOX, Brooklyn, N. Y.

"CASH IN" contains only tested ideas covering every type of full—or spare-time enterprise—it's a "masterpiece" in business ventures.

25 CENTS per copy. Sent POSTPAID anywhere upon receipt of 25 cents U.S. stamps or coin.

NATIONAL PLANS INSTITUTE

246-T FIFTH AVENUE

NEW YORK, N. Y.

in signal strength. If the coupler is "peaked" or resonated on a station in the center of the 14 mc. amateur band, this setting will usually suffice for the whole band, but some retuning at the edges of the band may be helpful on weak signals. By adjusting the coupler condenser and coil to resonance, the antenna can be used effectively on frequencies considerably removed from the 14 mc. band.

The operation of the *series tuned* coupler is similar to the parallel, except that two condensers instead of one must be tuned. These are normally adjusted so that each has about the same capacitance as the other. The two can be ganged to operate on one shaft if desired, but the rotors of the condensers must be insulated from each other in this case.

Transmitting: Couplers of the type described can also be used with the flat-top beam for *transmitting*. In this case the coupler coil is linked to the final amplifier tank circuit. For transmitting, of course, the condensers should be of sufficiently high voltage rating. Also heavier copper wire such as number 14 or 12, insulated, should be used for the link.

Directivity Switching

In addition to operation as flat-top beams, with maximum response *broadside* to the flat-top, the antennas of Figure 1 can also be converted to operate similar to a long wire type and give fairly good reception *off the ends* of the flat-top. The end-fed

Flat-Top Beam Antenna

(Continued from preceding page)

flat-top of Figure 1-A is better adapted for this use. The parallel tuned coupler is used for *directivity switching*. The series tuned type is not as readily adapted for this purpose.

The change-over is made by connecting both feeder wires together to one side of the coupler coil, rather than connecting one feeder to each side as for flat-top beam operation. A single-pole-double-throw switch can be used for making the change as shown in Figure 1-A. With this switch in the "up" position the antenna operates as a flat-top beam. When thrown to the "down" position, the feeders are connected together (in parallel) and the antenna no longer works as a beam, but rather in a manner similar to a long wire. In this latter case, the feed line acts as part of the antenna in picking up the signal.

The directional characteristics of the antenna when used with the feeders in parallel (switch down) will *not* be the same as when the antenna operates as a beam. The antenna of Figure 1-A will probably be found to be quite responsive to signals arriving from the general direction of the ends of the flat-top when used *with the feeders in parallel*. Since the antenna, when operated as a beam, has its minimum response in these directions, a considerable improvement in the strength of signals *off*

the ends of the flat-top may be experienced when going from "beam" to long wire operation. Thus, with the switch "up," stations broadside will be received best and with the switch "down," stations off the ends will be favored. By operating the switch, it may be possible to tell in a general way from which direction the signal being received is coming. It may be necessary to retune the coupler condenser when going from one condition to the other.

The *directivity switching* works to best advantage with the end-fed flat-top but the center-fed type can also be used in this way. In either case, the feeders should be somewhat more than an even number of quarter-wavelengths long as shown in Figure 1-A. Directivity switching of this type with a flat-top beam has been described by Robert R. Sproule, W8QJT.³

In general, the *directivity switching* is useful where only one antenna is available and it is desired to receive stations off the ends of the flat-top in addition to broadside. The best response of the antenna will be to the broadside stations when operated as a beam. When used as a long wire antenna, the system will not have as much gain, but, in contrast to the minimum response of the beam to stations off the ends of the flat-top, will give marked improvement in the reception of stations in these directions.

Unless the flat-top beam is properly tuned-up, it may not operate as it should.

(Continued on page 442)

³See "Radio" for Jan. 1938.

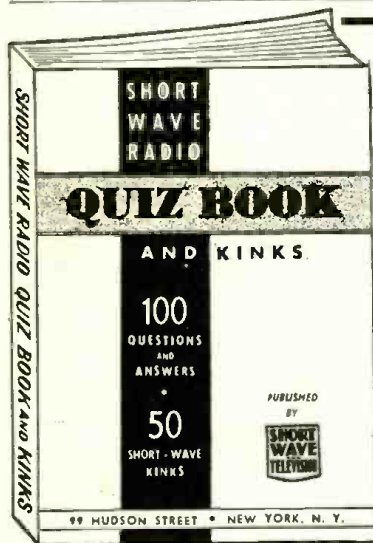

Questions and Answers Covering S-W transmitters.
 Questions and Answers Covering S-W Receivers.
 Ultra-Short-Wave Transmitters and Receivers.
 S-W "Kinks"—Short-cuts and Practical Wrinkles, Coil Winding Data.
 How to Add an Audio Amplifier to a Small S-W Receiver.

How to Connect an R.F. Stage Ahead of Your Present Receiver.
 Dozens of Novel New Hook-Ups for the S-W Experimenter.
 Clear diagrams showing how to connect the latest type tubes in place of your old tubes, so as to obtain greater DX.

HOW TO "HOOK UP"—
 S-W Converters
 Noise Silencers
 Power supplies
 Modulators
 Beat Oscillators
 Antennas
 Pre-selectors
 5-meter receivers

Contents of the "QUIZ BOOK"

FREE BOOKS—AND HOW YOU

CAN GET THEM!

HERE is a brand new book—with an unusually interesting content. The text—prepared by the Editorial Staff of RADIO AND TELEVISION, contains a variety of material which only experts could select and incorporate in such an excellent volume.

"SHORT WAVE RADIO QUIZ BOOK AND KINKS" cannot be bought—it is sent to you absolutely FREE with your subscription to RADIO AND TELEVISION at the Special Rate of Seven Months for One Dollar. (Old subscribers may get this book by extending their subscription.) The book contains 64 pages with a heavy flexible colored cover. It measures 5½ x 8½ inches, and includes hundreds of photographs and diagrams. The contents are outlined below.

RADIO AND TELEVISION • 99 Hudson Street • NEW YORK, N. Y.

R&T-1138
 Gentlemen: Enclosed you will find my remittance of \$..... for which enter my subscription to RADIO AND TELEVISION as checked below; also send me, Postpaid, the book or books which I have marked at the right.
 7 months—\$1.00—choice of any one of three (3) books. (Canadian and foreign—\$1.30)
 14 months—\$2.00—choice of any two (2) of the three (3) books. (Canadian and foreign—\$2.60)
 21 months—\$3.00—all three books. (Canadian and foreign—\$3.90)
 If you are a subscriber now, we will extend your present subscription.
 New subscriber Old subscriber

Name..... Address.....
 City..... State.....

Send your remittance by check or money order. If you send cash or unused U.S. postage stamps, please be sure to register your letter for your own protection.

- S.W. RADIO QUIZ BOOK AND KINKS
 ABC OF TELEVISION
 SHORT WAVE GUIDE

2 Other FREE Books ABC OF TELEVISION



Contains latest material on Television developments. It covers theory of scanning; simple television receiver, how the eye sees; the photo-electric cell; neon lamps; need for broad channel width in transmission of high-fidelity television signals; cathode ray tube and television receiver; Farnsworth system of television transmission, and other important features.

SHORT WAVE GUIDE

Covers hundreds of Short-wave questions and answers; illustrates popular Short-Wave "kinks"; gives instructions for building simple Short-Wave receivers; instruction on the best type of antenna to use; diagram and construction details for building a simple "ham" transmitter; practical hints on Short-Wave tuning.



The Radio Beginner

(Continued from page 399)

around the first nail, generates a magnetic field, which is picked up by the coil wound about the second nail, and then reconverted into an electric current as shown on the galvanometer. The distance over which this transfer of energy will take place depends upon the distance of the coils from each other, the strength of the battery, the size of the coils, etc. Transmitting energy in this fashion from one coil to another is called *electro-magnetic induction*.

If we were to look at our galvanometer indicating needle, we would find that it moved (thus indicating a current flow) only at the moment when we *either connected or disconnected* the battery. In other words, we secured a transfer of energy only when the magnetic field about the first coil was building up, or collapsing. Were it not for this fact, the production of an electric current would indeed be a very simple matter. This can better be understood by repeating our experiment but in a slightly different manner. Since the function of the first part of our hook-up (that is, the first coil and the battery) is solely to produce a magnetic field, we may use a permanent bar magnet (see Fig. 3) which has a magnetic field about it.

If we push the bar magnet into the coil connected to the galvanometer we will get a reading, indicating the passage of an electric current. The moment we remove the bar magnet, we will again get a galvanometer reading. If, however, we keep the bar magnet still, the galvanometer needle will come to rest, indicating no current flow. Work must be done, before we can transform electro-magnetic energy into an electric current. If simply putting a magnet inside of a coil of wire would produce a continuous current of electricity, we would not need to burn coal or use water power to turn our generators.

We have often heard the terms: *direct current* and *alternating current*, or used their abbreviations—A.C. and D.C. By direct current we mean an electric current that flows continuously in *one direction*.

Alternating Current

Alternating current is a bit more difficult to understand, chiefly due to the use of what are known as *plus* and *minus* symbols. Let us take the case of an ordinary twelve inch ruler, for example. It starts at the extreme left hand side with zero, then continues to one inch, two inches, etc., until all the way over on the right hand side we reach the marking of twelve inches. We could, if we wished, continue to extend the ruler to read thirteen, fourteen inches, etc. This would be the right hand side of the ruler. But what about the left hand side? We could also extend the left hand side, starting from zero, and then count off one inch, two inches, three inches, etc. But we would have to distinguish these markings from those on the right hand side. Hence, by convention we agree to call those on the left of zero, **MINUS**, and those on the right of zero, **PLUS**. The use of the word minus is perhaps unfortunate since the word ordinarily implies a "taking away from something." In this case, it is important to remember it simply indicates *direction*. When we say one or two inches minus, we merely mean a certain distance to the left of zero. When we say minus two volts, we merely indicate voltage *opposite* in direction to zero.

Bearing this in mind, we can now get a clear mental picture of an alternating current. The current starts out at zero and gradually increases to a maximum. The current then reverses and gradually drops

LEARN TO FLY!

EXPERIENCE + KNOWLEDGE = SAFETY

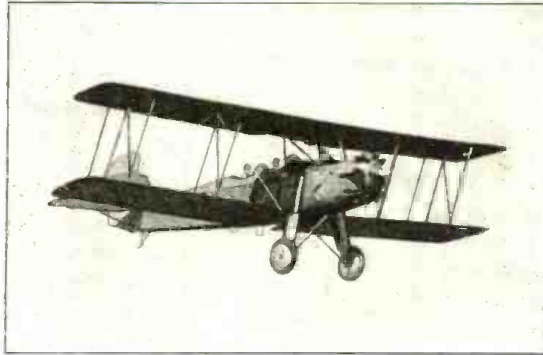

SAFAIR

INSTRUCTORS All over 15 years experience.

AIRPLANES Land & Sea. Best obtainable for training and safety.

INSTRUMENT Flying instruction with us has enabled some of our graduates to FLY the Atlantic.

GROUND SCHOOL New sessions start at New York University 15th day of each month.

SAFAIR FLYING SCHOOL

New York Office
240 MADISON AVE.
Ashland 4-5107

Hangar "B"
ROOSEVELT FIELD
Garden City 960

U. S. GOVERNMENT APPROVED SCHOOL

Formulas and Recipes FOR THE PRACTICAL MAN

CONTENTS OF BOOK

1. Adhesives: Glues, Cements, Gums, Mucilages, Lubricants. 2. Cleansing: Stain Removers, Paint Removers, Bleaches, Cleaning Fluids. 3. Metal Craft: Coloring, Oxidizing, Plating, Repairing, Welding, Polishes, Alloys, Solders, Amalgams. 4. Paints: Colors, Stains, Varnishes, Enamels, Luminous Paint, Washable Paint; Paint-Removing, Waterproofing, Fireproofing. 5. Glass-Working: Cutting, Drilling, Boring, Bending, Blowing, Etching, Engraving, Frosting, Silvering, etc. 6. Wood-craft: Fillers, Fireproofing, Acid-proofing, Waterproofing; Furniture Polishes, Finishes, etc. 7. Inks: Recipes, Eradicators, Ink Stain Removers; Special Inks; Colored, Indelible Sympathetic, Invisible, Hectograph. 8. Photography: Developers, Emulsions, Fixers, Sensitizing, Toning, Printing, Photographic Paper, Blueprint Paper. 9. Antidotes for Poisons, Remedies for Burns and Scalds, Disinfectants, First-Aid in Accidents, Emergency Remedies, Home Remedies. 10. Preparation, Manipulation, Handling, Mixing, Measuring, Weighing, Filtering, Straining Solutions; List of Technical Substances; Emulsifying; Use of Hydrometer, Use of Thermometer; Tables of Weights and Measures, Decimal System, Useful Tables.

PRICE 50c Postpaid

Send stamps, cash, check or Money Order

TECHNIFAX

Division RT-1138

558 W. WASHINGTON BLVD. CHICAGO, ILL.

to zero. But instead of stopping at zero, the current continues and builds up to a maximum and then returns again to zero. The alternating current is then said to have gone through *one cycle*. Figure 4 gives a graphic picture of an alternating current.

Figure 4 shows how an alternating current starts out at zero, rises to maximum amplitude, drops back to zero and turns about doing the very same thing in the opposite direction. We have called this the *cycle* of an alternating current, and the number of these cycles that occur in one second is known as the *frequency*. We have both high and low frequency electric currents. Some may have cycles of only sixty per second (such as our ordinary house current) while others may have cycles of hundreds of thousands per second.

Next lesson will cover voltage, amperage, resistance, Ohm's law, generation of current, transformer action, etc.

DATAPRINTS

Only 33 $\frac{1}{3}$ c each
in orders of 3 at 81

BUILD YOUR OWN—SAVE MONEY!

RADIO CONTROL FOR MODEL BOATS, PLANES, ETC.



Circuit data50c

20 ELECTRIC LODGE & PARTY TRICKS. Fun Galore!

"How to Do 'Em" Data 50c



S-W DIATHERMY (Artificial Fever)

Dataprint giving Constructional data for Small, Medium and Large size App. (AH 3)....50c

Induction PIPE & ORE LOCATOR

Construction Data.....50c

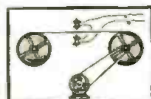

RECORD VOICE OR CODE on Steel Wire!

Telegraph Data, for Voice or Code.....50c

TESLA COIL DATA:

Data print—drawings and data for building 30-inch spark Tesla.....50c
Exciter—1 K.W. 20,000 Vt. Transf. 50c
3" Spk. Tesla Coil. Works on Ford Coil.....50c
3" Spk. Oudin Coil. Works on 110 A.C.50c
20 "Triets" with Teslas & Oudins.....50c
8" Spk. Tesla Coil.....50c
Exciter—1/4 K.W. 15,000 Volt Transf.50c
Violetta—1" Spk. Oudin. Vib. type.....50c
How to Operate Oudins from V. T. Osc.50c



More DATAPRINTS You Need!

Water Turbines "Rewinding" Armatures
Water Wheels Induction Balance
100 Mechanical Movements Tautograph
Motor Circuits (20) Einthoven String Galvanometer
Telephone Hookups (20) Magnets and Solenoids—Get list before ordering.
Polarized Relay. Ultra-sensitive
Ring 4 bells on 2 wires Wreathstone Bridge
30 Simple Bell Hook-ups Induction Coils—1 to 12 inch Spk data
Electric Chime Rinker type Electric Pipe Thawer
Welding Trf. 2 K.W. 110 V. Prim. 18 V. Sec.... 50c
5 prints \$1.50 or 10 for \$2.00; single prints 50c

The DATAPRINT Co.

Lock Box 322

RAMSEY, N. J.

All about the
SHORT WAVE LEAGUE

A FEW WORDS AS TO THE PURPOSE OF THE LEAGUE

The **SHORT WAVE LEAGUE** was founded in 1930. Honorary Directors are as follows:

Dr. Lee de Forest, John L. Reinartz, D. E. Replogle, Hollis Baird, E. T. Somerset, Baron Manfred von Ardenne, Hugo Gernsback, Executive Secretary.

The **SHORT WAVE LEAGUE** is a scientific membership organization for the promotion of the short wave art. There are no dues, no fees, no initiations, in connection with the **LEAGUE**. No one makes any money from it; no one derives any salary. The only income which the **LEAGUE** has is from its short wave essentials. A pamphlet setting forth the **LEAGUE'S** numerous aspirations and purposes will be sent to anyone on receipt of a 3c stamp to cover postage.

FREE MEMBERSHIP CERTIFICATE

As soon as you are enrolled as a member, a beautiful certificate with the **LEAGUE'S** seal will be sent to you, provided 10c in stamps or coin is sent for mailing charges.

Members are entitled to preferential discounts when buying radio merchandise from numerous firms who have agreed to allow lower prices to all **SHORT WAVE LEAGUE** members.

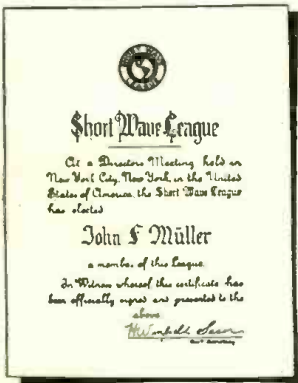

If you wish your name engraved on the Free membership certificate, as illustrated above, please send 25c to cover cost.

SHORT WAVE ESSENTIALS LISTED IN OPPOSITE COLUMN SOLD ONLY TO SHORT WAVE LEAGUE MEMBERS

They cannot be bought by anyone unless he has already enrolled as one of the members of the **SHORT WAVE LEAGUE** or signs the blank below (which automatically enrolls him as a member, always provided that he is a short wave experimenter, a short wave fan, radio engineer, radio student, etc.).

Inasmuch as the **LEAGUE** is international, it makes no difference whether you are a citizen of the United States or any other country. The **LEAGUE** is open to all.

**Application for Membership
SHORT WAVE LEAGUE**

SHORT WAVE LEAGUE 11-38
99-101 Hudson Street, New York, N. Y.

I, the undersigned, herewith desire to apply for membership in the **SHORT WAVE LEAGUE**. In joining the **LEAGUE** I understand that I am not assessed for membership and that there are no dues and no fees of any kind. I pledge myself to abide by all the rules and regulations of the **SHORT WAVE LEAGUE**, which rules you are to send to me on receipt of this application.

I consider myself belonging to the following class (put an X in correct space): Short Wave Experimenter Short Wave Fan Radio Engineer Student

I own the following radio equipment:

Transmitting

Call Letters

Receiving

Name

Address

City and State

Country

I enclose 10c for postage and handling for my Membership Certificate.

The Short Wave League

(Continued from page 404)

Len Carling—Observer for Illinois

Call	Freq.	R	S	Call	Freq.	R	S
CT1AY	14.030	5	7	LA1F	14.260	4	5
CT1PR	14.260	5	7	LU7BK	14.095	5	8
CX1AA	14.020	5	7	OA4C	14.050	5	9
EA9AH	14.005	5	8	ON4BG	14.145	4	7
FA3HC	14.140	4	6	ON4NW	14.135	4	7
F8UE	14.270	4	7	PA0WN	14.265	5	7
G2GF	14.030	4	6	PY1DW	14.010	5	8
G2MF	14.030	5	8	PY1FR	14.050	5	8
G2TR	14.110	5	7	PY1GO	14.060	4	5
G3PS	14.070	5	7	PY2CK	14.090	5	7
G5PJ	14.120	5	7	PY2DA	14.000	5	7
G5JO	14.085	5	7	PY2KP	14.290	4	5
G5MO	14.105	5	9	PY4CT	14.050	5	6
G5TP	14.060	5	7	PY5AQ	14.115	5	7
G6AG	14.060	4	6	PY8AD	14.315	5	7
G6DL	14.020	5	7	PK6XX	14.020	5	8
G6GF	14.110	5	8	VP1DM	14.080	5	6
G6HV	14.270	5	8	VP3AA	14. . .	5	7
G6QS	14.095	5	8	VP6FO	14.100	4	7
G6WU	14. . .	5	8	VK2NS	14.015	5	8
G8CL	14.335	5	7	K4JP	14.020	5	7
G8UR	14.130	5	7	XE1BV	14. . .	5	9+
GM2UU	14.276	5	7	XE1CQ	14.030	5	8
GM6RG	14.260	5	8	XE1GE	14.260	5	8
HC1JW	14.020	5	8	XE1Q	14.265	5	8
HH2PB	14.325	3	6	XE3AQ	14.035	5	8
HR2A	14. . .	3	6	YV1AQ	14.005	5	7
KA1ZL	14.250	4	6	TI3AV	14.135	5	9
K4ENT	14.240	5	8	G8OG	14.045	5	8

Flat-Top Beam Antenna

(Continued from page 440)

Very peculiar results can be obtained with an *improperly adjusted* beam antenna. This often results from the *entire antenna and feeders picking up the signal!* This is the condition desired when the antenna is used with the feeders in parallel at the coupler, but may also be present to some extent when the *broadside* response is desired. Unbalance in the feed line or coupler or capacitance coupling of the coupler coil to the receiver may be causes of this effect. Grounding the center of the coupler coil may assist in reducing this.

Operation on Other Frequencies—7, 28, and 56 mc.

By making the dimensions of the flat-tops of Figure 1 one-half or *one-quarter* the size shown, the antennas may be used for reception of amateurs in the 28 or 56 mc. bands, respectively. In the same manner as for 14 mc. operation, the *series tuned* coupler is used with feeders which are somewhat more than an odd number of quarter wavelengths long, and the *parallel tuned* coupler with feeders somewhat more than an even number of quarter wavelengths long.

However, by retuning the coupler unit, the antennas with the dimensions given in Figure 1 may be used over a wide range of frequencies. In fact, if sufficient turns are added to the coupler coil, the antennas may be used on 7 mc. The center-fed flat-top of Figure 1-B is more suitable for use on this frequency than is the end-fed. A change from one type of coupler to the other may also be required, that is, from parallel to series tuning or vice versa. Also by reducing the number of turns of the coupler coil, the antennas with the dimensions given in Figure 1 can be operated up to frequencies of 28 mc. and higher. A change of type of coupler may also be required. On 28 mc. the maximum response under these conditions will not be *broadside* but rather in *four directions*, making angles of about 45 degrees with the antenna.

Height

For long-distance reception on 14 mc. a flat-top height above ground of 40 to 50 feet or more is helpful, but less height, such as 25 or 30 feet, should be quite satisfactory.

Accessories for Members of the
SHORT WAVE LEAGUE

Every member of the **SHORT WAVE LEAGUE** wants to identify himself in some way. For your convenience the League directors have prepared suitable letterheads, label buttons, stickers, etc. In addition there are many short-wave accessories, such as maps, globes, etc., which the League offers only to members at special prices. Take your choice from this advertisement. **THESE ESSENTIALS ARE SOLD ONLY TO LEAGUE MEMBERS.**



LEAGUE LETTERHEADS

A beautiful, official letterhead has been designed for members' correspondence. The letterhead is invaluable when it becomes necessary to deal with the radio industry, mail order houses and radio manufacturers, as many houses offer members of the **LEAGUE** preferential discount. The letterhead is also absolutely essential when writing for verification in radio stations either here or abroad. It automatically gives you a professional standing.

A—SHORT WAVE LEAGUE letterheads. 50c per 100

A—50c per 100

WORLD GLOBE

This important essential is an ornament for every den or study. It is a globe, 6 in. in diameter, printed in fifteen colors. Mounted in such a way that it can be washed. This globe helps you to intelligently log foreign stations. The base is of solid walnut, and the semi-meridian of a nickel-like metal. Entire device substantially made, and will give an attractive appearance to every station, emphasizing the long-distance work of the operator.



D—Globe of the World 89c

D—89c each

SHORT WAVE MAP OF THE WORLD

This beautiful map, measuring 18x28 in. and printed in 18 colors, is indispensable when hung, in sight or placed "under the glass" on the table or wall of the short wave enthusiast. It contains a wealth of information such as distances to all parts of the world, political nature of the country in which a broadcast station is located, and from the manner in which the map is blocked off gives the time in different parts of the world at a glance.



F—SHORT WAVE Map of the World. 25c

WORLD RADIO MAP AND STATION FINDER

The finest device of its kind published. The world's map on heavy board is divided into 23 sections, while the rotary disc shows you immediately the exact time in any foreign country; invaluable in logging foreign stations. Also gives call letters assigned to all nations. Size 11"x22".

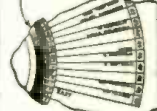

C—Radio Map of the World and Station Finder. 25c

Prepaid

LEAGUE LABEL BUTTON



E—35c each

This beautiful button is made in hard enamel in four colors, red, white, blue and gold. It measures three quarters of an inch in diameter. By wearing this button, other members will recognize you and it will give you a professional air. Made in bronze, gold filled, not plated. Must be seen to be appreciated.

E—SHORT WAVE LEAGUE label button 35c

Prepaid
EE—SHORT WAVE LEAGUE label button, like the one described above, but in solid gold. \$2.00

Prepaid

SHORT WAVE LEAGUE

99-101 Hudson St., New York, N. Y.

SHORT WAVE LEAGUE 11-38
99-101 Hudson Street, New York, N. Y.

Gentlemen:

I am a member of the **SHORT WAVE LEAGUE**
 Please send me application for membership in the **SHORT WAVE LEAGUE**

Please send me the following short wave essentials as listed in this advertisement:

.....

for which I enclose \$..... herewith.

Name

Address

City and State

Country

(The **LEAGUE** accepts money order, cash or new U.S. Stamps in any denomination. Register cash and stamps.)

"Garden of Eden"

(Continued from page 391)

dreams became actualities. A single transmitter was constructed, operating in the 1.7 mc. and 3.5 mc. bands. One thousand watts were fed down the hungry throats of two 204A tubes in the final, class C amplifier. A companion modulator, ending in four 204A's in parallel, impressed speech onto the carrier. The results clearly brought to light a fact that is now well known: amateur transmitters could be the equals of their broadcast station brothers. Mr. Gasset (W8CRM); his assistants George Meyers (W8NXX), and Whittier Clark (W8IHN), continued to enlarge and improve the station, with the firm support of the Edison Institute. Today the station, in its picturesque setting, is truly the *Ham's Garden of Eden!*

Located in Dearborn, Michigan, a suburb of Detroit, this "shack" is the gathering place for hams from all parts of the globe. The station proper, nestling in the shadow of one of the huge antenna towers, is divided into two main portions: the *studio and transmitter room.*

The *voice-level* is read from a meter on the control panel, the decibel indicator being located at the operator's left hand. A Super Pro receiver takes care of the incoming signals, as far as the frequencies extending from ten meters to one hundred and sixty meters are concerned. Special equipment is available for the *ultra high* frequencies. Serving as a more or less control and advice station to nearby stations, W8NQS is equipped with a 100 kc. crystal channel marker and monitor. For its own use, and as a welcome help to fellow amateurs, a two-inch cathode ray oscilloscope has been installed and is in constant use.

A panel check door leads from the studio to the transmitter room. Here are housed the three active transmitters (others in process of construction) which permit operation in all bands, plus the added beauty of variable power input up to the legal limit of one thousand watts. In a separate rack, conforming to the best practice, is the universal power supply, floor trench cable leads supplying all units with correct power levels. Phone transmission is used in all bands except the forty meter cw. channel. Of course crystal control is used throughout, the five and ten meter bands included. Each transmitter is a splendid example of radio engineering. No stage is over-driven, yet by careful design, the efficiency of the unit, as a whole, is kept very high. An interesting highlight is the physical arrangement of each stage. The designer, keeping in mind the educational aims of the Edison Institute, has not only created an efficient piece of scientific apparatus, but also made it possible for students of radio to easily follow each circuit by an ingenious placement of parts and wiring.

SHORT WAVE CRAFT, by means of timely articles on ultra high frequency transmitters and receivers, has stressed the fact that the five meter band will never take its place among its older brothers, until we amateurs utilize its vast resources with good equipment. Along these same lines, W8NQS has been doing more than its share in eliminating unstable rigs, "hand hogs," loop modulated oscillators, etc., by permitting fellow hams to really see and hear what an up-to-date signal, produced with modern methods, can do in this band. How well they have succeeded can be seen in the fact that fully 80 per cent of the stations now operating on this wavelength, in the city and suburban area about W8NQS, are radiating signals that can be tuned in on a receiver of ten kilocycles selectivity and will "stay put."

RADIO'S MANY NEW BOOKS HAVE BEEN ADDED TO MOST COMPLETE LOW-PRICED TECHNICAL LIBRARY



THE RADIO-CRAFT LIBRARY SERIES (each volume fifty cents)—a most complete and authentic set of Volumes—treats individually, important divisions of radio, refrigeration and air conditioning. Each book has been designed to give you the opportunity to learn one or more branches of the fields mentioned. The authors of the books are well-known to everyone. Each is an expert—an authority on the subject—each is thoroughly familiar with the field which he represents.

ALL BOOKS ARE UNIFORM—The volumes in the RADIO-CRAFT LIBRARY SERIES measure 6 x 9 inches. Each book contains on an average of 50 to 120 illustrations. The books are printed on an excellent grade of paper which makes the type easy reading.

Here Are the Titles - - -

- | | | |
|--|---|--|
| No. 2. MODERN VACUUM TUBES | No. 12. PUBLIC ADDRESS INSTALLATION AND SERVICE | No. 17. SERVICING WITH SET ANALYZERS |
| No. 3. THE SUPER-HETERODYNE BOOK | No. 13. ABC OF AIR CONDITIONING | No. 18. POINT-TO-POINT RESISTANCE ANALYSIS |
| No. 6. BRINGING ELECTRIC SETS UP-TO-DATE | No. 14. POCKET RADIO GUIDE | No. 20. THE CATHODE-RAY OSCILLOSCOPE |
| No. 9. AUTOMOBILE RADIO AND SERVICING | No. 15. ABC OF REFRIGERATION | No. 21. BREAKING INTO RADIO SERVICING |
| No. 10. HOME RECORDING AND ALL ABOUT IT | No. 16. PRACTICAL RADIO CIRCUITS | |

RADIO PUBLICATIONS • R&T 11-38 • 99T Hudson Street, • New York, N. Y.

I have circled below the numbers of books in the RADIO-CRAFT LIBRARY SERIES which you are to send me. I have included my remittance in full, at the price only 50c each. (Stamps, checks or money orders accepted).

2 3 6 9 10 12 13 14 15 16 17 18 20 21

Name Address

City State

All books are sent postage prepaid

Just Published . . . a NEW RADIO AND ELECTRONIC DICTIONARY Containing 3,800 Definitions

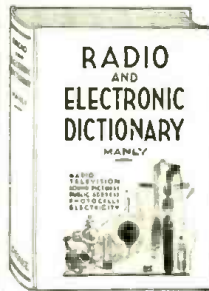

THIS RADIO AND ELECTRONIC DICTIONARY, written by Harold P. Manly, explains the meaning of 3,800 words used in radio, electronics and other closely allied fields. It includes new terms used in radio transmission, sound pictures, television, public address, aviation radio, navigation and industrial control, photo-electricity, photocell application, telephotography, etc. This dictionary permits learning every new expression whether you hear it or read it. Alphabetically arranged for quick reference. 550 illustrations augment definitions in the text.

The book is recommended for students, instructors, engineers, service men, experimenters, salesmen and everyone in any way associated with radio. **ONLY IN U. S. A. POSTPAID Price \$2.50**

BOOK OF ITS KIND—HANDY—EASY TO USE—AND TIMELY. The RADIO AND ELECTRONIC DICTIONARY is new, authentic and printed in a single volume of 300 pages, 6 1/2 x 9 inches. The book weighs two pounds and bound in durable cloth. **SHIPPED ANYWHERE \$2.50 IN U. S. A. POSTPAID Price \$2.50**

Mail remittance by check or money order to
RADIO PUBLICATIONS
99 HUDSON STREET NEW YORK, N. Y.

New Crystal Catalog

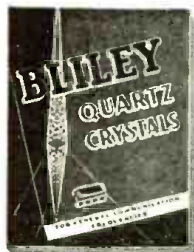

• **RADIO** engineers dealing with frequency control of transmitters, receivers, monitors, test equipment, or similar apparatus will be interested in the new Bliley Catalog now being distributed. Precision quartz crystals and mountings for all frequencies from 20 kc. to 30 mc. are listed and fully described. A quick reference table gives immediate information regarding the type of crystal, the type of holder available, etc. Catalog G-10 lists only "commercial" crystals—not "Ham" crystals.

Of special interest are the high frequency crystal units, types MO2 and MO3, for frequencies from 7.5 mc. to 30 mc. Designed to provide greater stability and reliability under severe physical operating conditions, these new units are particularly adapted for mobile and portable applications. They are especially recommended for use in ultra-high frequency police equipment.

Copies of catalog G-10 (Hams should ask for Circular A6, not G-10) can be obtained from the Service Dept., RADIO & TELEVISION, 99 Hudson St., New York City.

WESTINGHOUSE UNIVERSAL MOTOR

\$2.55 110 Volts AC and DC
Shipping Weight 3 lbs.

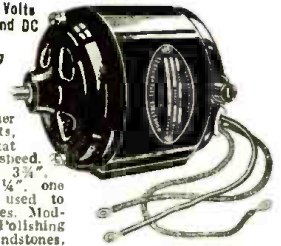

Specifications: 1/30 H.P. operates on either A.C. or D.C. 110 volts, 5000 R.P.M. Rheostat can be used to vary speed. Height 3 1/4", Length 3 3/4", Width 1 3/4". Shaft 1/4", one inch long. Can be used to drive Sewing Machines, Models, Buffing Lathes, Polishing Head, Drills, Grindstones, etc., etc.

- MOTOR only \$2.55
MOTOR with Arbor and 1/4" Chuck \$3.55
Add 25c for special packing and mailing anywhere in U. S. A.

MICROPHONE and RECEIVER

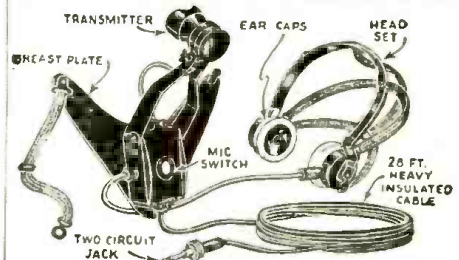

THIS Microphone and telephone headset outfit was built especially for the U. S. Navy Aviation Corps. The Holtzer-Cabot Electric Company constructed the outfit to Government specifications. The outfit consists of a low-impedance carbon microphone (transmitter), securely fastened to a metal breast-plate, and a set of heavy-duty, low-impedance earphones. A specially constructed switch on the back of the breast-plate controls the microphone circuit. The earphones are U.S.N. Utah type, attached to adjustable headband. Twenty-eight feet of very heavy weather and waterproof conductor cable is furnished. Current of not more than 10 volts should be used. A storage battery is the most satisfactory current supply. **U. S. Navy Airplane-type Microphone and Receiver as described \$4.96**
Shipping weight—9 lbs.

We will forward Shipments by Express Collect if sufficient postage is not included.

WELLWORTH TRADING COMPANY
560 W. Washington Blvd., Dept. RT-1138, Chicago, Ill.

Have you bought your copy of the **RADIO AMATEUR COURSE?**
See the Inside Front Cover.

COMMERCIAL NOTICES 10¢ A WORD

Under this heading only advertisements of a commercial nature are accepted. Remittance of 10c per word should accompany all orders. Copy should reach us not later than the 10th of the month for the second following month's issue.

AGENTS WANTED

300% PROFIT SELLING GOLD
Leaf Letters for Store Windows; Free samples. Metallic Co., 446 North Clark, Chicago.

CORRESPONDENCE COURSES

500,000 USED CORRESPONDENCE
Courses and Educational Books. Sold. Itented. Exchanged. All subjects. Satisfaction guaranteed. Cash paid for used courses. Complete details and bargain catalog free. Send name. Nelson Company, 3486 Manhattan Building, Chicago.

INSTRUCTION

RADIO ENGINEERING, BROADCASTING, aviation and police radio, servicing, marine and Morse telegraphy taught thoroughly. All expenses low. Catalog free. Dodge's Institute, Colt St., Valparaiso, Ind.

AMATEUR RADIO LICENSES
home study course in code and theory. Reasonable. Efficient and thorough. Results guaranteed. American Radio Institute, 200 Broadway, New York, N. Y.

MISCELLANEOUS

3/4 INCH TR. 0-125 VT. A.C.
Voltmeter. 0-10 A.C. Ammeter. \$2.75 each. Weston D.C. 0-7 and 0-140 Voltmeter. 2 1/2" x 9". D.P. Switch \$2.75. Nat'l. MEBT-4 SLE. T.R.F. chassis and Thord. 45 P.P. Pack. \$7.50. 10" MUTER DYN. SPKR. \$3.00 Victor 72" Hi-Fi Orthophonic Horn.

Mag. and Acoustic Pick-ups, \$10.00. Plus express. \$400.00 RCA battery Superhet—\$25.00. Harry Ackerson, Hamsey, N. J.

WE OFFER SUBJECT TO PRIOR
sale 7 m.m. lacquered cable used by the Government. It is an ideal cable for high voltage, low current service, such as used in radio transmitters, amplifiers, etc. It is a special steel wire, 20 gauge, with very heavy rubber insulation. Worth 12c a foot. Special price 50 ft. \$2.00, 100 ft. \$3.00. F.O.B. N. Y. Gold Shield Products, 350 Greenwich St., New York City.

PATENT ATTORNEYS

INVENTORS—PROTECT YOUR
rights before disclosing your invention to anyone. Form "Evidence of Conception"; "Schedule of Government and Attorneys' Fees" and instructions sent free. Lancaster, Allwine & Rommel, 436 Bowen Building, Washington, D. C.

QSL—CARDS—SWL

100 NEAT SWL CARDS PRINTED
with your name and address sent post-paid for \$1. Bunch of samples and WST Chart for five cents in stamps. WIFE, 16 Stockbridge Ave., Lowell, Mass.

RADIO EQUIPMENT

MUTER BARGAINS—WESTON
Model 506 DC Amperes 0-5, \$2.50; GE Type AO Amperes 0-30, \$2.50. WE Galvanometers. \$2.50. Set of 12 new Ward Leonard Vitreous Enamel Re-

lamps, 600-1000-2000 ohms, \$1.00. Miller Surplus, 2553 Madison, Chicago, Ill.

RADIOS

BARGAINS—5 TUBE NEW RADIO
complete with Dynamic Speaker \$5.95. 7 tube Superhet 12 1/2 to 35, 34 to 120, 180-550 meters \$14.95. Values cannot be duplicated. Fully guaranteed. H. G. Young, 127 Liberty St., New York.

SHORT WAVE DIATHERMY

RIG PROFITS FOR RADIO HAMS
selling short-wave diathermy apparatus and other electro-medical equipment to physicians. Old established firm. Exclusive territory. Intensive instruction course. McIntosh Electrical Corp., 223 N. California Ave., Chicago.

SHORT WAVE RECEIVERS

USED DOERLE'S D-38, BS-5, 7C,
reconditioned by factory, 40% off. See January Short Wave & Television for description. Kusterman, 68 Barclay St., New York.

SONG POEMS WANTED

WANTED ORIGINAL POEMS,
songs for immediate consideration. Send poems to Columbian Music Publishers, Ltd., Dept. K49, Toronto, Can.

TELEVISION

TELEVISION EQUIPMENT SINCE
1927. Arthur Fohl, 2123 Hubbard, Detroit, Mich.

RCA Parts Catalog

● UNDER the above title, the Radio Corporation of America has put out a new 16-page, 2-color, catalog featuring test instruments such as oscillographs, tube checkers, oscillators, bridges and modulators, output indicators and piezo-electric calibrators. A page is devoted to television parts; two pages to antennas; two more to phono pickups; another two to turntables and microphones; one to transmitters; and another to such accessories as "magic eye" kits, wave traps, etc.

This article prepared from data supplied by courtesy of Radio Corp. of America.

Television Kits in New Catalog



● THE 1939 Fall and Winter "Master" catalog No. 73, just issued by the Wholesale Radio Service Co., is said to contain more outstanding features than any of that company's previous catalogs. In the 188 pages is listed a line of Lafayette receivers, ranging from A.C.-D.C. midsets to multibute consoles. Also included are the latest sound systems, public address equipment, phonograph reproducing and recording equipment and a number of phono-radios. One section of the catalog has been devoted to new short-wave receivers and transmitters, and two perfected television kits for the experimenter are also described. Test equipment, accessories and parts for the service man and set-builder are also included, as is customary. In addition this catalog contains a camera section.

This article prepared from data supplied by courtesy of the Wholesale Radio Service Co.

Allied Radio Issues New 1939 Catalog

● A NEW 180-page catalog has just been released by the Allied Radio Corporation of Chicago. Thirty-two pages of this book are devoted to descriptions of the new 1939 line of Knight Radio Receivers, including all-wave, phono radios, midsets, etc., for A.C., A.C.-D.C. battery operation. There is also a large section devoted to service instruments, including the new Rider Chalmers and a new battery-operated tester for rural use. Another section features public address systems from 8 to 65 watts, in portable, mobile and permanent units, including school sound systems, intercommunicators and accessories. Other sections are devoted to recording equipment, recorders and play-backs, amateur transmitters and kits, Ham receivers and household appliances.

This article prepared from data supplied by courtesy of Allied Radio Corp.

School Issues Bulletin

● DODGE'S INSTITUTE has just released its 1938 Fall announcement which contains 16 pages of information on the outlook for employment, training for television, the value of skill, an argument in favor of Morse telegraph, letters from the school's graduates, and other interesting information. They have also published a 40-page booklet which outlines the subjects taught at the school, describes the faculty, the certificates which are issued, and so forth. Radio courses include broadcast engineering, marine radio operation, radio servicing, and a complete radio engineering course. The courses are described as very comprehensive, covering laboratory work, mathematics, announcing, D.C. and A.C. machinery, tubes, police and aviation radio, etc.

This article has been prepared from data supplied by courtesy of Dodge's Telegraph and Radio Institute.

FOR SALE (NON COMMERCIAL) 3¢ A WORD

Under this heading we accept advertisements only when goods are offered for sale without profit. Remittance of 3c per word should accompany all orders. Copy should reach us not later than the 10th of the month for the second following month's issue.

TWO IN ONE SHORT WAVE COIL
and super-selective crystal set plans. 15c each. Crystal set. \$3. Johnson, Box 816, Spokane, Wash.

SELL—110 V. 60 CYCLE FAN
belt drive, battery excited output 700W. D. Buck, 43 Hagen Ave., N. Tonawanda, N. Y.

SKY BUDDY, \$17.50. PATTERSON
PK-10, \$29.00, Ireting 12, \$39.00. Latest model SX-16 Super-Skylider, \$59.00. W9AIA, Butler, Missouri.

FOR SALE—HALLICRAFTER 1937
Sky Challenger, \$40, cost \$69.50. Covers 8 to 600 meters. Excellent condition. Complete 200 watt phone, T53 final, T230 modulators, Turntable, New 935 Acorn tube, \$2. WIFZX, 37 Oakland Street, Natick, Mass.

MOTOR GENERATOR, 1000 VOLT
DC, for use on 110-220 AC. Guaranteed good as new. Phone-CW transmitter, 100 watt panel type, full meter equipped. Original price \$650. Sell \$150. Tubes, insulators, transformers,

choke coils, condensers at reasonable prices. Write for price on MG or any items. Ensall, 411 Waverly, Warren, Ohio.

IM669 COMMUNICATIONS RECEIVER,
nearly new, for about half of new price. Gerst, 2674 W. 25th St., Cleveland, O.

FORCED TO SELL SKY-BUDDY,
\$17.00, 1521 Yale Ave., Salt Lake, Utah.

BARTER AND EXCHANGE - FREE!

NO ADVERTISEMENT TO EXCEED 35 WORDS, INCLUDING NAME AND ADDRESS

Space in this department is not sold. It is intended solely for the benefit of our readers, who wish to buy or exchange radios, parts, phonographs, books, magazines, etc. As we receive no money for these announcements, we cannot accept responsibility for any statements made by the readers. Use these columns freely. Only one advertisement can be copied should reach us not later than the 10th of the month for the second following month's issue.

accepted from any reader in any one issue. All dealings MUST be above board. Remember you are taking the U. S. mail in all these transactions and therefore you are bound by the U. S. Postal Laws. Describe anything you offer accurately and without exaggeration. Treat your fellow member the way you wish to be treated. We welcome suggestions that will help to make this department interesting and helpful to our readers.

TRADE PHONO-PLAYER 200
Watt Transmitter, buk, key, crystals, chimes, radio texts, meters, tubes for all wave R.F. and A.F. oscillators, microphones, record changer, recorder, 100 watt transmitter. C. Kowalaki, 1299 Kinsmoor, Fort Wayne, Indiana.

TRADE COMPLETE COLINS-
Hallicrafter phone station all bands; miscellaneous transmitting tubes and parts. Want National HRO or 7, meters and test equipment. W80QU, Wells-ville, N. Y.

TRADE 61.6 XTAL TRANSMITTER,
10 and 160 meter 50 watt phone transmitter, keying relay, 801, 860, 45's and other tubes, condensers, chokes, power transformers, etc. Write for list of parts. Want receiver or? W5HAE, 913 Jefferson, Jonesboro, Ark.

SWAP—GE—24/1500 VOLT DYNA-
motor; Bodine 110 volt DC to 110 volt AC motor generator set, 35mm motion picture projectors, radio parts; Want radio manuals, test equipment, 16mm sound projector, or? Wm. Hansen, Niles, Mich.

WANTED USED TEST EQUIP-
ment, also communication receiver such as Hallicrafter Sky Chief or Sky Challenger 11, will also exchange SWL cards with foreign countries, especially China or Africa. Carroll Anderson, 1666 Malasia Rd., Akron, Ohio.

HAVE UNIVEX 8 MM CAMERA,
projector, films. Would like Ham superhet or all wave super. Value new over \$40. Tom Cullen, 22 Simpson Ave., Wallingford, Conn.

WILL SWAP ELEN SW RECEIVER
or amateur model 7C-AB, 16 1/2 to 200 meters, including broadcast coil, Fry-Schick electric razor or photo supplies. Frank Seatos, 3476 N. Holton St., Milwaukee, Wis.

WILL SWAP NEW MICROSCOPE
with specimens in perfect condition, value \$10.00. Would like SW receiver, AC meters or code oscillator with key. Or what have you? Raymond Berube, 24 Hawley St., Lawrence, Mass.

WANTED 3 OR 4 TUBE SW
receiver, have some cash, back issues mags, tubes, parts, all letters answered. Whatsa? Robert Perlech, 3635 So. Wood St., Chicago, Ill.

HAVE \$1000 WORTH OF LATEST
commercial formulas, rare old sheet music published 60 years ago, fine sets of books, Want S.W. set, parts, books, magazines, printing supplies, typewriter, Henry Austin, 2608 Kirsch Ave., Alton, Ill.

SWAP REMINGTON 12 GA. AUTO,
shot gun, Western Field 20 ga. 3 shot hot action, large grease gun, electric clothes mangle, needs new heating unit. Want—radio, rabbit hound, Gus Spink, R.F.D. No. 50, Muskegon, Mich.

SWAP—SKY CHIEF RCVR.,
Oliver No. 9 typewriter, 1,000 stamps and album, 3 ft. telescope, almost anything in radio, want model airplane supplies or what have you. Write, William Briza, 405 N. Bradford St., Balto, Md.

TRADE FIVE TUBE A.C. T.R.F.
Receiver, Hammarlund coils and tuning condenser, Utah magnetic speaker, includes power supply. Want camera with f.6.3 lens, fairly fast shutter. Leigh F. Stifer, 924 Tuscarora Avenue, St. Paul, Minnesota.

TRADE: TWO LIONEL ELECTRIC
trains, coaches, plenty track switches. Also high power microscope, rack and pinion model. Would like model AF Argus, tube tester, or? J. Schuman, 1317 S. Newport, Tulsa, Okla.

WANTED TO BUY: A 465 K.C.,
plug-in coil kit with dual 140 var. cond. Must be in excellent condition. G. E. Ward, Jr., Willie Wharf, Va.

I HAVE RIDERS MANUAL NO.
2, Hickok, 0-1MA, 4 inch meter. Want small S.W. Rev. or parts for record player. Robert Cook, 421 West 5th Street, Marion, Indiana.

HAVE A 5 TUBE AC-DC, 75
meter up, also Win. 22 W.R.F. pump rifle. What have you? Clarence Cook, 920 Gwinn Street, Medina, N. Y.

HAVE SEVERAL NEW 50 WATT
tubes, exciter lamps, photoells and \$40.00 Philco short wave converter to trade for 8 mm or 16 mm films or equipment. S. F. Dittenderfer, 718 Sixth St., Lancaster, Pa.

SWAP, ONE G.E. 204A—250
watt. Good shape worth \$97.00 new, but will take any offer in trade. S. Andrewski, 11 Horatio St., Newark, N. J.

WANTED: CONDENSER TYPE
loudspeaker that came with Courier '65' or '1770' electrostatic model, need not be in working order. W. M. Walker, 19 Lobson St., Brighton, Mass.

ANY COMMUNICATIONS RECEIVER
wanted, 1 to 18 tubes, such as Hallicrafter, SWV, RME, etc. Also swap SWL cards. Maurice Wynne, 210 Hector, R.F.D. No. 3, New Orleans, U.S.A.

HAVE FOUNDATION KIT FOR
100 to 450 watt transmitter. Includes meters, condensers (var.) etc. Write for particulars. Want public address system or good camera (candle). Bill Sampson, Jr., 2208 Floyd, Richmond, Va.

(Continued on page 445)

Short Wave Listening Tips

(Continued from page 424)

rector General of Posts and Telegraph, Kaunas.

There appears to be a stranger on evenings close to or on 15.18 mc. but difficult to tune when GSO, Daventry, is on the air. Comes out more clearly after GSO leaves the air at 9 p.m. Lady and gentleman alternate in giving news in foreign language. Music also broadcast at times. USSR has RW96 on 15.18 mc. and follows this procedure in broadcasting news, but when on the air the program is not the same as USSR stations. Reports, please.

SOUTH AMERICA

Colombia is again changing frequencies. A late list gives the following changes:

Mc.	Call	Location	New Frequency (mc.)
9.63	HJ7ABD	Bucaramanga	4.815
9.616	HJ1ABP	Cartagena	4.805
9.52	HJ6ABH	Armenia	4.875
6.1051	HJ6ABB	Manizales	4.855
6.0857	HJ5ABD	Calí	4.825
6.013	HJ3ABX	Bogotá	4.795
4.9	HJ3ABH	Bogotá	4.895
4.88	HJ4ABP	Medellín	4.885
4.841	HJ3ABD	Bogotá	4.845
4.82	HJ7ABH	Bucaramanga	4.775
4.8	HJ1ABE	Cartagena	4.835
4.78	HJ1ABB	Barranquilla	4.785
4.66	HJ2ABJ	Santa Marta	4.865

The following stations are not included in the list and it is not known if they are to be changed to similar frequencies, if to leave the service, or remain as shown:

Mc.	Call	Location
9.51	HJU	Buenaventura
8.795	HKV	Bogotá
8.65	HJ4ABU	Medellín
6.145	HJ4AE	Medellín
6.070	HJ3ABF	Bogotá
6.054	HJ6ABR	Pereira
6.042	HJ1AHG	Barranquilla
6.	HJ1AHC	Quibío
4.79	HJ2AHC	Cúcuta
4.74	HJ6AHC	Ibagué

HJ4ABP, Medellín, and HJ2ABJ, Santa Marta, and HJ6ABH, Armenia, have already changed to the new frequencies and advised the writer accordingly.

HJ4ABU, 8.65 mc., has been transmitting for some time on this frequency. Station operated by Universidad de Antioquia Apartado Postal 217. Double folder veri card bearing picture of University on address side. Schedule 7 to 10 p.m. daily except Sunday.

HJ7ABB, 4.82 mc., Bucaramanga, Colombia, now probably on 4.775 mc., has been transmitting for several months and called Radio Santander. Its address is Apartado 37. Relays the programs of HJ7ABA on 1280 kc. Station transmits from 11:30 a.m. to 1 p.m. and 6 to 10:30 p.m. Programs are opened with the record "Serenade" and close with "Kiss Me Again." English after 10 p.m.

HJ3ABX, Bogotá, has been shifting frequencies from 6.013 to 5.99 mc.

HC2RL, 6.668 mc., Guayaquil, Ecuador, now sends programs on Sundays from 5:30 to 7:30 p.m. and Tuesday from 9 to 11 p.m.

HCODA, 9.4 mc., Guayaquil, Ecuador, is now sending out very attractive veri cards. Station called "La Voz de Alma."

HC2CW, Guayaquil, Ecuador, has changed frequency to 9.3 mc. according to late veri card received. Address, P.O. Box 1166.

HCJB, 8.831 and 4.107 mc., Quito, Ecuador, daily except Mondays. Also transmits religious programs on 6.23, 7.3, 12.46 and 14.42 mc. at various times. Station directed by Clarence W. Jones, a former Chicago resident who has many friends in the United States.

HC1PM, 5.725 mc., Quito, Ecuador, is still on the air, but with changed schedule. Now broadcasts on Mondays, 8 to 11 p.m.,

(Continued on following page)

BARTER and EXCHANGE FREE ADS (continued)

WILL SWAP HAWAIIAN TREMOLA valued at \$35.00 for good Sky Buddy or similar receiver or P. A. equipment. E. H. Wilson, P. O. Box 62, Mill Creek, W. Va.

WESTON 337 SET TESTER WITH meters, not wired, four model pin game, jigsaw, magnetic pickup, 2 small microphones, Jewell 0 to 6 v. D.C. Voltmeter, power supply, need Instructograph with tapes, Douglas Phelps, Sidney, N. Y.

TRADE OFFICIAL BOY SCOUT canteen, Lee tennis racket, Brownscope, triple objective microscope, articles in excellent condition, for used Astatic D-104 mike or what have you? Write Dan Owen, 1303 E. McDaniel, Springfield, Missouri.

WANTED: GOOD ROLL FILM camera, about F.4.5, 1/300 second shutter. Have 22 rifle, new 1/10 second stop watch warranted perfect condition. 50X-150X microscope "Jena." Also cash. Make offer. Walter Turner, 2 Washington Ave., New Rochelle, N. Y.

SWAP-6V SPEAKERS, NEW and used parts. GST. Radio, Itatio Engineering, Projection Engineering, tubes, SW converter, B Eliminator. Want RR proceedings, Univex, D. Buck, 43 Hazen Ave., N. Tonawanda, N. Y.

5 METER: WANTED GOOD FIVE meter transmitter as well as 5 meter super. Please write and give me details. Also will trade QSLs, SWLs. Calvin Moreland, 1011 Willowbrook, Compton, Calif.

SWAP: JIMMY DE FOREST BOXING course, National condensers, dial, Model 5 (Philco) radio, 100 radio mags; five pairs pones. Want oscilator or auto course or? V. Pavlet, 17 1/2 Austin St., Cambridge, Mass.

WILL TRADE ELECTRIC PHONOGRAPH motor, turntable, pickup, new and used radio parts. Just name it. I've got it. T. E. Caudill, 1535 E. Florida St., Springfield, Mo.

EASTMAN AUTO FOCUS ENLARGER in perfect condition complete, value twenty dollars. To trade for 5" x 7" view camera. Send negative for free sample of work made on it. Hoyt Reischling, 813 N. Alamo, San Antonio, Texas.

WANT SW SET! SWAP GHIRARDI Field Service Data B., telescope, key, phones, helmet, aviation engine, test B., 21 radio mags., 26 Chap. Science B.M. ship making B. Total value \$10-30. Robert L. Blinard, 206 Prospect Park W., Brooklyn, N. Y.

WANTED: JOWETT INSTITUTE of Physical Culture course complete with patented progressive dumbbells; books and courses by Professor Deshaunet, Eugene Sandow, Alan Calvert, for J. L. Nilsen, 290-a, Mt. Prospect Avenue, Newark, New Jersey.

HAVE 25 WATT 6LG CRYSTAL xmitter, complete with crystal and meter, covers all bands. Want 2 or 3 tube short-wave superhet or TRF receiver or what have you. Victor Samardza, 1044 Longfellow Ave., Bronx, N. Y. U. S. A.

HAVE A 1-TUBE ALL WAVE SET tuning from 25 to 550 meters without plug-in coils. Will trade for? W. R. Cunningham, R.R. 10, Box 123, Indianapolis, Ind.

STAMPS, ALL KINDS, ALL countries, French cols., Luxembourg sets, British cols. Send me your swap, preferably stamps or I. Baird, 1125 Graniteville, Vanover, B. C.

HAVE PERFECT DIAMOND mounted ladies ring white gold \$239. Will trade for 300 or 400 watt phone xmit or late model communications receiver. Give full particulars in writing. WSGKR, McGregor, Texas.

I HAVE A GOOD B-ELIMINATOR, a 50 mfd. midjet variable condenser, and a 30 and 58 tube. I would like to swap for a good short wave receiver. Lowell Melton, Hill, Illinois.

WILL TRADE COMPLETE VIBRATOR power pack, including tube and 6 volt Bala speaker. Would like stamp collection or good mixture. Elmer Swanson, 10 Depot Sq., Englewood, N. J.

WILL TRADE MEN'S FULL SIZE bowling ball for what have you. F. Vieweger, 1411 S. 17th St., Manitowoc, Wis.

WILL TRADE BAKED COPIES S.W.&P., Radio-Craft, radio books in very good condition. Would like radio equipment for a beginner. Will answer all letters. Oakley Kerelum, CCC Cp. S-229, McCall, Idaho.

TRADE 35 MM ZEISS MOVIE Kinamo, 3-80 foot magazines F.7 lens, spring motor and case for DeVry 35 movie or late model amateur outfit. W. McInnis, 30 E. Laguna, Tucson, Arizona.

WILL SWAP A CANDID CAMERA (Olympic) 4.5 lens, 1/300 shutter, 1/1000 flash 616 or 620 folding camera with bellows and with F.8.3 or F.7 lens. Morris M. Rosen, W2KNP, 562 West 144 Street, New York City, N. Y.

WANTED: SKY-BUDDY RECEIVER. Will trade a used \$10 drafting kit, 20 copies of S.W.&T., Baby Brownie camera, test earphones, 600, 37, 57, 62, tubes and some cash, radio parts. Join laneski, 614 Cortland St., Perth Amboy, N. J.

SWAP-NEW PARTS AND TUBES, Aerovox condensers and resistors, RCA oscilloscope, Gernsback manuals, quality test equipment, for ham parts or will consider any swap offer. Leaf Klinton, 1440 Caledonia St., LaCrosse, Wis.

STEWART WARNER 6 TUBE battery set, 2 tube 56 meg x'ceiver, collectors stamps, 1 tube 13 meter to broadcast set. Exchange for 2 or 3 tube sw set, collector radio matter. Hartman, 5713 5th Ave., Brooklyn, N. Y.

WANTED: ONE "BUG" TELEGRAPH key which must be in good condition. Will make an offer in way of a specialized stamp collection. All inquiries welcomed. WILLAC, 30 East Sixth St., Pottstown, Penna.

5 LB. COIL 31 ENAMEL WIRE, filament trans. with two 5 volts at 6 amps windings, 5 phono records for cast practice, electric clock. Want xmit tubes, condensers or? Newell Key, 208 Congress St., East Mead, Keesport, Pa.

SWAP NATIONAL SW-45 TRF, six tubes, seven sets coils, National power supply, speaker. Also Jewell meters, 1100 volt 400 mil transformer, HV tank condensers for photographic equipment, enlarger, communications receiver, Verion Eswar, R. No. 3, Independence, Mo.

WILL SWAP 2 1/2-5 METER TRANSCEIVER, set analyzer, 5 meter transmitter, receiver for good S.W. receiver or? Bud Carson, 1618 W. Second St., Dayton, Ohio.

HAVE COLLECTION 125 DIFFERENT cartridges; parts for two tube short wave receiver, including tubes, 4 Meissner coils, Trade for firearms, old coins, old glass, carved ivory, Hallcrafters type SM18 'S' meter, Frank Wheeler, Osborne, Kansas.

TRADE MODERN BUSINESS AND commercial law 6 volumes, National business success course, World atlas, 3 lower field glasses, 7 jewel Elgin wrist watch, for communications receiver. All letters answered. Clinton Keay, Marselles, Ill.

SWAP, SHAGG PHOTOS AND SWL cards, especially photos, also swap mint stamps. Anywhere in the world, 100% QSL, Cecil J. Howard, 219 Ellena Street, Maryborough, Queensland, Australia.

SWAP: ONE FISHING REEL FOR 2 parts and books, Write for information. QRA, B. C. Murray, Box 116, Hilo, New York.

HAVE CW TRANSMITTER AND power supply, 3 shile rules, 1 electric clothes pressers. Want Peak preselector, kool candle camera, or what have you? Fred A. Cook, Dutch Neck, N. J.

SWAP ELGIN III, 5 METER transceiver, Univex 8 mm movie camera, Falcon senior camera, handset for Halifafter, RCA, Itaco or similar type. Write for further details. Joe Thomas, 318 So. 10 St., Quincy, Ill.

WILL SWAP LATEST FORAULAS, business plans, courses, stamp and sportsman's magazines for late radio course, textbooks and magazines, automatic code sender, key, meters, any SW sets or parts, A. Windsor, 1004 State, Alton, Ill.

WANTED: GOOD USED R.M.E. DR20 preselector, 110V-60 cycle and battery operation. Have Weston exposure meter, Kalart synco-flash, Willow Printer, like new. Value \$51.00. Bert Kavalaugh, 516 West 136th St., N.Y.C., N.Y.

DAYRAD TUBE CHECKER, Weston 1.5-150 volts D.C. voltmeter, 300 v. power pack, 12 in. dynamic speaker, radio parts, etc. to trade for SW-3, Sky Buddy or similar sw receivers or? Billy Epps, Mincola, Tex.

WANTED 5-10 METER FACTORY made receiver. Have Carter kenemotor with filter, 6V, 4 1/2 A, input 250V, 50 ma output, in good shape. To trade for same. W. Fuller, 709 Fenton St., Lansing, Mich.

TRADE—TRUMPET WORTH \$30.00 for sw receiver (5 or more tubes). Have magazines (1925 to date), broadcast parts. Trade for sw parts or what have you? Edward W. Farps, 1316 E. Babo St., Pensacola, Fla.

WANTED: CLASSICAL SWING phonograph records, record player, amplifier, music magazines, in good condition. Give for one good 35 record ten 35c slightly used records. Have other items also. Joseph Monahan, Old Frankfort Pike, Lexington, Kentucky.

RTA RADIO COURSE, EXCELLENT condition, high grade, authentic, and around hundred dollars, also Cook's electricians course, electricity in general. Will allow radio, testing equipment, fast camera, small engine, or what. Glenn Watt, Chanute, Kans.

TRADE COLLECTION OF STAMPS valued at \$149.00 by Scott, mtd. in Scott's Ill. Junior album. want A.C. S.W. receiver 3-550 meters in good condition. Frank Low, Napanoch, N. Y.

WANT: USED TELETYPE OR Instructograph, with tapes, good working order. Will trade or pay cash. Hoover, Box 111, Jamul, California.

SWAP \$25.00, A-1 COURSE IN cartooning, complete with illustrations. Want Argus or any make 35mm enlarger or Argus accessory kit. What do you have? All letters answered. Paul Glenn, R-2900 West St., Weirton, W. Va.

TRADE—HOSCH T.H.F., A.K. superhet broadcast receivers, 4 h.p. A.C. motor, 2 B eliminators, 10 Weston and Jewell meters, for S.W. superhet, typewriter, 22 rifle, candle camera, crystals or M. Hart, 152 Pennsylvania Ave., Newark, N. J.

TRADE WINTER 1937-1938 CALL Book, Speed-X high frequency buzzer and other small radio and electrical equipment for other small useful radio equipment. What do you have? W8QVZ, 251 N. Monroe Street, Hay City, Michigan.

WISH TO CORRESPOND WITH radio fans, camera enthusiasts, and coin collectors in distant lands. If you have ever heard W8QJLX, send for my QSL card! Glenn Godwin, W8QJLX, 5 Mildred Ave., Binghamton, New York.

HAVE 100 WATT TRANSMITTER, all kinds of radio parts, etc. Trade for a good metal screw cutting lathe or what have you. Also want riders manuals. Virgil Faught, Robinson, Ill.

TRADE—BRANDES PHONES, cabinet magnetic speaker, 4 s.w. coils, 2 Hammarlund midket 140 muf. condensers, audio transformer. Can use dissecting microscope. H. Halvorson, Watertown, S. D.

WILL GIVE CASH BACK NUMBER magazines or radio parts in full value for schematic diagram of electric organ formerly manufactured by Eulcon, Inc., 2 West 46 St., New York City. Ed. Sujak, 5321 West 30th Place, Cicero, Illinois.

NATIONAL SW3 WANTED, Will swap code practice osc, key, ear phone, 3 inch magnetic spkr., 1936 Radio handbook and \$5 to boot. Lee Brown, 731 S. Wayne St., Pima, Ohio.

WHAT HAVE YOU TO OFFER IN 5 meter equipment or what have you for 616 C.W. transmitter complete with crystal, meter, tube, coils, etc. Write: Fred Galla, 4331 Park Avenue, New York, N. Y.

8MM MOTORIZED MOVIE PHOTOFLECTOR (\$22) 10 reels 8 mm. film; comedy cartoon, war. Silver Screen (cost \$44) like new. Swap for view camera, stereo camera or what have you? Kotlosky, 35 Sagamore, Lynn, Mass.

TRADE ATWATER KENT RADIO chassis model 55C complete with tubes and speaker ready for operation for a small 5 tube receiver and electric phonograph or what have you? John Kreno, 5 Summit St., Swedeland, Pa.

SWAP: SET OF HAWKINS ELECTRIC Guides, U.S. Army Radio Communication, Trigonometry, other books and radio parts for radio books by Nilson and Hornung, McEwain, Henry or Ghirardi, George T. Jones, 238 North 6th, Clinton, Indiana.

I HAVE A JIG SAW, MICROSCOPE, electric razor, double barrel 12 gauge, pitcher made from macedated U.S. greenbacks, estimated \$5,000, two pairs leather jeans. Want radio books, courses, equipment. Harley Kiser, Paris, Ky.

SWAP, AC-RATED TRANSCEIVER, two 5m receivers, Philco model 50 auto radio, tubes, parts, nuke. Acra-test 9 tube special s.w. receiver, needs work, all parts o.k. For complete phone transmitter, or? Frank Dietz, 20 Highland Ave., Newark, N. J.

WANTED—FRNA, WILL SWAP pair "800" tubes, (0-25MA) West (0-100MA) Triplet, 2 pair Class "1B" transformers 46s and 53s, U.T.C. I.P.S., U.T.C. LM5, 80 M. xtal. phones. W2GWL, 7 Ave. B, N.Y.C.

WILL SWAP ULTRA STRATONS, plus 10 tube transceiver coils 2 1/2 to 5 1/2 meters for Diversity Skyriter or SX16, SX17 Hallicrafters receiver. Will pay difference if any to close deal. C. Jensen, 211 E. 200 St., Bronx, N. Y.

TRADE: RADIO PARTS, MAGAZINES, 32V "A" eliminator, camera and developing outfit, microscope, roller skates, Filmo, Hobart, sheet metal punch. Want: Telescope, binoculars, wood-metal working equipment, small gas engine, Arthur Hillier, Manito, Ill.

HAVE 50 MAGAZINES, PERFECT condition, radio parts, etc. Want small AC-DC receiver, or what have you? John Lezansky, 127-1st Avenue, New York City.

(Continued on following page)

BARTER and EXCHANGE FREE ADS (continued)

Short Wave Listening Tips

(Continued from preceding page)

HAVE WHITE RATS. POPULAR Mechanics, almost complete 1921 to 1933. Radio parts, Esquire Dry Shaver, etc. Want chemicals, Trimeter, combustion furnace or other laboratory equipment. T. C. Furnas, Jr., 1004 W. Laurel, Independence, Kansas.

TRADE - NEW SUDEE ZIPPER jacket, high collar, size 40; pair Federal phones, type 33-W, 2200 ohms, good cond. Want 2 tube S.W. receiver using 00014 mfd. V.C. (no tubes). C. Ducey, 514 N. 7th St., Phila., Pa.

TRADE UNIVEX MODEL A CAMERA, use Univex No. 00 6 exp. film. Want one of these books: "Radio-Craft" March 1938, "Radio Amateur Course" or what books have you. Alexander Podstepny, 217 Pine St., Phila., Penna.

616 TRANSMITTER, WITH COILS. Isolation insulation, also Billy high frequency crystal for manufactured short wave receiver. Peak pre-selector, or what have you? Make offer. All letters answered. Sorrin, 2806 West Salinas, San Antonio.

WILL SWAP MASTER TELEPLEX in good condition for short wave receiver. Prefer the Sky Buddy or Prezelbender. Others inquire, 3 tubes and A.C. Richard Deuel, Davenport, Neb.

WANTED. GOOD RIFLE. ANY caliber, or pair of binoculars, have radio parts, tubes, two dynamic speakers, 110 volt electric motor, transformers, call book, B. Murray, Hancock, New York.

WANT S.W.3 OR SKY BUDDY. Have 5 and 10 transmitter, Ellen H.G. 35, test equipment, meters, tubes and radio magazines, also bug. Gerald Samkowsky, 202 So. 2nd St., Brooklyn, N. Y.

SWAP ONE ROLL 35MM EASTMAN SuperX film in cartridge, 42 exp. for every 1 doz. empty 35MM cartridges. All interested in writing together a camera club, write, Walter Juranic, P.O. Box 36, Ired Hook, New York.

TRADE SEVERAL THERMO-couple RF ammeters, Post's Polypbase Duplex slide rule, Packard electro-shaver, 0-500 mil. milliammeter, several transmitting tubes, dynamic speaker or what have you. R. M. HAYLEY, WFFUN, 715 So. 2nd Ave. W., New ton, Iowa.

HAVE-COMPACT 5 TUBE BATTERY portable super-het; size 28 like; RCA portable electric phonograph. Want-recording equipment, P. P. 614 amplifier; crystals, mikes; two speed phono motor, Morton Savada, 115 Central Park West, New York City.

TWO THOUSAND BOOKS, ELECTRIC trains, toys, games, camera, projector, radiophone, stereoscope, etc. Your list for mine. M. Epstein, 2853 Rucklee, Indianapolis, Ind.

1000 DIFFERENT FOREIGN stamps to exchange stamp for stamp. Also Meissner R.F. 200 meters, 00014 coils unused, radio parts, books and magazines to exchange for stamps. Norman Basden, 1654 St. Joins Place, Brooklyn, N. Y.

HAVE SKY BUDDY WITH ADDED features as: Mactle Eye, Eye cut out switch, standby switch. Would like SW3 with power transformer and complete set coils or what have you. W4EKF, 1508 West Cass, Tampa, Florida.

SWAP SUPREME 339 ANALYZER. Burton oscillator 111 mod. 220 vac. service manuals, for receiver S.W. rifles, etc. W-3-F-L, 2910 N. Lawrence St., Phila., Pa.

TRADE SHORT WAVE RECEIVER 8 tube TRF. A.C. with plug-in coils 8 to 600 meters, also 5 tube band switch 14 to 550 meters for test equipment. State make and model number. O. Brownell, 297 DeKalb Ave., Brooklyn, N. Y.

TRADE ONE THORBARSON Amplifying transformer, one Western Union I-B, 400 ohm telegraph sounder, one sixteen inch A.K. magnetic speaker for one C.W. transmitter, Carl Hilliard, Agulita, Arizona.

S.W. LISTENER IN AUSTRALIA wants to correspond with anyone anywhere, interested in S.W. reception. All letters answered. Will forward recent back numbers local radio journals. A. C. Smith, 8 Third St., Ashbury, Sydney, N.S.W. Australia.

WE WUD LIKE TO SWAP POST card views with anyone anywhere. Are 100% on this. QRA Conrad J. Klack, 418 Perry St., Buffalo, N. Y.

WILL TRADE 189 QST MAGAZINES dating from 1921 to 1934 for short wave receiver or camera, or what have you? A. L. Bennett, No. 7 Carlyle Apts., Hibbing, Minn.

NEW ZEALAND AND AUSTRALIAN radio magazines in exchange for Cage Birds magazines, current numbers from any part of the world. J. E. Griffiths, Exchange Lane, Auckland, N.Z. Zealand.

SWAP 40 S.W.&T. MAGS., 10 Popular Mechanics and Sciences, 10 tubes, chemical, glassware, old movie projector, small microscope, books. Wanted-code machine, good receiver

or what have you? Louis Grunfelder, 529 Brook Avenue, Bronx, N.Y.C.

HAVE C MELODY BUESCHER sax. Silver. Gold bell. \$175 new. Excellent condition. Want radio, camera, short wave set, cartooning course, or what have you? No Junk, Lettoy Discor-ness, Williston, No. Dak.

WILL TRADE BRAND NEW books Applied Mathematics, Radio Manual, Practical Radio Communication by Nilson-Hornum, Surveying, Practical Electricity by Croft. For Winchester-Springfield, 30-06 with scope, Vincent D. Sullivan, Box 146, Marshfield, Vermont.

RECEIVING AND TRANSMITTING equipment including tubes, etc., complete photographic course. Will give test of bargain for flying equipment or trade everything for motorcycle, jets have your offers. Mel Parker, 1519 T Ave., La Grande, Oregon.

SWAP 37 KEY 3 ROW ITALIAN accordion, 16 basses. Made in Trieste by Guido Pioner. Genuine master. Cost \$150.00. Want 5 band all wave radio receiver, factory built. E. F. Mallory, Route 3, Peeskill, N. Y.

ONE 3A. EASTMAN KODAK IN sole leather case, also 10 reels 35MM silent films; what have you to offer in trade. Fred R. Wolcott, 273 Medford Road, Syracuse, N. Y.

ONE K&E SURVEYOR'S TRANSIT (telescope only) has 5 lenses-high power. Want S.W. receiver, other radio equipment. Joseph F. Flynn, 551 S. Longwood St., Baltimore, Md.

WILL SWAP A GOOD 5 TUBE Atwater Kent battery radio model 20. Want SW3 or SW5, Genemotor, A.C. motor or what have you? Marvin Gurlin, West Berlin, New Jersey.

WANTED. A NATIONAL SW3, A.C. and a push-pull low-power T.X.T. transmitter with power supply, Eldon Meredith, L.P.C., Port Credit, Ont., Canada.

WANTED: HAM PARTS FOR 500-750 watt CW r.f. receiver, have Supreme 851L tube and condenser tester (\$8.00 new) radio bug, phonograph, 40 watt CW r.f. WGPP, 1308-F, The Dalles, Oregon.

WILL TRADE GOOD BINOCULARS, kodak folding camera, books, magazines for Scientific fiction magazines, fan letters, fan mags., cartoons or Scientific fiction paintings. Julius Unger, 2358-64 Street, Brooklyn, N. Y.

TRADE TWELVE AVIATION magazines, fiction, fact and model building, for radio books or magazines. Value one dollar ninety cents. A. South Carolina.

HAVE 1909 LINCOLN CENTS, mandolin, Superior signal generator, new tubes, radio parts, want short wave receivers, tube tester or any testing equipment. William J. Phillips, Box 212, Gypsy, W. Va.

WILL TRADE COMPLETE Illinois School of Music ear piano play plan course (8 books) for Ghirardi's "Modern Radio Servicing" 2nd edition - or similar up-to-date book. E. W. Witte, Marion, S. Dak.

TRADE MODERN RADIO Servicing and Radio Field Service Data Books for complete set of five late issues "Mathematics for Self-Study" by E. Thompson in good condition. Urban Polkins, Breda, Iowa.

WILL TRADE ARGUS MODEL "A" camera with case; latest texts on Math. and Elect. Eng. for double barrel shot gun, sw set or? W. M. Abbott, 1345 Central Ave., Beloit, Wis.

WANT 160 METER PHONE transmitter complete, servicing instruments. Will buy or trade. State your price. Martha E. White, Pitts-ville, Maryland.

HAVE FOLLOWING BOOKS: Self Propelled Vehicles, Motor Manual, Radio Boys Mechanic, Commercial Law, Arithmetic, Freckles, Salomey James Kiss, for cheap miniature cameras \$15, for cheap microscope, 8x telescope, jig saw, chromatic harmonica, Sofus Andersen, Larkin, N.D.

WANTED: SLIGHTLY USED Teleplexes and student books in radio communications. A. F. Sokolowski, 1123rd Co. CCC, Laconia, N. H.

HAVE ABOUT 550 WORTH OF radio parts in trade for Hallcrafters Sky Buddy, Stanley Roxy, 715 Windsor Terr., Schenectady, N. Y.

WILL TRADE NEW HAMMARlund short wave 50 mfm. condenser, 2 four prong baseboard tube sockets, and 100 mfm. trimmer for a broadcast three circuit tuner. Norman L. Minks, Rt. A, Terrebonne, Oregon.

WILL TRADE WESTERN ELECTRIC D-7652 amp. 81 db. gain, rack mounting. Want 16mm sound projector or what have you? H. DRESEN, Mansfield Centre, Conn.

WANTED ONE STEWART WARNER converter (or short wave) Old converters used must be wired in perfect condition. Old converters for SW wanted. A. Emerson, 532 E. 114 St., Cleveland, Ohio.

TRADE EILEEN 5 TUBE BATTERY receiver, band spread coils new May 1938, also Fullone 2 batty. revr. for genemotor or 7 Reolure 80 meter band spread coils for National SW3, G. Pinder, VEBLB, Chaplin, Sask., Canada.

SWAP A CODE OSCILLATOR, battery charger, B supplies. Want pickup and motor or radio parts. Geo. Daubert, Maddon Ave., West Berlin, N. Jersey.

WILL GIVE 50 FOREIGN STAMPS for 15 U.S. commem. except NRA, Chicago, and Anthony. Exchange 10 tax tokens for 10 U.S. commem., 25 different postmarks for 10 U.S. commem. Orville Arnold, Box 311, Henryetta, Oklahoma.

WANTED: SHOTGUN FOR NEW 6" 11lylux magnetic speaker, good pair phones, resistors, condensers, potentiometers, tubes, 1934 Crosley superhet and mls. parts and books. Merle Hart, 4839 Hubbard, Chicago, Ill.

COMPLETE INFORMATION ON starting and operating merchants sponsored moving picture show, also pay show in halls, etc. Want used 600-21 tires, radio parts or what have you? Harry Benson, Roadshow, Chesterton, Indiana.

TRADE: 18" ANJ MAGNETIC speaker, field glasses, band-ole, 500 frequencies, 300 postmarks, Baby Browning camera, slogan buttons, 3 tube R.C. Kit, photographic equipment, two books, auto safety lighter. Make offer. R. Lewis, Griffithville, Ark.

HAVE GUITAR, KING RADIO, RCA radio, chickens, boys books, guns and other articles. Want: antennas, rifles, pens, radio, or what have you? Robt. Gallagher, 1153 W. 8th Street, Erie, Pa.

SWL EXCHANGE

SWL'S IN U.S.A. AND FOREIGN countries, let's swap SWL cards. Will QSL 100%. QRA John F. Martinik, 2400 Carson St., McKeesport, Pa., U.S.A.

OVERSEAS SWL'S SEND ME UR SWL card and a newspaper from ur location. I'll forward my QSL and a newspaper in my city. Prompt reply assured. Jack Wells, 1000-14th St., Phenix City, Alabama, U.S.A.

SWL'S OF THE WORLD, WOULD like to swap my SWL card for one of yours. I will QSL by return mail, 100%. QRA: Gerald B. Cape, P. O. Box 163, Desloge, Missouri.

SWL'S OF THE WORLD, WOULD like to swap my SWL card for one of yours. I will QSL by return mail, 100%. QRA: Forrest Lee Nelms, Desloge, Missouri.

HELLO SWL'S ANYWHERE. Let's swap SWL crds. 100% QSL hr. Vy 73 ex. DX. QRA - "The Listener in the Ranges," M. N. Wicks, Bathannah, South Australia.

SWL'S OF THE U.S.A. AND other countries: Let's swap SWL cards, all cards answered. Also want to join radio club. Homer Evans, Jr., 205 West Main, Portland, Ind., U.S.A.

SHORT-WAVE LISTENERS IN the United States or Canada. Send me one of your S.W.L. cards and I will send you one of mine promptly. Q.R.A. Horace N. Taylor, 35 Roland Road, Hlandsworth, Birmingham, England.

HI. OM'S E YL'S. WANT TO swap cards with all of you. Will send SWL card in exchange for your SWL card. QSL 100% with anybody. B. Cartmill, Market Place, Garstang, No. Preston, Lancashire, Eng.

SWL'S AND HAMS - I WISH TO correspond with you, especially foreign and eastern SW Listeners. All letters answered. Would appreciate your QSL or SWL card. QRA Rex W. Deltrick, Box 55, Clarkfork, Idaho, U.S.A.

SWL LISTENERS IN FOREIGN and U.S.A. Will exchange SWL cards. I'll QSA 100%. Joanna M. O'Brien, 565 W. 144th St., Apt. 4E, New York City, U.S.A.

WOULD LIKE TO SWAP SWL cards, postcards, and correspondence with anybody in the world. All cards and letters answered 100%. Bob Larson, 618 North Juniper Street, Los Angeles, California, U.S.A.

SEND ME YOUR SWL CARD. Will answer all Lewis Neuman, Box 8363, Pittsburgh, (18), Pa.

ATTENTION U.S. AND FOREIGN YL'S - would like to correspond and swap SWL's with any of you. QRA - Jack Hartley, 88 Diamond Bridge Ave., Hawthorne, New Jersey, U.S.A. I SWL 100%.

I WILL EXCHANGE S.W.L. cards with anyone in all parts of the world. George Poulain, 67 Mt. Pleasant St., Sydney, N.S., Canada.

WILL ANSWER ALL LETTERS and QSL's cards with picture postage card of Atlantic City. Wish to correspond with all members R.S.L. and all S.W.L. and Hams. QRA, Joseph Duffin, 8806 Atlantic Ave., Atlantic City, New Jersey.

instead of Saturdays as formerly. It is possible that later they will transmit on Fridays also, in which event notice will be given.

YV3RA, 5.88 mc., Barquisimeto, Venezuela, appears to be working at present in place of its sister station, YV3RB, 9.565 mc. Both stations operated by Señor Arturo Ramos Maggi.

YV5RR, 5.835 mc., Caracas, Venezuela, is sending out attractive new veri cards. Station relays long wave YV5RS, 1.32 mc. Address Apartado 185.

YV5RC, "Radio Caracas," has changed from 5.8 to 5.97 mc., and appears to be getting out with a better signal.

YV1RI, 6.21 mc., Coro, Venezuela, now broadcasts weekdays 6 to 10 p.m. and Sundays 10 a.m. to 2 p.m. and 6 to 7:30 p.m. or later. Station known as Radio Coro.

YV2RA, San Cristobal, Venezuela, with frequency changed from 5.755 to 5.745 mc. has less interference than before. Power 1 kw. Schedule daily, 11:19 a.m. to 12:19 p.m. and 5:49 to 9:19 p.m.

YV3RD, 6.465 mc., Barquisimeto, Venezuela, broadcasts daily 10:30 a.m. to 1:30 p.m. and 4:30 to 9:30 p.m. Address, Avda. Bella Vista No. 419.

PSH, 10.22 mc., Rio de Janeiro, Brazil, broadcasts week days from 6 to 7 p.m.; also Mondays 8 to 8:30 p.m. On Fridays the program is extended to 7:30 p.m.

PSA, 21.08 mc., carries the Italian broadcast of PSH between 12:50 and 1 p.m. on Fridays, and from 11:18 a.m. to noon on first Thursday of each month.

PSE, 14.935 mc., transmits the PSH program in German on Wednesday from 4 to 4:10 p.m., and from 4 to 4:30 p.m. on the twenty-third of each month.

CXA4, 6.125 mc., Montevideo, Uruguay, does not verify by card, but acknowledges by letter.

ZP14, Villarrica, Paraguay, which came on the air recently on 6.250 mc., advises it is now transmitting on 6.025 mc. Mondays, and Wednesdays from 2 to 5 p.m., and Saturdays and Sundays from 11 a.m. to 5 p.m. Station is called Radio Cultura and operated by Friedman Bros. Opens programs with Paraguay's march, "Campeamento Cerro Leon."

CB1180, 11.8 mc., Santiago, Chile, operated by Sociedad Nacional de Agricultura, changed on May 1st to 11.78 mc. and is now testing out near 12.0 mc. Veri cards will be forwarded for reports sent as soon as new frequency is determined. No I.R.C. necessary. Address, Casilla 40-D.

CB1185, 11.85 mc., Santiago, Chile, operated by Señor Jorge Echegoyen, is reported on the air with 2 1/2 kw. power.

CB946, 9.46 mc., will soon go on the air at Santiago, Chile. Station to be known as Radio Basquedano and operated by Markoff Bros. Ltd. Power 500 watts.

CB1174, 11.74 mc., Santiago, Chile, is another Chilean station said to be broadcasting with 1 kw. power. Operated by Orlandini and Taggio, Ltd.

LRA, 9.69 mc., Buenos Aires, Argentina, broadcasts Mondays to Thursdays, 10:30 a.m. to 1 p.m. and 6 to 9 p.m. On Fridays it begins at 4 p.m. on evening transmission; Saturday and Sunday evenings from 7 to 9 p.m.; closes Sunday morning program at noon. Station known as Radio Del Estado and works with 10 kw. power.

MEXICO

XEXA, 6.133 mc., Mexico City, broadcasts week days 8-11 a.m., 2:30 to 4 p.m., 7:30 p.m. to 12:45 a.m. Sundays, 7:30 p.m. to 12:45 a.m.

XECR, 7.38 mc., Mexico City, is on the air from 7 to 8 p.m. only.

XEWI, 11.9 mc., Mexico City, has recently increased its power to 400 watts and is getting out better. This station also has an assigned frequency of 6.015 mc. which is used at times.

XETA, 11.76 mc., Monterrey, Mexico, states they relay the programs of NET, with 500 watts power, daily from 1 to 3:30 p.m. They have, however, been reported as being heard on one or two occasions in late evening.

XEGW, 6.11 mc., Mexico City, relays XEJW. Call was changed from XEPV some time ago.

CUBA

COCQ, 9.74 mc., Havana, Cuba, dropped down to 9.71 mc. to avoid interference from CSW, Lisbon. COCQ has increased power to 5 kw.

COCO, 6.01 mc., Havana, Cuba, now using 2 kw. power on short waves and transmitting from 8 a.m. to 11:30 p.m. daily.

COKG, Santiago, Cuba, although assigned to 6.2 mc., is testing on 8.935 mc. with the permission of Cuban authorities. Veri cards showing frequency as 6.2 mc. are sent, however, for reports on last named frequency. Address, Apartado 137.

COCW, 6.33 mc., Havana, Cuba, "The Voice of Antilles," is at last sending veri cards in answer to reports.

COCM, 9.833 mc., Havana, Cuba, relays CMCN from 8 a.m. to 1 a.m. daily. Theme song "One B.C. March" at opening and closing. No I.R.C. required but postage stamps appreciated.

COCX, Havana, Cuba, still on 11.74 mc., regardless of assignment of 11.65 mc.

COHB, 6.28 mc., Sancti-Spiritus, Cuba (deleted from service).

WEST INDIES

Radio Martinique, 9.7 mc., Fort-de-France, F.W.I., no call is assigned. Veri card very attractive in many colors. Power 200 watts.

PJCI, Willemstadt, Curacao, sends a new veri card, but shows the freq. as 9.091 mc. (changed from 5.929). This station was listed on 5.929 and 9.473 mc.

HH2S, Port-au-Prince, Haiti, has moved from 5.91 to 5.95 or 5.96 mc. and apparently improved the facilities and increased the power, judging from the signal produced. Signs off with National Anthem and "Taps" on chimes. English period 9:15 to 9:35 p.m.

HIG, Ciudad Trujillo, Dom. Rep., in a late letter states station is on 6.28 mc. and 9.3 mc. with 150 and 200 watts power, respectively. Evening schedule of both frequencies has been extended one hour, to 9:40 p.m. National Anthem at opening and closing. At present out of veri cards, but new supply ordered. Veri cards sent direct to all making correct reports.

HI5P, 6.565 mc., Puerto Plata, HI6H, 6.6 mc., Ciudad Trujillo, and HI5G, 6.66 mc., La Vega, Dominican Republic, are late stations broadcasting regularly. Verifications are being received.

HI4V, 6.45 mc., San Francisco de Macoris, Dom. Rep., has changed schedule to 6:10 to 10:10 p.m. daily except Sunday.

HI5E, 9.55 mc., Ciudad Trujillo, Dom. Rep., is on the air with but 10 watts power. Apparently not heard, as this frequency is occupied by W2XAD and XEFT.

HI3X, 17.4 mc., Ciudad Trujillo, Dom. Rep., is new frequency added. HIX, long wave, 800 kc., now has relays by HI1X, 6.34 mc., HI2X, 11.96 mc. and HI3X, 15.28 and 17.4 mc. HI1X and HI2X work on regular assigned programs. HI3X frequen-

(Continued on following page)

FREE CATALOGS and INFORMATION

By carefully reading the advertising columns, you will find many offers to furnish literature containing valuable technical information that will help you in your work. Use this list freely.

Firm	Business	Offer	No.	Cost	Adv. Page
Allied Radio Corp.	Mail Order	1939 Catalog		Free	421
American Microphone Co.	Parts Mfr.	Catalog	29	Free	435
Amperite Co.	Parts Mfr.	Illustrated Bulletins		Free	426
Astatic Microphone Lab.	Parts Mfr.	Catalog	11	Free	433
Bliley Electric Co.	Parts Mfr.	Engineering Bulletin Circular	E-6 A-6	10c Free	427
Browning Laboratories	Kit & Parts Mfr.	Brochure.. Browning 83 Bulletin.. BL-5 Tuners		Free	425
Brush Development Co.	Parts Mfr.	Catalog		Free	421
Bud Radio, Inc.	Parts Mfr.	Catalog Station Log & Data Ek.	139	Free 10c	424
Burstein-Applebee Co.	Mail Order	Catalog		Free	435
Candler System Co.	Code Course	Book of Facts		Free	430
Clough-Brengle Co.	Test Equipment	Catalog		Free	427
Cornell-Dubilier Elec. Corp.	Parts Mfr.	Catalog	161	Free	435
Coyne Electrical School	Trade School	House Organ Electrical Catalog Radio Catalog		Free	387
Dodge's Institute	Radio School	Catalog		Free	430
Gold Shield Products	Mail Order	Catalog		Free	426
Hammarlund Mfg. Co.	Set & Parts Mfr.	1939 Catalog		Free	433
Henry Radio Shop	Dealer	List		Free	426
Instructograph Company	Code Machine	Information		Free	430
International Correspondence Schools	Corres. School	Booklet		Free	448
International Resistance Co.	Parts Mfr.	Folder		Free	437
Korrol Radio Products Co.	Parts Mfr.	Folder		Free	433
Kusterman, Oscar B.	Set & Kit Mfr.	Catalog Circular	D39	10c 3c	428
Mass. Radio School	Radio School	52-page Catalog		Free	431
Midwest Radio Corp.	Set Mfr.	1939 Catalog		Free	B. C.
Million Radio & Tel. Labs.	Test Equipment	Circular		Free	433
Modell's	Mail Order	1938 Giant Catalog		Free	424
National Company, Inc.	Set & Parts Mfr.	Catalog		Free	I.B.C.
National Radio Institute	Radio School	64-page Book		Free	385
National Schools	Radio Schools	Radio & Television Eklt.		Free	430
New York YMCA Schools	Trade School	Booklet		Free	431
Par-Metal Products Corp.	Parts Mfr.	Catalog	39	Free	421
Premax Products	Parts Mfr.	Bulletins		Free	427
Radio & Technical Publ. Co.	Radio Textbooks	Circulars on each Book		Free	431
Radio Training Assn. of America	Radio School	Book		Free	430
Ralston Record Company	Code Course	Information		Free	431
RCA Institutes, Inc.	Radio School	Catalog		Free	431
Royal Typewriter Co.	Typewriter Mfr.	Information		Free	448
Sargent, E. M., Co.	Set Mfr.	Data		Free	427
Scientific Diathermy Corp.	S. W. Therapy	32-page Book 24-page Book		Free	437
Solar Mfg. Corp.	Parts Mfr.	General Parts Catalog Transmitting Catalog Condenser Testers Cat.	9S 2X CBCC-1	Free	428
Sprague Products Co.	Parts Mfr.	Catalog		Free	427
Sprayberry Academy of Radio	Radio School	44-page Book		Free	423
Telex Co.	Code Machine	Booklet	S11	Free	431
Terminal Radio Corp.	Dealer	Monthly Bulletin		Free	424
Triplett Electrical Inst. Co.	Parts Mfr.	Catalog		Free	439
Van Nostrand, D., Co.	Technical Books	Catalog		Free	419
Wholesale Radio Service Co.	Mail Order	1939 Radio Catalog Camera Catalog		Free	417 429

**OWN A ROYAL
PORTABLE ON
YOUR OWN
TERMS**

**FREE
HOME
TRIAL**



**ONLY
A FEW
CENTS A
DAY**

ACT NOW!
You needn't risk a penny!

Royal's generous free HOME TRIAL will prove to your satisfaction that a genuine, latest model, factory-new Royal Portable is the typewriter for you—simple to use, convenient, built to give a life-time of service! Includes such office typewriter features as full-size keyboard, Royal's famous Touch Control, Finger Comfort Keys, and many others. Terms to suit your purse—cash for only a few cents a day. Mail the coupon today for full information. No obligation.



ACT NOW! TODAY!

ROYAL TYPEWRITER CO., INC.
Dept. B-521, 2 Park Avenue
New York, N. Y.

Tell me how I can own—for only a few cents a day—a latest model Royal Portable—with Carrying Case and Instant Typing Chart FREE.

Name _____
Street _____
City _____ State _____

I already own a _____ Typewriter, Serial No. _____ Tell me how much you will allow on it as CASH payment on a new Royal.



**FOR THE
RADIO SERVICE MAN,
DEALER AND OWNER**

The man who enrolls for an I. C. S. Radio Course learns radio thoroughly, completely, practically. When he earns his diploma, he will KNOW radio. We are not content merely to teach the principles of radio, we want to show our students how to apply that training in practical, every-day, radio service work. We train them to be successful!

INTERNATIONAL CORRESPONDENCE SCHOOLS

Box 2882-E, Scranton, Penna.

Explain fully about your course in the subject marked X:

RADIO
 EXPERIMENTAL TELEVISION
 SOUND TECHNICIANS
 AVIATION SECTION OF RADIO OPERATING

Name _____ Age _____
Address _____

Short Wave Listening Tips

(Continued from preceding page)

cies are used on occasional broadcasts of special events.

H13C, La Romana, Dom. Rep., insists it is on 6.73 mc., but Director of Communications says on 6.105 mc. Hours given as 8:30 and 11:30 a.m.

H11L, Santiago de los Caballeros, Dom. Rep., advises that frequency of station is 6.48 mc.; on the air 9:40 to 11:40 a.m. and 7:40 to 9:40 p.m. Open and close with National Anthem. Signal—3 notes on xylophone. Address P.O. Box 356.

CENTRAL AMERICA

TGS, 5.713 mc., Guatemala City, Guatemala, which was off the air for a spell, has completed its testing and is now regularly assigned and in service on 5.790 and 11.58 mc. Reports should be sent to Radiodifusora TGS, Casa Presidencial, Señor Julio Meza Caballeros, Director General.

TGWB, Guatemala City, Guatemala, the new station which was to go on the 49 meter band, has been heard on about 6.52 mc. TGWB will relay programs of TGW also.

TG2X, 5.94 mc., Guatemala City, Guatemala, is said to have gone off the air. Reliable source states freq. to be vacated soon.

TG2, Guatemala City, Guatemala, advises that its frequency is now fixed at 6.190 mc., where it is heard daily. Power 300 watts. Reports should be sent to Director General of Electrical Communications.

TGQA, Quezaltenango, Guatemala, is still on 6.4 mc. Reports should be forwarded to address of TG2.

TI2RS, 7.45 mc., San Jose, Costa Rica, on the air daily except Sunday from 9:30 to 11 p.m. Señor Rogelio Sotela, Proprietor, who states station is called Radioemisora "Athena."

TI8WS, 7.55 mc., Puntarenas, Costa Rica, is reported heard on 6.37 mc.

TI2XD, 11.92 mc., San Jose, relays the programs of TIND, San Jose.

Station operated by Señor Carlos Eduardo Rodriguez, Gerente, who advises station is on the air with 600 watts power; opening theme, March, "Don Quixote"; closing, Rhumba, "El Manicero"; Schedule, 11 a.m. to 2 p.m. and 5 to 11 p.m., except Sunday. Address, Apartado 1729. Station known as "La Voz del Pilot." John G. Daly is proprietor. Veri cards are being received.

TIEM, 10.05 mc., San Jose, is the last station to come on the air in Costa Rica.

Schedule is 11 a.m. to 11 p.m. week days and 10 a.m. to 6 p.m. on Sundays. Veri card received by writer shows station is called Radio "El Mundo"; long wave 1400 kc. and short wave as above, 1 kw. power. Address Apartado 1049.

Advice from the station is that it has transferred to 6.130 mc.

HP5G, Panama City, has moved from 11.78 to 11.895 mc.

Programs open and close with prelude to "Traviata." Station on air regularly from 9:30 a.m. to 1 p.m. and 6 to 11 p.m. Also on with specials at various hours. Veri cards in blue and white.

HP5I, Aguadulce, Panama, is probably off the air as it is not listed by Panama authorities.

HP5H, 6.122 mc., Panama City, plays record "Whistler and His Dog" at closing.

HP5B, 6.03 mc., Panama City, Panama, now has schedule 9:30 a.m. to 1 p.m. and 5 to 10 p.m. daily.

YNGU, 9.3 mc., Managua, Nicaragua, is off the air at present. New station and transmitter to be installed later but probably not on the above frequency.

YNLG, 6.61 mc., Managua, Nicaragua, with 1 kw. power, broadcasts from 1 to 3 p.m. and 7 to 11 p.m. Station known as "Ruben Dario."

ZIK2, 10.6 mc., Belize, British Honduras, broadcasts Tuesdays, Thursdays and Saturdays 1:30 to 2 p.m. and 8:30 to 9 p.m.

Index to Advertisers

A	
American Radio Corporation	421
American Microphone Co.	435
Amperite Co.	426
Astatic Microphone Laboratory, Inc.	433
B	
Barter & Exchange Free Ads	444, 445, 446
Bliley Electric Co.	427
Browning Labs., Inc.	425
Brush Development Co., The	421
Bud Radio, Inc.	424
Burstein-Applebee Co.	435
C	
Candler System Co.	430
Chemical Rubber Publ. Co.	435
Cough-Brengle Company	427
Commercial Notices	444
Cornell-Dubilier Electric Corp.	435
Coyne Electrical School	387
D	
Dataprint Company	428, 441
Dodge's Institute	430
F	
For Sale Ads	444
G	
Gold Shield Products	426
H	
Hammarlund Manufacturing Co., Inc.	433
Henry Radio Shop	426
Hudson Specialties Company	434
I	
Instructograph Company	430
International Correspondence Schools	448
International Resistance Company	437
K	
Korrol Radio Products Co.	433
Kusterman, Oscar B.	428
M	
Mass. Radio School	431
Midwest Radio Corporation	Back Cover
Million Radio & Television Laboratories	433
Modell's	424
N	
National Company, Inc.	Inside Back Cover
National Plans Institute	439
National Radio Institute	385
National Schools	430
New York YMCA Schools	431
P	
Par-Metal Products Corp.	421
Premax Products	427
R	
Radio Amateur Course	Inside Front Cover
Radio & Electronic Dictionary	443
Radio & Technical Publ. Co.	431
Radio-Craft	437
Radio Publications	432, 438, 443
Radio Training Assn. of America	430
Ralston Record Company	431
RCA Institutes, Inc.	431
Royal Typewriter Co., Inc.	448
S	
Safair Flying School	441
Sargent, E. M., Co.	427
Scientific Diathermy Corp.	437
Short Wave League	442
Solar Mfg. Corp.	428
Sprague Products Co.	427
Sprayberry Academy of Radio	423
T	
Technifax	441
Teleplex Co.	431
Terminal Radio Corporation	424
Triplett Electrical Instrument Co.	439
V	
Van Nostrand, D., Co.	419
W	
Wellworth Trading Company	432, 443
Wholesale Radio Service Co., Inc.	417, 429

(While every precaution is taken to insure accuracy, we cannot guarantee against the possibility of an occasional change or omission in the preparation of this index.)

NC-100 XA

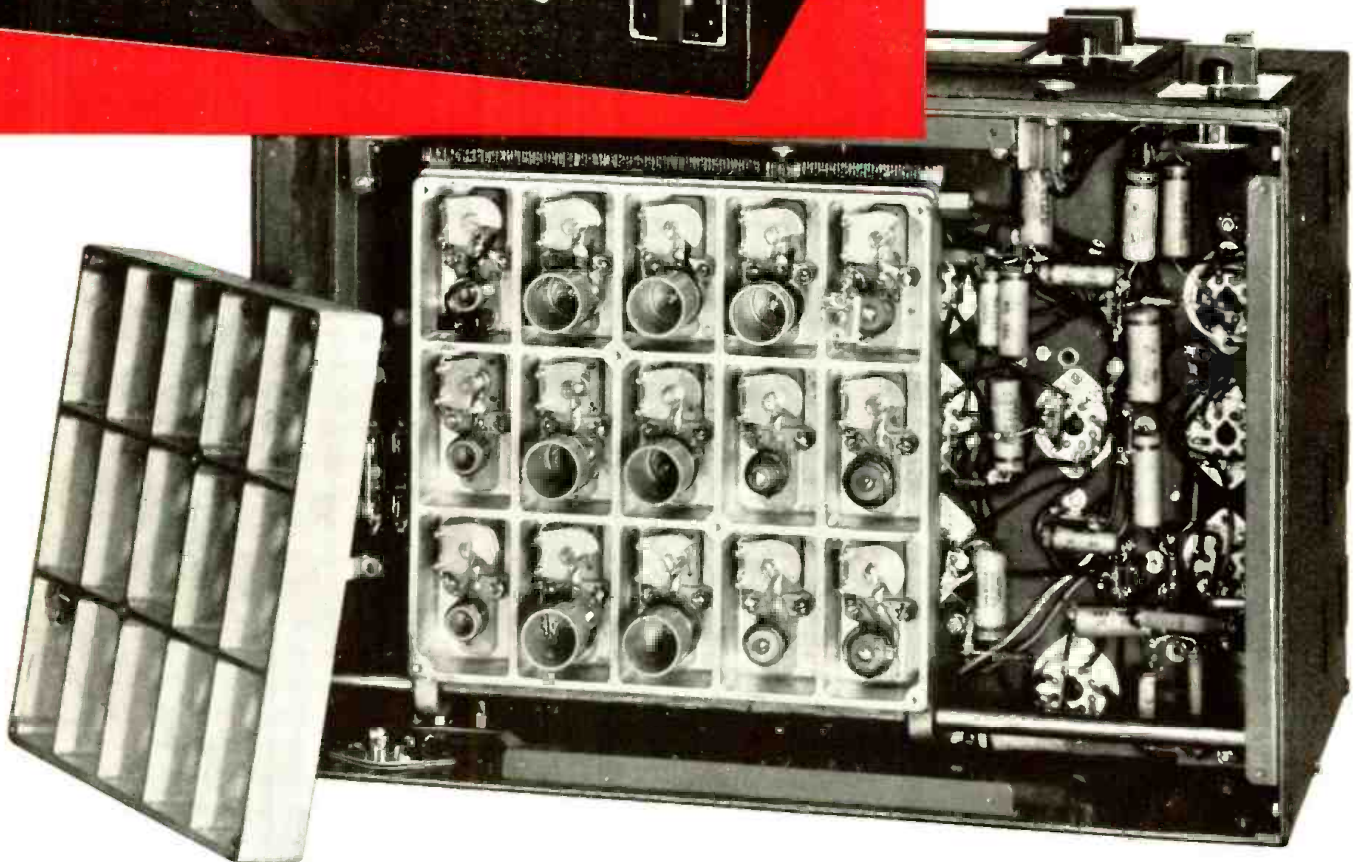
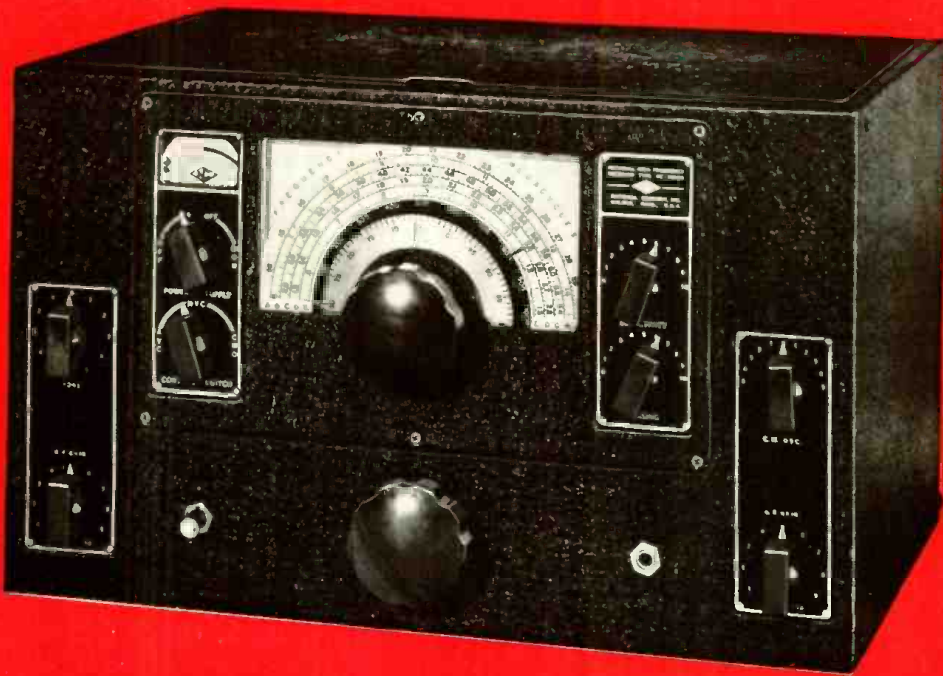

QUALITY THROUGHOUT

Look at the HF coils in the NC-100XA above. Each in its own separate compartment in the heavy cast aluminum shield. Each of low-loss construction, painstakingly wound and carefully matched. Each trimmed by an air-dielectric condenser. And each with the shortest possible leads, for the entire coil assembly moves on a track, bringing the desired coil range into position directly below the main tuning condenser. Such construction is expensive, but it is typical of the quality that extends to every detail . . . National builds to a quality standard, for men who judge receivers on performance.

**NATIONAL
COMPANY**
MALDEN • MASS.



Oct 23

SENSATIONAL MIDWEST FACTORY-TO-YOU SALE

MODERNIZE YOUR OLD RADIO... PUT THIS NEW CHASSIS IN YOUR PRESENT CABINET!

NEW 15-TUBE

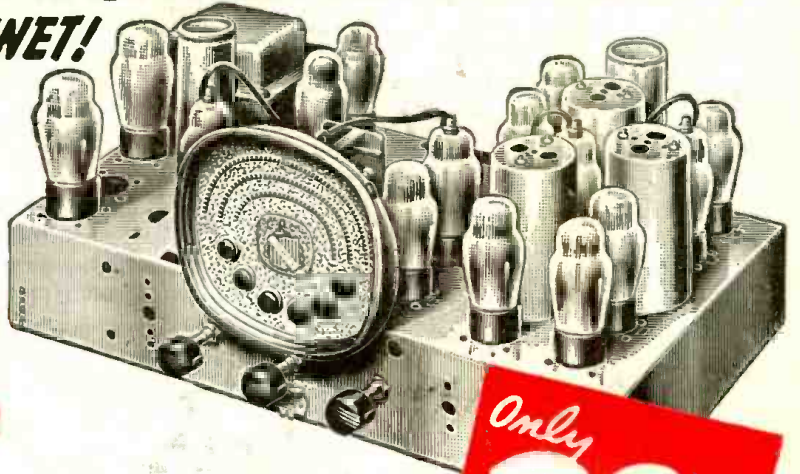

WORLD-WIDE RADIO

SAVE UP TO 50% DIRECT FROM MIDWEST FACTORY

Only **\$29.95**
WITH TUBES AND SPEAKER



ONCE again, Midwest scoops the radio world with the year's greatest radio value! Here it is! A big, powerful, new 15-tube, world-wide, Midwest. At its sensational factory-to-you price of \$29.95, this new 1939 radio is one of the biggest bargains in Midwest's nineteen years of pioneering! Why be content with an 8 or 10-tube set . . . when it is so easy to install this big, powerful 15-tube chassis (in your present cabinet) for the same price! For a little more than the cost of new tubes, you can modernize your old radio and get exciting world-wide, all-wave reception. Only a limited number of these 15-tube chassis are offered during this short-time sale. So, you will have to act fast if you want to secure one of these sensational bargains. First come . . . first served!

While the \$29.95 15-tube Midwest chassis is a truly sensational bargain, the Super DeLuxe 5-Band 17-Tube Midwest console model, shown here, is one of many of Midwest's even bigger values. It enables you to enjoy foreign reception at its best—it presents stirring foreign events to you hours before your local papers come out with their "extras." It will delight you with its tremendous 12,000-mile range on 5 bands, brilliant overseas reception and glorious new tone.

**AMAZING
NEW
EASY-PAY
PLAN**

**30 DAYS
FREE
TRIAL**



Send for the new free 1939 catalog and feast your eyes on its history-making values. It pictures many 1939 models to suit every purse. The famous Midwest 30 days FREE TRIAL Plan gives you 30 days to make up your mind. In addition, you can secure \$30.00 trade-in allowance (on some Midwest radios). Easy payments. Money Back guarantee.

**SEND FOR FREE 1939
FACTORY CATALOG**

MIDWEST *Factory-to-You* RADIOS

DEPT. 14-FF MIDWEST RADIO CORPORATION...CINCINNATI, OHIO, U.S.A.
Manufacturers of Quality Radios Since 1920

PASTE COUPON ON 1¢ POSTCARD... OR

Write Today!

MIDWEST RADIO CORPORATION
Dept. 14-FF Cincinnati, Ohio

Send me your new FREE catalog, complete details of your liberal 30-day FREE Trial Offer, factory-to-you wholesale prices, and big TRADE-IN Offer.

Name..... (PLEASE PRINT CLEARLY)

Address.....

Town..... State.....

User-Agents Make Easy Extra Money.
Check Here for details